



*Owner's Engineer Services for the Comox No. 2 Pump  
Station Project*

# **Indicative Design Report**





*Owner's Engineer Services for the Comox No. 2 Pump Station Project*

---

# Indicative Design Report

Prepared By

.....  
Negin Tousi, EIT  
Assistant Project Engineer

North Vancouver Opus Office  
210-889 Harbourside Drive  
North Vancouver BC V7P 3S1  
Canada

Reviewed By

.....  
Walt Bayless, P.Eng.  
Deputy Project Manager

Telephone: +1 604 990 4800  
Facsimile: +1 604 990 4805

.....  
Roger Warren, P.Eng.  
Project Manager

Date: June 12, 2017  
Reference: D-13125.00  
Status: Draft 1

This document has been prepared by Opus International Consultants (Canada) Ltd (“Opus”) for the exclusive use and benefit of the client to whom it is addressed. The information and data contained herein represent Opus’ best professional judgement in light of the knowledge and information available to Opus at the time of preparation and using skills consistent with those exercised by members of the engineering profession currently practicing under similar conditions. Except as required by law, this document and the information and data contained herein are to be treated as confidential and may be used and relied upon only by the client. Opus denies any liability whatsoever to other parties who may obtain access to this document for any injury, loss or damage suffered by such parties arising from their use of, or reliance upon, this document or any of its contents without the express written consent of Opus and the client. Information in this document is to be considered the intellectual property of Opus in accordance with Canadian Copyright Law.

# Contents

<b>Project Background</b> .....	<b>1</b>
<b>1 Project Overview</b> .....	<b>1</b>
<b>2 Key Design Criteria</b> .....	<b>1</b>
2.1 Design Capacity .....	1
2.2 Service Life.....	3
<b>3 Site Conditions</b> .....	<b>3</b>
3.1 Archaeological .....	3
3.2 Environmental (Report to come) .....	6
3.3 Geotechnical (Report to come).....	7
<b>Indicative Design</b> .....	<b>9</b>
<b>4 Conveyance</b> .....	<b>9</b>
4.1 Design Criteria.....	9
4.2 Forcemain Tie-In and Beech Street Alignment.....	9
4.3 Alignment to the CVWPCC – Curtis Road.....	12
<b>5 Architectural – Pump Station</b> .....	<b>13</b>
5.1 Design Criteria.....	13
5.2 General Arrangement.....	13
5.3 Zoning Requirements.....	14
<b>6 Civil</b> .....	<b>15</b>
6.1 Design Criteria.....	15
<b>7 Structural</b> .....	<b>16</b>
7.1 Design Criteria.....	16
7.2 Land Features .....	17
<b>8 Process Mechanical</b> .....	<b>17</b>
8.1 Design Criteria.....	17
8.2 Wet Well and Dry Well .....	18
<b>9 Building Mechanical</b> .....	<b>20</b>
9.1 Heating and Ventilation Requirements .....	20
9.2 Pump Station Area Classification and Air Changes .....	20
<b>10 Odour Control</b> .....	<b>21</b>
10.1 Design Criteria.....	21
10.2 Primary – Activated Carbon Scrubber.....	21
10.3 Secondary – Biofilter .....	21
<b>11 Noise and Vibration</b> .....	<b>21</b>
11.1 Baseline Noise Monitoring .....	21
11.2 Resultant Design Criteria .....	22
11.3 Noise Mitigation .....	22
<b>12 Electrical, Instrumentation, and Controls</b> .....	<b>23</b>
12.1 Design Criteria.....	23
12.2 Electrical Power Supply .....	23
12.3 Estimated Site Maximum Demand.....	24

12.4	Motor Control Centre.....	24
12.5	Back-Up Generator .....	26
12.6	Electrical Appurtenances .....	26
12.7	Instrumentation & Controls .....	27
12.8	Communication Systems .....	28
<b>13</b>	<b>Permit and Approvals.....</b>	<b>29</b>
<b>14</b>	<b>Utility Coordination .....</b>	<b>30</b>
14.1	Request for Information .....	30
	<b>Cost Estimate .....</b>	<b>31</b>

**APPENDICES**

- A – Archaeological Report
- B – Environmental Report (To come)
- C – Geotechnical Investigation Report (To come)
- D – Sample General Arrangement and Process Drawings (Draft)
- E – Topographic Survey of Pump Station Property (To come)
- F – Topographic Survey of Pipe Alignment (To come)
- G – BC One Call Submittal Responses
- H – Detailed Cost Estimate

**List of Figures**

Figure 3-1:	Location of Comox and Comox Harbour Sites (Source: Baseline Archaeological) .....	5
Figure 3-2:	Geotech Test Hole Locations (Source: Google Earth) .....	7
Figure 4-1:	Beech Street Tie-In and Alignment (Source: Google Earth).....	9
Figure 4-2:	Hot Tapping Process (Source: Pacific Flow Control).....	11
Figure 4-3:	Final Configuration (Source: Pacific Flow Control).....	12
Figure 4-1:	Curtis Road Alignment (Source: Google Earth) .....	13
Figure 5-2:	Typical Setbacks .....	14
Figure 8-1:	System Curves.....	18
Figure 11-1:	Measurement Positions.....	22
Figure 13-1:	MOTI Roads in the Work Area.....	29

**List of Tables**

Table 2-1:	Assumed growth rates.....	1
Table 2-2:	Design population projections .....	2
Table 2-3:	Design flow projection Assumptions .....	2
Table 2-4:	Design flow projections .....	2
Table 2-5:	Service Life of Major Components.....	3
Table 3-1:	Geotechnical Test Holes.....	8
Table 5-1:	Height and Setback Requirements.....	14
Table 9-1:	Heating and Ventilation.....	20
Table 9-2:	Room Classifications .....	20
Table 11-1:	Noise Baseline .....	22



Table 12-1: Design Parameters..... 23  
Table 12-2: Estimated Site Maximum Demand..... 24  
Table 12-3: Equipment Dimension..... 26

# Project Background

## 1 Project Overview

The Comox Valley Regional District (CVRD) operates and maintains the Courtenay-Comox trunk sewer system that discharges at the Comox Valley Water Pollution Control Centre (CVWPCC). The Courtenay pump station (Courtenay PS) and the Jane Place pump station (Jane PS) are the two main pump stations along this trunk sewer. The forcemain for the sewer system runs along the foreshore of the Comox Harbour, past Goose Spit, and along the Willemar Bluffs to the CVWPCC. Due to tide action, erosion has presented a risk to the integrity of the forcemain along the Bluffs. This, paired with future capacity limitations, prompted the CVRD to initiate studies to assess realignment options.

Studies conducted throughout the years recommended that a new pump station be built that would serve as a booster station to allow for the rerouting of the Willemar Bluffs section of the forcemain overland to the CVWPCC. The proposed Comox No. 2 pump station (No. 2 PS) and new conveyance piping will allow the CVRD to increase the trunk sewer system capacity. The proposed location for the Comox No. 2 pump station is 98 Beech Street in Electoral Area 'B'.

The CVRD has selected a design-build (DB) procurement to accelerate the design and construction schedule for the Comox No. 2 pump station project to allow DB teams to develop innovative solutions for the various key aspects of the project. The general design requirements for this project are laid out in the Indicative Design section below.

## 2 Key Design Criteria

### 2.1 Design Capacity

Following review of the previous studies completed on this sewage system and their respective assumptions, as well as the most current census data, the following design populations and flows projections were produced.

#### 2.1.1 Design Population

The design population is projected from 2016 through 2068. It accounts for the most current census data (2016) and applies the McElhanney 2011 growth rate structure moving forward from this year. This structure, applied over the 52-year timeline, yields an annual growth of 1.72%. Table 4 shows the design population projection.

**Table 2-1: Assumed growth rates**

Growth 2008-2018	4.0%	4.0%
Growth 2019-2028	3.0%	3.0%
Growth 2029-2038	2.0%	2.0%
Growth 2039-2058	1.0%	1.0%

**Table 2-2: Design population projections**

Year	Courtenay	Comox	Total
2006 (a)	22,021	12,385	34,406
2011 (a)	24,099	13,627	37,726
2016 (b)	25,599	14,028	39,627
2018	27,688	15,173	42,861
2028	37,210	20,391	57,601
2038	45,359	24,856	70,215
2048	50,105	27,457	77,561
2058	55,347	30,329	85,676
2068	61,137	33,503	94,640

(a) CVRD website

(b) Canadian census website

\*Growth rate per MCSL Master Plan section 4. Based on 'most probable projections as defined by City staff. Growth from 2008 - 2016 not included as actual data is provided.

No growth projection from 2058 - 2068 in MCSL report. Assumed 1%.

## 2.1.2 Design Flows

### Projected Flows

Pump station flow data was provided by the CVRD for both pump stations. The data consisted of daily totalized flow for the 2016 year and totalized flow per minute for the December 2016. Flow data was evaluated and compared to the population to determine a per capita daily flow. Average per capita daily flow for Courtenay and Comox were found to be 390 L/capita/day and 315 L/capita/day, respectively. This value is inclusive of I&I.

Due to the fact that McElhanny's 2011 *CVRD Sanitary Sewer Master Plan* provides the most relevant design value recommendations and the design population is based on McElhanny annual growth rates, the design flow is based on the McElhanny design recommendations. Tables 2-3 and 2-4 provides the design flows.

**Table 2-3: Design flow projection Assumptions**

Per Capita Flow [L/d/c]*	240	240
I/I [L/s/ha]*	0.17	0.17
Area [ha]*	1,950	650

**Table 2-4: Design flow projections**

Year	Courtenay		Comox		Total
	PF (a)	Flow [L/s]	PF (a)	Flow [L/s]	Flow [L/s]
2016	2.2	489	2.4	203	691
2028	2.2	500	2.3	209	709
2038	2.1	551	2.3	239	790
2048	2.1	593	2.2	264	857
2058	2.1	617	2.2	278	895
2068	2.0	644	2.2	293	937

\* based on MSCL Master Plan recommended design criteria (Table 11)

(a) Peaking factor from MMCD  $PF=6.75P^{-0.11}$

## Design Flows

The 2068 projected flows are estimated at 937 L/s. However, the CVRD intends to maximize the lifetime use of the No. 2 PS. Therefore, the No. 2 PS is to be designed to meet 1,000 L/s at commissioning with the capability to be expanded to meet 1,500 L/s flows in the future. Provisions for additional equipment's and instrumentation are to be incorporated into the design.

## 2.2 Service Life

The design service life of the major components of the project are as follows:

**Table 2-5: Service Life of Major Components**

Component	Lifetime (yrs)
Pump Station	
Building	50
Instrumentation	20
Piping	20
Valves	20
Pumps	20
Forcemain	
Piping	20
Valves	20

## 3 Site Conditions

Archaeological, environmental, and geotechnical site conditions are summarized below. The respective reports can be found in the appendices.

### 3.1 Archaeological

The Baseline Archaeological Services Ltd. (Baseline) report in 2015 studied the *Proposed South Sewer Project Royston to Cape Lazo Outflow Segment*. The area studied encompasses the work area for the No. 2 PS project. The complete environmental assessment is attached as Appendix A. Below are the applicable findings and recommendations.

#### 3.1.1 Comox Harbour - DkSf-44

The archaeological site encompasses much of the intertidal area enclosed by Goose Spit. The site is delineated by the shoreline and primarily intertidal area as opposed to the specific archaeological features which are present within the site. The site was divided into two separate polygons to remove a subtidal area at the HMCS Quadra dock. The features include the remains of wooden weir stakes which were used to create numerous fish trap complexes within the area (Figure 3-1).

A SAP will be required for development within the archaeological site boundary. If weir stakes are to be impacted, a mitigative plan will be developed in consultation with the BC Archaeology Branch. This may involve the radiocarbon dating of impacted weir stakes and appropriate storage of the features.

### 3.1.2 Comox - DkSf-4

The archaeological site is located along the shoreline running from the Comox Marina to Goose Spit (Figure 3-1). The site is a shell midden from which artifacts, faunal remains and human remains have been recovered. At the base of Croteau Road, the site is recorded as being approximately 40 m in width.

The development area was subject to an AIA in 1993 (Permit 1993-0038) when the property between Croteau Road and Mack Laing Nature Park was being considered for a housing development (Brolly, 1993) and prior to its establishment as MacDonald Wood Park. The assessment noted the historic disturbances through the area but found a significant portion of the site remains intact, with the largest deposits being in closer proximity to Brooklyn Creek and becoming smaller to the east at Croteau Road. The intact deposits are primarily located on the edge of a raised beach terrace, with the midden deposits at the base of Croteau Road being assessed as having a low significance.

The previous developments (CVWPCC sewer system and Croteau Road) within the vicinity of the proposed pump station, effluent line and sewer main have caused significant disturbances to portions of the archaeological material, with the potential for intact archaeological remains being present on the raised beach terrace. The proposed developments can be managed under a SAP with a condition of archaeological monitoring as well as a testing methodology in advance of the construction for potentially intact deposits.

### 3.1.3 Croteau – Lazo

The field visit included vehicular and pedestrian traverses of Croteau, Lazo, Brent and Curtis Roads. Brent and Lazo Road area were considered to have a low potential for archaeological remains due to their inland locations. The majority of Croteau Road was also considered to have a low potential for archaeological remains. At the time of the field visit, excavations around an existing manhole was occurring at the junction of Croteau and Midden Road. The excavation revealed sterile silts and clay.

Based on the absence of previously recorded archaeological remains and the assessed low archaeological potential, no further archaeological work is recommended for this portion of the project.

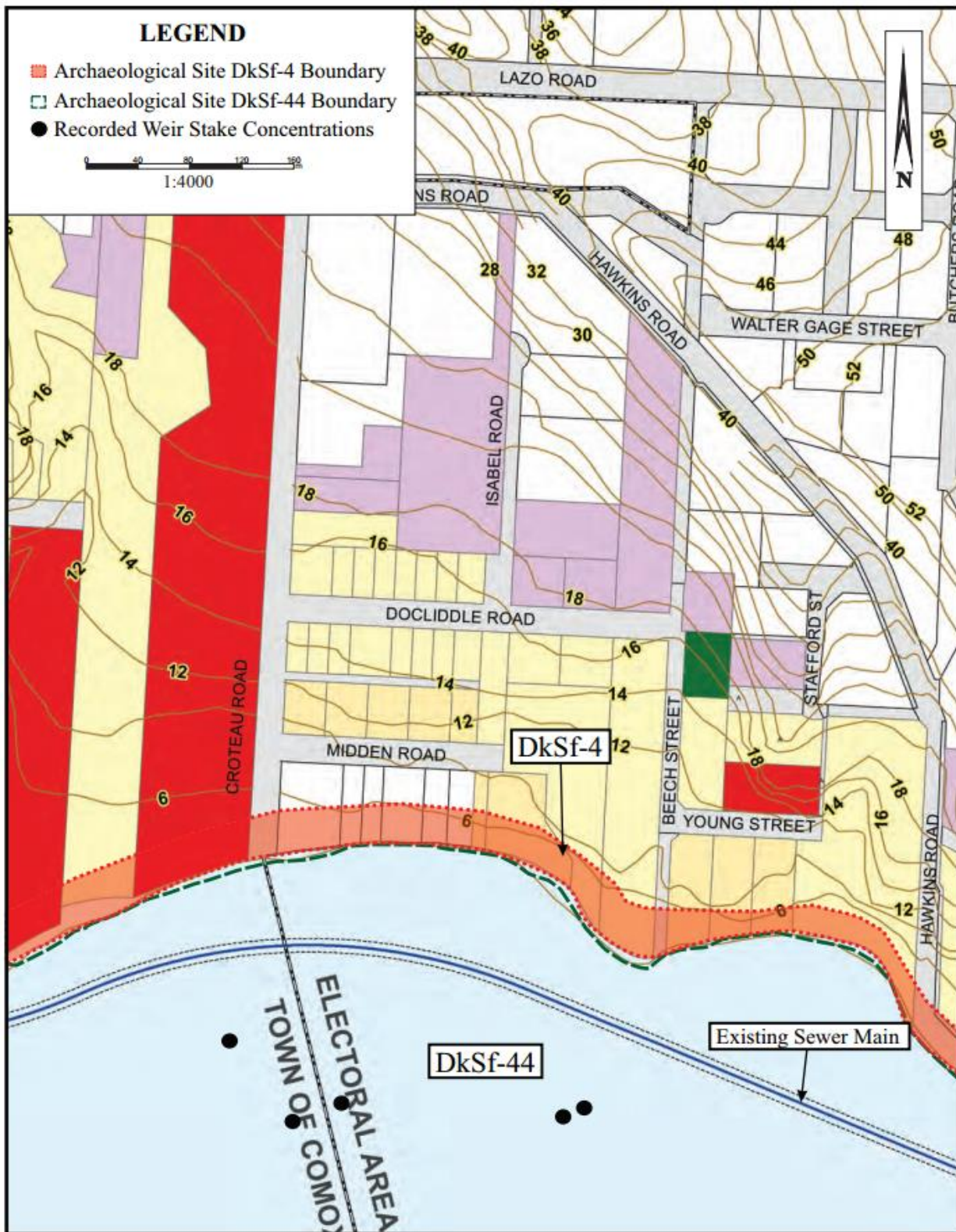

Figure 3-1: Location of Comox and Comox Harbour Sites (Source: Baseline Archaeological)



## 3.2 Environmental (Report to come)

A desktop study and site reconnaissance were conducted for the proposed No. 2 PS property and the alignment by Current Environmental. The complete environmental assessment is attached as Appendix B. All environmental concerns are to be mitigated using the following hierarchy: avoid, minimize, restore on-site, and offset.

### 3.2.1 Pump Station Property

The site is located within a 70 m radius of an active eagle nest tree where the pair has a history of unsuccessfully breeding attempts. A 60 m buffer is required at all times with this distance increased to 160 m during breeding period (April – August). The construction schedule and any vegetation clearing may require avian due diligence. Any future works will require an eagle nest survey to confirm nesting chronology and determine measures to avoid disturbance.

### 3.2.2 Foreshore Tie-In and Beech Street Alignment

The site is within the 561 sq km of the K'omoks Important Bird and Biodiversity Areas (IBA), which recognizes several valued ecosystem components including critical staging and overwintering habitat for migratory and resident waterbirds with highest concentrations in May-Apr when valuable food resources become available with onset of peak herring spawning activity. Any future works will require an nest survey to determine measures to avoid disturbance.

There exist provincially listed ecological communities in upper and lower midlittoral zone. Upper beach is known to support CDFmm/Em02 as well as Em03 and Em04. Fisheries and Oceans Canada has mapped eelgrass beds in the arear which support adult herring reproduction and juvenile rearing however no conflict has been observed during preliminary site reconnaissance.

An active shellfish tenure belonging to the K'omoks First Nations (KFN) overlaps with the existing forcemain in the foreshore however the work area for the tie-in and Beech Street alignment is outside of the tenure boundaries. It is expected that the KFN be meaningfully engaged throughout this project.

Known herring spawning occurs inside of Goose Spit with heaviest concentration in March, lasting for about 4 weeks. Larvae remain in shallow nearshore water for an additional 2 months. Residency of fry emerging from Courtenay River and Brooklyn Creek is known to occur inside of Goose Spit and typically lasts up to 60 days after outmigration of smolts during the spring and early summer.

Work below High Water Mark may require a Request for Review submitted to Fisheries and Oceans Canada but will likely not require a Request for Approval as the project will not result in additional permanent fill below high water mark. Dialogue with Transport Canada may prove beneficial in preventing potential conflicts with TCs Navigation Protection Act.

### 3.2.3 Curtis Road Alignment

Preliminary site reconnaissance revealed no significant environmental concerns along the Curtis Road Alignment. A Section 11 Water Act Notification or Approval might be required should there be any disturbance to fresh water, including channelized watercourses.

Approximately 200 m of the alignment runs through a second growth area where vegetation clearing will be required. Special care must be taken during vegetation clearing as outlined by the applicable sections of the Wildlife Act. Prior to preparing the site for excavation, an avian nest survey may be required to avoid contravention of Section 34 of the BC Wildlife Act and the Federal Migratory Birds Convention Act.

### 3.3 Geotechnical (Report to come)

A site reconnaissance and test pits were conducted at the proposed No.2 PS property and the alignment by exp Services Inc. The complete geotechnical assessment is attached as Appendix C.

Nine testhole were drilled as per Figure 3-2.

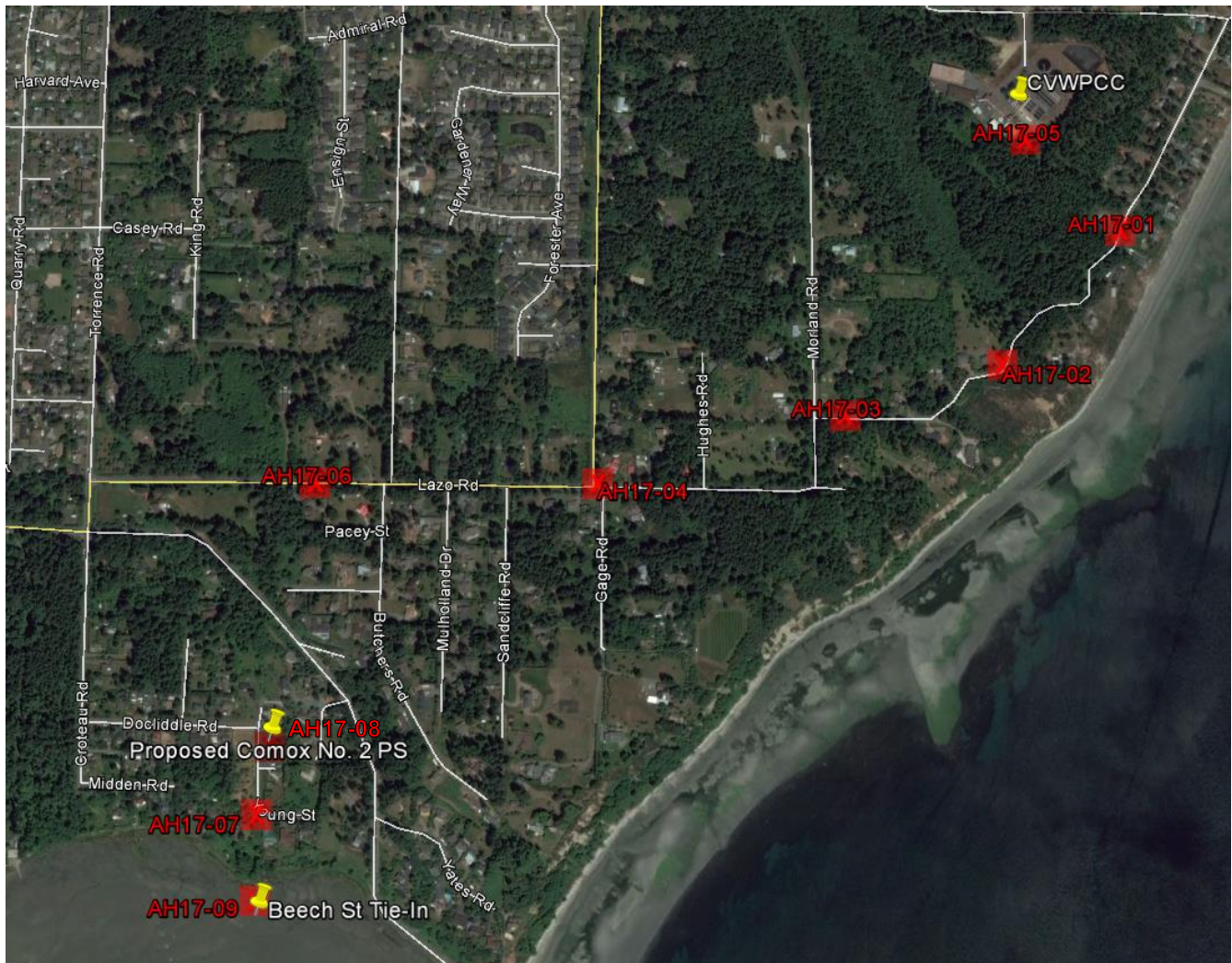

Figure 3-2: Geotech Test Hole Locations (Source: Google Earth)

Table 3-1 show the testhole depths, site location, groundwater levels, and general conditions.



**Table 3-1: Geotechnical Test Holes**

Hole	Depth (m)	Site	Groundwater Levels	General Conditions
AH17-01	4.6	Forcemain alignment	None observed	Mostly sand
AH17-02	6.1	Forcemain alignment	None observed	Mostly sand
AH17-03	4.6	Forcemain alignment	None observed	Mostly sand
AH17-04	4.6	Forcemain alignment	0.9 m visible free water at time of drilling	Mostly sand
AH17-05	6.1	Forcemain alignment	None observed	Mostly sand
AH17-06	4.6	Forcemain alignment	1.1 m visible free water at time of drilling	Mostly sand
AH17-07	4.6	Forcemain alignment	1.8 m visible free water at time of drilling	Mostly silty clay
AH17-08	11.2	No.2 PS property	1.8 m visible seepage at time of drilling 2.0 m measured one day after drilling	Sandy silt, silty clay, silty sand, and sand
AH17-09	6.1	Foreshore	None observed	Mostly sand

Notes:

Test logs can be found in Appendix C.

### 3.3.1 Pump Station Property

Testhole AH17-08 at the No. 2 PS property showed compact to dense sand and shallow groundwater. Although, based on the ground conditions, it is anticipated that limited dewatering would be required during construction as the density of the sand bed will likely prevent water from flowing at high rates into the excavated area. The ground is deemed structurally suitable for the construction of the No.2 PS. A combination of shoring and 1:1 cut slope excavation appears suitable for this construction. Shoring can consist of a number of methods including shotcrete and soil anchors.

### 3.3.2 Foreshore Tie-In and Beech Street Alignment

Testhole AH17-09 at the foreshore showed sand and silty sand, with compact to dense sand at depths of 3.5-6.1 m. No water was observed during the drilling. The ground conditions at this site will likely have implications in terms of what methods of excavation and tidal management will be employed.

### 3.3.3 Curtis Road Alignment

No significant issues were identified based on the preliminary testhole logs. It is anticipated that a 4:1 cut slope with some caging will prove sufficient in supporting the construction of the pipeline.

# Indicative Design

## 4 Conveyance

### 4.1 Design Criteria

A tie-in to the existing 860  $\varnothing$  ID forcemain is proposed with T-connection, at approximately 290 m south of the proposed building. Pipe will be a 1200 mm HDPE pipe, buried approximately 1.2 m with deeper burial leading into and out of the No. 2 PS.

### 4.2 Forcemain Tie-In and Beech Street Alignment

#### 4.2.1 Overview

The length of this tie-in forcemain is optimized at 270 m as it is the closest point of the existing forcemain to the proposed No. 2 PS and maintains the lowest hydraulic grade. This length is based on the assumed location of the forcemain in the mudflats. The pipe alignment would consist of 45 m in the intertidal mud flats, 131 m in undeveloped right-of-way, and 102 m in the paved roadway.



Figure 4-1: Beech Street Tie-In and Alignment (Source: Google Earth)

### 4.2.2 Tie-In

This tie-in would take place at the foreshore, where the pipe is buried approximately 1 m below grade in mud/sand in the intertidal marine environment.

Several critical constraints include:

- Continuously flowing conditions
- Long term material compatibility in the marine environment
- Short work periods between tidal changes
- Lack of information on existing forcemain condition

The proposed tie-in to the forcemain is to be completed through the use of hot tapping, bypassing, and linestopping. The bypass will provide a window where the new forcemain can be tied into the existing forcemain without interrupting operations. Upon completion of the tie-in, the temporary linestop on the upstream side will be removed to redirect flow and the downstream side will be permanently linestopped to discontinue flow in the forcemain.

### Site Preparation and Isolation

Due to the limited work periods between tide changes, the work area is to be dammed to allow for longer working hours for the tie-in. It is anticipated that some type of cofferdam (i.e. aquadam) would be installed to prevent the tide from entering the excavated section and to allow work through tide changes. There may also be need for silt curtains to provide a more workable excavated site for the tie-in. Temporary wooden piles can be used for point loading support and weight bearing throughout.

Based on the footprint and nature of the dam and the excavation, careful environmental and geotechnical considerations must be taken to minimize impact while maximizing safety and working hours.

### T Connection Methodology

The two options for the T-connection at the forcemain tie-in are as follows:

- a. Transition from the existing 860 mm Hyprescon forcemain into an 860 mm HDPE pipe using a concrete elbow, followed by an expansion to a 1200 mm HDPE pipe.
- b. Transition from the existing 860 mm Hyprescon forcemain into an 860 mm HDPE pipe using a material transition fitting, followed by an HDPE elbow and an expansion to a 1200 mm HDPE pipe.

### Tie-In Staging

The general installation approach is envisioned to be as follows:

#### Stage 1

- Installation of the cofferdam around the work zone
- Installation of temporary wooden piles to be used for pipe support

- Excavation of approximately 2.5 m of soil to provide 0.5 m clearance under the pipe using land based excavators within the cofferdam (mini-excavator or similar)
- Stockpiling of material on an adjacent scow or barge (beached). Requires relay using barge mounted long reach excavator

### Stage 2

- Installation of 4 30" x 24" hot-tap saddles. Two located at the 3:00 position facing the foreshore and two at the 12:00 position for line-stops. Installation of 2 30" x 6" hot-taps at the 3:00 position for pressure control
- Denso paste tape of all exposed metal hardware
- Cast-in place lightweight concrete around valves, leaving 2" operating nut and valve stem exposed
- Installation of watertight plug in valve stem

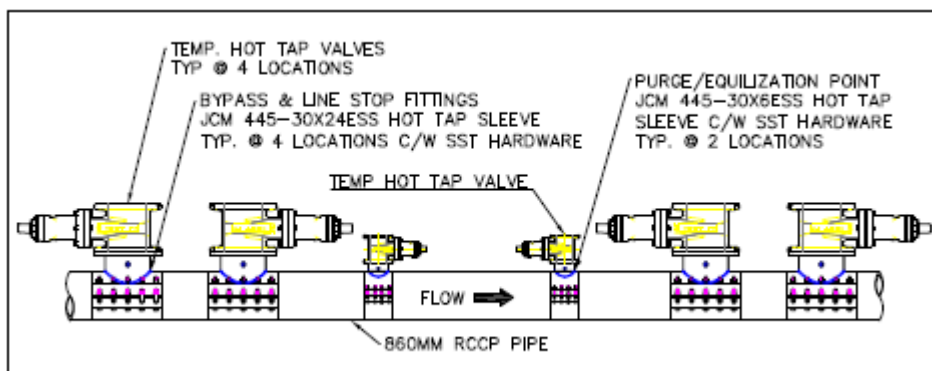

Figure 4-2: Hot Tapping Process (Source: Pacific Flow Control)

### Stage 3

- Installation of 24" by-pass piping around work zone
- Activation of 24" by-pass piping valves
- Retain by-pass for use during pump station commissioning
- Remove cofferdam and bury valves and by-pass

### Stage 4

- Excavate and expose by-pass and valve stems
- Installation of line-stop butterfly plates
- Activate 6" hot-taps and depressurize RCCP line. Drain sewage to foreshore truck and haul to the CVWPPC
- Cut and remove approximately 3 m of RCCP pipe
- Install 90 degree elbow and transition to new HDPE forcemain
- Connect to new pump station
- Remove upstream linestop and allow sewage to flow to new station.
- Cap all valves and bury infrastructure retaining by-pass

### Stage 5

- Excavate by-pass and valves
- By-pass valves
- Remove by-pass piping
- Decommission existing foreshore forcemain
- Concrete encase valve stems and bury

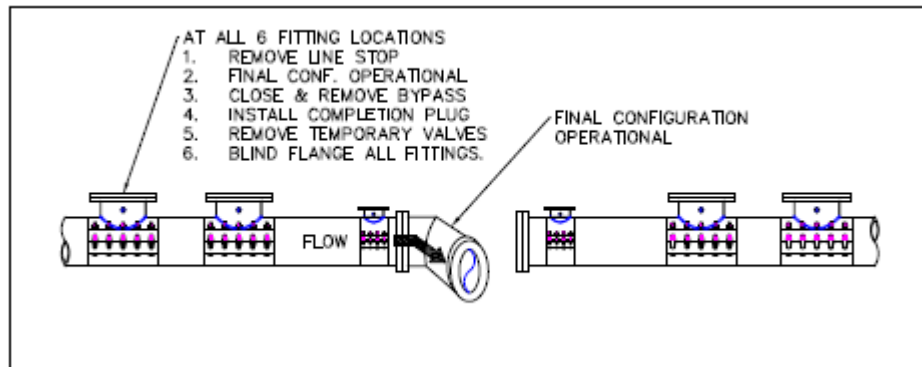

Figure 4-3: Final Configuration (Source: Pacific Flow Control)

### 4.2.3 Alignment

A 1200 mm HDPE pipe conveys the sewage to the No. 2 PS. This forcemain runs north from the foreshore tie-in along the Beech Street right-of-way to the No. 2 PS property where it turns east and discharges into the wet well on the west end of the property.

## 4.3 Alignment to the CVWPCC – Curtis Road

The total length of this alignment from the No. 2 PS to the CVWPCC is approximately 2,400 m. This alignment exits the No. 2 PS on the west side of the building where it turns north, following on the Beech Street right-of-way. It then continues east on Balmoral Road, turns north onto Morland Road and turns east onto Curtis Road. The end section of this alignment cuts through the CVWPCC property towards the plant.

Curtis Road is narrow sandy road that runs along a hill on the east side. Therefore, considerations must be given to excavation methodology in order to address slope stability, interruption to local traffic, disturbance to the vegetation on both sides, and utility conflicts (discussed in Section 14).



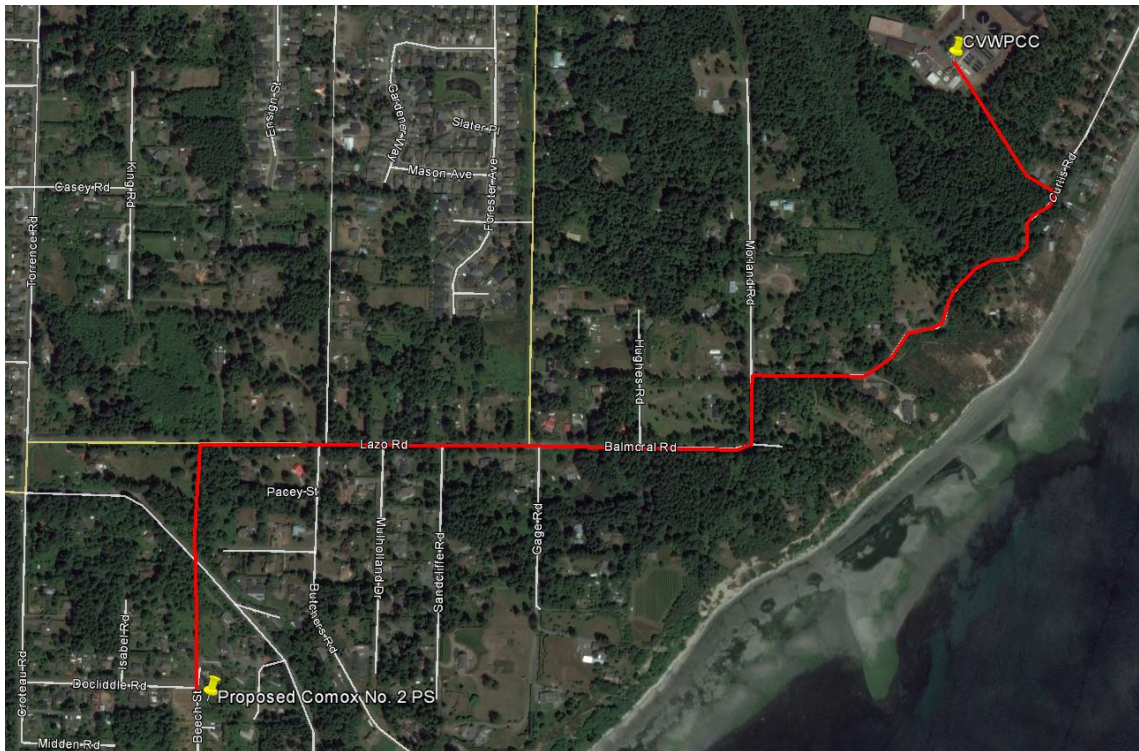

Figure 4-1: Curtis Road Alignment (Source: Google Earth)

## 5 Architectural – Pump Station

The building layout and architectural design of the No. 2 PS will be on the functional requirements while accommodating the utility desired by the CVRD.

### 5.1 Design Criteria

(to come)

### 5.2 General Arrangement

The interior of the building will consist of:

- Wet well
- Dry well
- Odour control room
- Washroom
- Mechanical room
- Electrical room
- Generator room

A sample general arrangement is created and attached in Appendix D.

The wet well is constructed below grade and allows for a paved driveway above. Although the wet well will be vented to prevent any odourous gases from flowing out to the atmosphere, the hatches for the wet well face the West side of the property to divert any potential odour away from the adjacent residents to the North, East, and South. The general arrangement of the pump station requires that the dry well be placed adjacent to the wet well. The position of the odour control room is optimized to allow for ease of ducting for the wet well vent into the odour control system.

### 5.3 Zoning Requirements

The property purchased for the development of the No. 2 PS is zoned as a Country Residential One (CR-1) under the CVRD Zoning Bylaw, 2005 (Bylaw No. 2781) and is to be in compliance with all bylaw setback and lot coverage requirements. As outlined in Section 301 of Bylaw No. 2781, *Uses Permitted In All Zones*, in addition to the uses specifically permitted in particular zones, the following uses are permitted in all zones:

- a. Utility use;
- b. Parks and linear parks;
- c. Ecological reserves;
- d. Community based fish hatcheries;
- e. Composting of waste generated on-site; and
- f. Low impact recreational use.

#### 5.3.1 Height and Setback Requirements

**Table 5-1: Height and Setback Requirements**

Type of Structure	Height m	Required Setback			
		Front Yard m	Rear Yard m	Side Yard	
				Frontage < 31 m m	Frontage > 31 m m
Principal	10	7.5	7.5	1.75	3.5
Accessory	4.5 - or less	7.5	7.5	1.0	1.0
Accessory	6.0 - 4.6	7.5	7.5	1.75	3.5

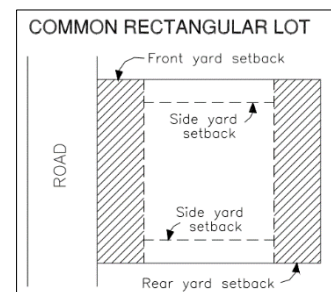

**Figure 5-2: Typical Setbacks**

As per the sample General Arrangement attached in Appendix D, the designed building is in compliance with the above setback requirements for a CR-1 zoning.

#### 5.3.2 Lot Coverage Requirements

As per Section 707, item 5, *Lot Coverage*, the maximum lot coverage of all buildings and structures shall not exceed 35% of the total lot area.

*Lot Coverage* is defined as the total horizontal area of structures measured to the outside of the exterior walls of the buildings and structures on a lot including the horizontal areas of attached decks and porches, expressed as a percentage of the lot area.

According to this bylaw, the allowable coverage area for the No. 2 PS property is 556 m<sup>2</sup>.

Building width and length are estimated at 16.52 m and 30.69 m, respectively, with a total area of approximately 507 m<sup>2</sup>. The total lot coverage area of the designed building is in compliance with the bylaw requirements.

### 5.3.3 Access Requirements

The design of the pump station building must be such the access is provided as follows:

- a. Cleaning wetwell – hydrovac truck, 20 ft hatches for snorkel
- b. Genset removable – 20+ years
- c. Pump hatches – roll up door overhead with monorail
- d. Odour removable – 20+ years
- e. Valves etc. – overhead

## 6 Civil

### 6.1 Design Criteria

The facility is located off Beech Street with an existing drainage path routed around the east and south sides of the property. The property slopes from an elevation of approximately 19 meters at the northern property line to a low point of 14 meter at the south west corner.

#### 6.1.1 Grading

Site grading is retained from the north to the south with the existing drainage path re-established following construction. It is expected that the section of the drainage path at the south side of the property will be moved further south.

Drainage from the parking area will be directed to the existing ditch on Beech Street. The existing 450 mm diameter Corrugated Steel Pipe (CSP) culvert will be replaced and extended to suit the new driveway entrance.

#### 6.1.2 Potable Water

Potable water will be provided from an extension of the Town of Comox water distribution network. A minimum fire protection requirement of 60 L/s is anticipated, to a maximum of 100 L/s. It is anticipated a 300 mm diameter potable watermain will be required. This main will be extended from the intersection of Balmoral Ave and Torrence Road. Further discussions with the Town will be required to confirm the tie-in details at this location. Building water will be supplied from a new service connection on Beech Street.

A backflow preventer is to be used to separate potable water from non-potable water which will be used for pump mechanical seal water supply and washdown hoses.

A hydrant located within the road right-of-way at the intersection of Docliddle Road and Beech Street is proposed.



### 6.1.3 Storm Water

The existing storm water drainage system is to be retained or re-established. Ditch size and culvert capacity shall be confirmed by the final design engineer.

### 6.1.4 Security

A security fence will be required around the site. Wire mesh chainlink fencing with black mesh and landscaping is proposed to minimize the visual appearance of the fence.

### 6.1.5 Landscaping

Detailed landscaping design will be required by the design build contractor. The general intent is to return the ground cover to the existing conditions and additional landscaping screening around the property lines.

## 7 Structural

### 7.1 Design Criteria

The building consists of concrete foundation, walls, and roof, topped with a green roof for sound attenuation and architectural cohesiveness with the neighbourhood. The building will be designed as a post disaster building as required in the most recent BCBC.

Loading criteria is as follows:

- Dead loads
  - » As per weight of materials
- Live loads
  - » Snow load
  - »  $S_s = 2.6$  kPa
  - »  $S_r = 0.4$  kPa
  - »  $I_s = 1.25$  (importance factor – snow)
  - » Floor loading = 4.80 kPa
  - » Wind loads
    - » Hourly wind pressure (1/50 yr) = 0.52 kPa
    - » Hourly wind pressure (1/10 yr) = 0.40 kPa
    - »  $I_w = 1.25$  (importance factor – wind)
- Gross wind uplift (for joist design) = 1.20 kPa for light roof
- Seismic Data
  - »  $S_a(0.2) = 0.66$                        $I_e = 1.50$  (Post Disaster )
  - »  $S_a(0.5) = 0.49$
  - »  $S_a(1.0) = 0.29$
  - »  $S_a(2.0) = 0.16$                       PGA = 0.30

The preliminary recommended slab thicknesses are as follows:

- Base slab; 700 Thk, 700 Projection
- Lower Level (LL) ext. wall thickness 610 Thk., int. wall thickness 400 Thk.
- Slab between LL & UL; 380 Thk.
- Upper Level (UL) ext. & Int. walls 300 - Thk.,
- Roof Slab 350 Thk.

The following is recommended:

- a. 0.3 mm crack width + outside wall waterproofing to prevent leakage into dry room to save rebar
- b. epoxy coated rebars for wet well walls

## 7.2 Land Features

(To come)

# 8 Process Mechanical

## 8.1 Design Criteria

The initial design is based on a current flowrate of 1,000 L/s as shown on Figure 8-1:

- Basis of design pump is a Flygt 385HP model
- Three duty pumps and one standby
- Genset is 1500 kW to allow for the operation of three duty pumps. Genset is sized to allow for the operation of the fourth pump

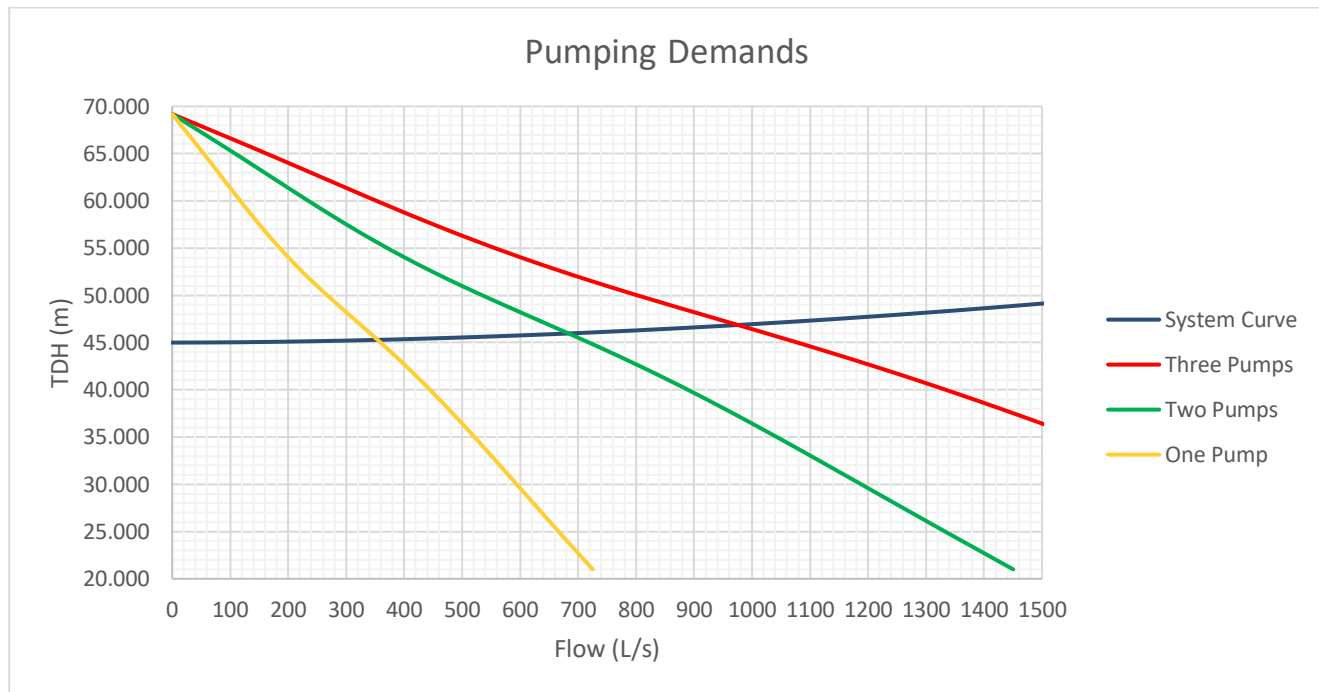

Figure 8-1: System Curves

Provision incorporated for an increase in flow up to 1,500 L/s.

- Would require the installation of a fifth pump resulting in four duty pumps and one standby. Pumps would be 385HP Flygt models
- Genset remains at a 1500 kW unit which would allow for the operation of all four duty pumps. the genset is not sized for the operation of 5 duty pumps

## 8.2 Wet Well and Dry Well

The pump station will employ a wet well and dry well style installation as per process flow diagram in Appendix D.

### 8.2.1 Wet Well

The wet well minimum structural dimensions are based on Hydraulic Institute Standard 9.8, Rotodynamic Pumps for Pump Intake Design, Appendix E.

The wet well width is maximized and extended to the property line in order to provide additional volume to accommodate transient variations of the incoming flow. An active wet well operating depth of 2.4 m is used for on and off staging of the duty pumps. Wet well will have two access hatches and ladders for entry. A walking platform and railing is provided. This will allow for wet well cleaning and to access level instrumentation.

Air will be provided to the wet well from a supply fan located in the odour control room. Ducting is provided in the wet well to distribute and mix air. Air will be exhausted from the wet well to the odour

control system in the odour control room. 30 air changes per hour is to be provided when the wet well is to be accessed and the ventilation is to be turned down when the wet well is closed. The air volume to be ventilated in the wet well is from the invert of the inlet pipe.

### 8.2.2 Dry Well

The pumps are located in the dry well with a suction pipe routed to the wet well and inlet bell located within the wet well. The inlet bell sizing is based on Hydraulic Institute Standard 9.8, Appendix F. The minimum submergence on the inlet bell in order to eliminate subsurface vortices is calculated based on Hydraulic Institute Standard 9.8 formula.

Dry well designed for ultimate installation of 5 pumps. Minimum 900 mm between pumps. Minimum 2m room behind pumps for operations and maintenance. A minimum of 6 air changes per hour is required into the lower dry well in order to be an unclassified environment.

Clockwise isolating gate valves are required in the inlet and discharge of each pump. Clockwise check valves are required on the discharge of each pump.

### 8.2.3 Operations

Wet well operation will be level based. Lead and lag pumps will start and stop based on level setpoints and operate to maintain a set level once started. A first in, first out philosophy will be used to ensure adequate pump alternation.

- High high level alarm
- Pump 4 start level (future for 1,500 L/s operation)
- Pump 3 start level
- Pump 2 start level
- Pump 1 start level
- Pump 1 stop level
- Pump 2 stop level
- Pump 3 stop level
- Pump 4 stop level (future for 1,500 L/s operation)
- Low low level alarm

### 8.2.4 Emergency Storage and Shut Down

Due to space constraints, the wet will cannot be sized to accommodate emergency storage. The option of providing emergency storage in a pipeline underground is also deemed unfeasible for this area.

Based on the sample general arrangement, there is 10 minutes of storage in the wet well at flows of 1000 L/s inflow. This is from the pumps stop level in the wet well.

If, in case of an emergency, the pump station is to be turned off, each pump would need to be individually turned off with the associated hand-off-auto selector switch. The sluice gate to the wet well is to be equipped with a fail-safe motorized actuator. The implications of sudden closure of this gate is that the Courtenay and Jane pump stations will be at risk for overflowing.

## 9 Building Mechanical

### 9.1 Heating and Ventilation Requirements

The following heating and ventilation requirements are consistent with the sample general arrangement in Appendix D and are to be adjusted based on the final design as required.

**Table 9-1: Heating and Ventilation**

Room	Heating Temperature Setpoint (°C)	Ventilation Temperature Setpoint (°C)
Genset	N/A	22
Electrical	15	22
Washroom	N/A	22
Storage	N/A	22
Odour Control	15	N/A
Drywell Lower	15	N/A
Drywell Upper	15	22
Wetwell	N/A	N/A

The lower dry well and odour control room are constantly ventilated at a minimum of 6 air changes per hour. This is to ensure the areas are “unclassified” per the Canadian Electrical Code (CEC). Heating is to be provided to maintain minimum 15°C.

The upper dry well will be ventilated and heating will be provided to maintain a minimum of 15°C.

The electrical room will have a fan which will ventilate the room and provide free cooling. A heat pump will be used to cool the room so the interior temperature does not exceed 22°C and heat the room so the temperature does not fall below 15°C.

The washroom will have an exhaust fan and air will be drawn into the washroom from the adjacent interior environment.

Ventilation control for areas other than the wet well, lower drywell and odour control room will be based on occupancy, time of day and interior temperature. DDC or PLC control is required for the heating, cooling and hvac systems.

### 9.2 Pump Station Area Classification and Air Changes

**Table 9-2: Room Classifications**

Room	Area Classification	Required Ventilation Air Changes
Genset	unclassified	N/A
Electrical	Unclassified	N/A
Washroom	Unclassified	N/A
Storage	Unclassified	N/A
Odour Control	Unclassified	6 air changes per hour in order to be an unclassified area
Drywell Lower	Unclassified	6 air changes per hour in order to be an unclassified area

---

Room	Area Classification	Required Ventilation Air Changes
Drywell Upper	Unclassified	N/A
Wetwell	Class 1 Zone 1	30 air changes per hour for access

---

## 10 Odour Control

### 10.1 Design Criteria

An odour control system (or a combination of a primary and secondary) is to be employed that will achieve no odour at the pump station property line. The odour control units are to be integrated as per process flow diagram in Appendix D.

### 10.2 Primary – Activated Carbon Scrubber

The odour control room to house system sized for 30 wet well air changes as described in previous sections.

Minimum air required into the room is at 6 air changes per hour in order to be an unclassified environment. With the air changes the room is an unclassified environment except for area within 900 mm of leakage points (access panels, flexible connections, etc.) where the rating is Class 1 Zone 2. All electrical equipment installed within the room that is not part of the package odour control system is to not be installed within 900 mm of leakage points.

### 10.3 Secondary – Biofilter

A secondary odour control system may be implemented to provide a second layer of polishing and dispersion for the outgoing air vented from the wet well. The system is to be designed for a 3-minute retention time. Special consideration is to be given to the location and size of the biofilter.

## 11 Noise and Vibration

### 11.1 Baseline Noise Monitoring

A 24-hour noise monitoring exercise was undertaken to establish a baseline for the level of noise for the Croteau neighbourhood.

Figure 10-1 shows the primary (24-hour) and secondary measurement (Short-Term) locations around the proposed Comox No. 2 Pump Station location (outlined in red). Short-term Position 1 was located along the gate at the western property edge while Short-term Position 2 was located near the power pole on the south-west corner of the property. Water noise from the creek can only be audible in Short-term position 2. Short-term measurements were done immediately after setting up the 24-hour monitor (between 12:30 and 13:00), and again at night between 23:00 and 23:30.

During the daytime, the dominant observed noise source was birdsong. At night, a helicopter and boat could be heard for part of the half hour period.

In analysing the noise monitoring data, two different metrics were employed:  $L_{eq}$  is an average of all the sounds recorded during the monitoring period and is strongly influenced by the loudest events occurring because these events contain most of the sound energy. The second metric,  $L_{90}$ , represents the sound level present for at least 90% of the duration of the noise monitoring (21 hours and 36 minutes in this case). Using the recorded  $L_{90}$  as the baseline will therefore not account for any intermittent loud noises such as boats, helicopter, and cars.

The difference in noise levels at both short-term positions compared to the 24-hour position was less than 1 dBA. Therefore, the primary measurement location can be considered to be representative of the immediate area around the proposed Comox No. 2 Pump Station.



Figure 11-1: Measurement Positions

Table 11-1: Noise Baseline

Time	Hours Represented	$L_{eq,T}$ (dBA)	$L_{90}$ (dBA)
Day	12:30 - 22:00 May 25; 07:00 - 12:30 May 26	44	35
Night	22:00 - 07:00 May 25-26	41	25
24 hours	12:30 - 12:30 May 25-26	43	26

## 11.2 Resultant Design Criteria

Noise and vibration are to not be perceptible beyond the pump station property line. The maximum noise level during regular operations is not to exceed 35 dBA. The noise would be estimated to be around 20 dBA within the adjacent buildings which is below the WHO recommended sleeping level of 30 dBA. During emergency situations, noise levels up to 65 dBA will be anticipated.

## 11.3 Noise Mitigation

To mitigate noise pollution from the No. 2 PS, the following components and techniques are to be incorporated into the design:

1. Concrete construction, green roof, buried walls and acoustic wall panels.
2. Sound pods on the in/out air systems; and
3. One silencers on the air inlet and discharge, each.

## 12 Electrical, Instrumentation, and Controls

### 12.1 Design Criteria

The electrical system and electrical equipment must provide the highest level of safety and functionality, and must incorporate the principles of environmental safeguards, protection of the process equipment, economy of operation in all regards, and high reliability.

**Table 12-1: Design Parameters**

Primary High Voltage Distribution	To be confirmed
Low Voltage Secondary Distribution	600 V 3 Phase 60 Hertz
Equipment Voltage Ratings	
AC Motors 1 HP up to and including 200 HP	575 V 3 Phase 60 Hertz
AC Motors up to 600 HP with AC Variable Frequency Drives	575 V 3 Phase 60 Hertz (600 VAC input)
Lighting	
LED	120 VAC
Control Voltages	
Discrete	120 VAC
Analog	1-5 VDC, 4-20 mA

### 12.2 Electrical Power Supply

The Comox pump station would be supplied from a new BC Hydro overhead distribution line adjacent to the site through a pad mount transformer (PMT). BC Hydro does not foresee any issues connecting to the existing 25 kV overhead line. However, an engineering study would be required by BC Hydro once electrical SLD, detailed site layout and load lists are submitted. BC Hydro will own and operate transformers up to a maximum of 1500 kVA (the nominated transformer size for No. 2 PS). Therefore, the transformer is to be designed as per BC Hydro standard. The PMT will be located within the site boundary. Based on the estimated site load, BC Hydro would typically supply this PMT (up to a maximum size of 1500 kVA). This will be confirmed after consultation with BC Hydro during detailed design.

It is expected that the BC Hydro feeder coming into site will be buried underground from the nominated distribution line pole to the PMT. As per preliminary assessment in section 12.3, the site maximum demand is approximately 1583 kVA.

The PMT will be installed adjacent to the MCC room. The overall transformer area (with counterpoise) is approximately 4200 x 4200 mm. BC Hydro advises a minimum clearance of 3 meters from building walls. If the 3 metres distance to building wall is not maintained, a separate grounding study is to be submitted to BC Hydro for their approval. BC Hydro may also request to witness grounding system commissioning tests. A suitable location of this PMT will be determined during detailed design.



All cables shall be installed in conduits from the nearest BC hydro distribution line pole to site. The PMT will be installed on a concrete pad and cable conduits will be installed from the PMT to the designated MCC room.

### 12.3 Estimated Site Maximum Demand

The estimated site maximum demand is based on the preliminary review of the site layout and associated electrical loads. The estimated maximum demand are based on the following:

**Table 12-2: Estimated Site Maximum Demand**

No	Load Description	Voltage (V)	Size (kVA)
1	Distribution Pumps (4x385 HP)	600	1436
2	Air Compressor (x1)	600	4.7
3	Building Heater (x2)	600	12.5
4	Distribution Panels (lighting, auxiliary power, utilities etc.) (x2)	120/ 208	75.0
5	Unit Heater (x1)	600	12.5
6	Building Ventilation Fans (x2)	600	9.3
7	Wet Well Fans (x4)	600	11.2
8	Odour Control Fan (x1)	600	9.3
9	Odour Control Heater (x1)	600	12.5
		<b>Total</b>	<b>1583</b>

The above maximum demand will be confirmed during detailed design.

### 12.4 Motor Control Centre

A Motor Control Centre will be provided inside the pump station which will include the following equipment:

- 1600A, 600V three phase main circuit breaker;
- BC Hydro Metering;
- Surge Protection Device (SPD);
- 1600A Automatic Transfer Switch (ATS);
- Power Quality Monitor (PQM);
- 600/120-208V distribution transformers and panel boards;
- Variable frequency drives (VFD) c/w line and load filters;
- Uninterruptible Power Supply (UPS) and UPS bypass switch for control power and instrumentation; and,
- Control Section.

Typical MCC manufacturers would be Eaton, Cutler Hammer, Square-D, Allen Bradley or Siemens.

Four (4) VFD panels complete with suitably rated VFD, line/ load filters will be provided for the 300 HP distribution pumps. The pump feeder panels will be capable of supplying 300 HP distribution pumps each.

### 12.4.1 Pump Motor Starters

Eaton 18 pulse VFD starter c/w line and load filters will be specified for the main 385 HP distribution pumps.

As shown on the electrical single line diagram, selected pumps/fans will be provided with variable frequency drives (VFD) that would allow the units to operate at variable speed and permit smooth pump starting and stopping.

For all other pumps/fans, across the line (ACL) starters will be specified. Any pumps and fans  $\geq 50$  HP will be equipped with a soft starter or VFD.

Each pump starter will be mounted in an enclosure and will include the following:

- Motor Circuit Protection. This MCP will also permit locking and tagging out of the motor for maintenance purpose;
- Non-resettable elapsed hour meter;
- Hand-Off-Auto selector switch;
- Running, Standby and Fault indication lights;
- Door mounted Soft Starter keypad.

The VFD starter status and controls will be hardwired to the station control system as follows:

- MCP tripped
- Pump Running
- VFD Fault
- H-O-A selector switch Not In Auto
- VFD speed reference
- VFD speed feedback
- VFD start and stop

Remote pump monitoring will include:

- Motor Circuit Protector tripped;
- Pump Running;
- Hand-Off-Auto selector switch in Auto position;
- Hand-Off-Auto selector switch in Hand position;
- Motor winding over-temperature;
- Motor Seal Leak.

Motor current and other VFD diagnostic information will be monitored through the communication system back to the station control system. The communication system detail will be confirmed during detailed design.

Typical Drive manufacturers would be Mitsubishi/MGI, Yaskawa, Vacon, Schneider/Altivar, Eaton, Allen Bradley, Danfoss, Siemens, ABB, Toshiba or Benschaw.

### 12.4.2 Motor Control Centre Dimension

Estimated overall MCC and the separate 300 HP VFD panel sizes are given below:

**Table 12-3: Equipment Dimension**

No.	Equipment	L x H x D (mm)
1	MCC (x1)	11500 x 2286 x 510
2	VFD Panel (x4)	1800 x 2286 x 635

## 12.5 Back-Up Generator

The 1500kW genset sized for four operating 400HP pumps. Air inlet requirements is approximately 100,000 cfm. Sound attenuation to be provided on genset inlet ducting, exhaust ducting, and room interior. A 1.5 m high inlet louvre is approximately 15 m long.

A 1250 kW standby generator (Genset) is provided as a backup power supply to the station in case of an outage of the BC Hydro supply. The generator will be able to supply three (3) 385 HP pumps and the pump station building loads. It will be installed in a separate generator room.

The Genset will be designed with a dual-walled sub-base fuel tank complete with fuel system including an accessible fuel filler pipe with sufficient capacity for 24-hours of continuous engine operation at the fully rated Genset capacity. The fuel transfer will be from a fuel delivery truck equipped with a transfer pump and heavy-duty rubber hose terminated with a heavy duty pistol grip nozzle. The generator fuelling system will be confirmed during detailed design.

The generator cooling and exhaust system will be confirmed during detailed design.

A minimum of three discrete alarms/ status will be provided for connections to the RTU via the station communications system:

- Genset running
- Genset warning alarm
- Genset shutdown

Typical genset vendor/ manufacturers would be: Cummins/Onan, Cullen/MTU, Finning/Cat, Simson Maxwell/Simmax or Total Power/Generac.

The anticipated lead time for the back-up generator is 16 to 20 weeks.

## 12.6 Electrical Appurtenances

Electrical appurtenances include security lighting, indoor lighting and emergency lighting.

### Lighting

Energy efficient LED light fixtures will be utilized for the station and operated manually by a wall switch located inside the building near the entrance of each room.

Fully automatic emergency exit lights will be provided c/w main battery pack unit and rated for a minimum one hour system operation.

Exterior lighting will be LED Wall Pack with photocell. In Automatic mode, the lights will be controlled by the photocell.

### **Receptacles**

Convenience wall receptacles will be provided within the pump station. Location of the receptacles will be confirmed during detailed design. All wall receptacles will be fed from GFI circuit breakers in the panel board.

### **Fire Alarm System**

A suitable fire alarm system will be installed at the pump station. Details of the fire alarm system will be confirmed during detailed design.

### **Security System**

A suitable security system will be installed at the pump station. Details of the security system will be confirmed during detailed design.

## **12.7 Instrumentation & Controls**

### **12.7.1 Instrumentation**

The duty pumps will operate based on the wet well level. The pumps will be operated through VFDs and PID control system to maintain a set wet level. Suitable pressure transducer will be required. Their installation location will be confirmed during detailed design. Flowmeter will be installed outside the station in a suitable chamber. This will be confirmed during detailed design.

Pressure transmitter and flow meter data will be displayed on a remote panel. The remote panel will have a programmable keypad and 4-20 mA outputs for connection to the station control system. Typical pressure transmitter manufacturers would be Siemens DSIII 7MF4033, Endress & Hauser PMC71, Foxboro IGP, Rosemount 2088 or ABB 261GS. Typical flowmeter would be Siemens Sitrans 5100W/5000, Endress & Hauser Promag 50W, Foxboro, Rosemount 8705/87-2, Krohne Optiflux 2000-010, McCrometer UM-06 or ABB Water Master FEV/FEV.

Requirement for a building air temperature monitoring will be confirmed during detailed design.

### **12.7.2 Control System**

The proposed control system will be based on an Allen Bradley Compactlogix or Controllogix system. A HMI touch screen will be provided for easy adjustment of the station operating parameters and to display station status and alarms. The programming of the control system would be completed as part of the pump station design and commissioning. All components of the control system are to be fully redundant.

Detail control system architecture will be confirmed during detailed design.

### 12.7.3 Plant Process Area Designations and Tag Systems

Control system inputs and outputs (I/O) will reference the equipment by its tag number. This number will also appear on P&IDs, location drawings, schematics and loop drawings.

### 12.7.4 Alarm System

Major station alarms will include:

- Power failure
- Intrusion
- Surge Suppressor Fault
- UPS Low Battery
- UPS Bypassed
- Building Low temperature
- Pump Not In Service
- Pump failed to start
- Drive Fault
- Inlet Pressure Low
- Outlet Pressure Low
- Outlet Pressure High
- Station Flow low
- Genset Alarm
- Genset Shutdown
- Communication Failure
- RTU Failure
- Motor High Vibration Alarm
- Standby Generator Low-Fuel Alarm

## 12.8 Communication Systems

### 12.8.1 Fibre Optic Site Communication

A dedicated fibre-optic communication line will be provided for the pump station. It will support the communication between the pump station and the Waste Water Treatment Plant (WWTP) for the SCADA system. The Fibre Optic system will use single mode fibre and should contain a minimum of 6 strands. The conduit for the fibre will be installed when the new waste water pipeline is installed.

A telephone system will be provided at the pump station. It will be a VoIP based telephone system connecting back to the WWTP. This will be supported on the new fibre optic circuit.

Signals for the security alarm system will also be communicated through the fibre optic circuit back to the WWTP.



## Archaeological

Under Section 12 of the *Heritage Conservation Act*, a Site Alteration Permit (SAP) is required for development within the archaeological site boundary of Comox Harbour - DkSf-44 and Comox - DkSf-4 with a condition of archaeological monitoring as well as a testing methodology in advance of the construction for potentially intact deposits for DkSf-4.

# 14 Utility Coordination

## 14.1 Request for Information

An underground utility locate request was conducted by Opus through BCOne Call. A description of the proposed work and a map showing the Forcemain Tie-In, Beech Street alignment, and the Curtis Road alignment were provided to the utility owners for their reference.

In response to the underground utility locate request, the utility owners provided the following information:

- FortisBC – Utility maps and safe digging procedures
- BC Hydro – Utility maps and typical underground cross section
- Town of Comox – GIS utility maps adjacent to the proposed alignment and an email confirming that there is no conflict with the proposed alignment
- Telus – Email confirming that there is no conflict with the proposed alignment.
- Canadian Forces Base Comox - Email confirming that there is no conflict with the proposed alignment. (only for the Curtis Road Alignment)
- DigShaw - Email confirming that there is no conflict with the proposed alignment.

### 14.1.1 Forcemain Tie-In and Beech Street Alignment

Based on the information provided by the utility owners, no conflict was identified in this area.

### 14.1.2 Curtis Road Alignment

Based on the information provided by the utility owners, only FortisBC utilities conflicts the Curtis Road sewer alignment. The proposed sewer main alignment crosses FortisBC's 60 mm DP gas main twice along Beech Street; Once at Hawkins Road and the other at Walter Gage Road. In addition, the sewer main section from Morland Road to the CVWPCC (From property 247 to 378) runs parallel with FortisBC's 60 mm DP gas main. Trenching in this section will require coordination, mitigation, and potential relocation with FortisBC. The parallel section crosses three 26 mm DP gas main service connection (Property 247, 281, and 301) along Curtis Road.

# Cost Estimate

The preliminary cost estimate of the project, split by discipline, is as follows:

<b>Discipline</b>	<b>Estimated Cost</b>	
General		\$1,341,358
Civil – Alignment		\$6,285,729
Civil – Site		\$632,489
Structural		\$1,960,953
Architectural		\$362,689
Process – Mechanical		\$1,383,534
Plumbing		\$120,000
HVAC		\$299,531
Electrical		\$2,254,557
Instrumentation		\$4,497
<b>SUB-TOTAL</b>		<b>\$14,645,337</b>
Class B Contingency	15%	\$2,196,800.62
Construction Contingency	10%	\$1,464,534
<b>TOTAL (INCL. PST)</b>		<b>\$18,306,672</b>

The total cost of the two main components of the project (including PST and contingencies) are as follows:

<b>Item</b>	<b>Estimated Cost</b>
Alignment (including contingencies)	\$7,857,161.25
Pump Station (including contingencies)	\$10,449,510.00
<b>TOTAL (INCL. PST)</b>	<b>\$18,306,672</b>



## **APPENDIX A – ARCHAEOLOGICAL REPORT**

**Report For**  
**The Archaeological Overview Assessment and Preliminary**  
**Field Reconnaissance of the Proposed South Sewer Project**  
**Royston to Cape Lazo Outflow Segment**

**Prepared For:**

**Comox Valley  
Regional District  
South Sewer Project Office**

**Prepared By:**

**Baseline**  
archaeological services ltd.

556 Harmston Avenue  
Courtenay, BC  
V9N 2X5

December 2015

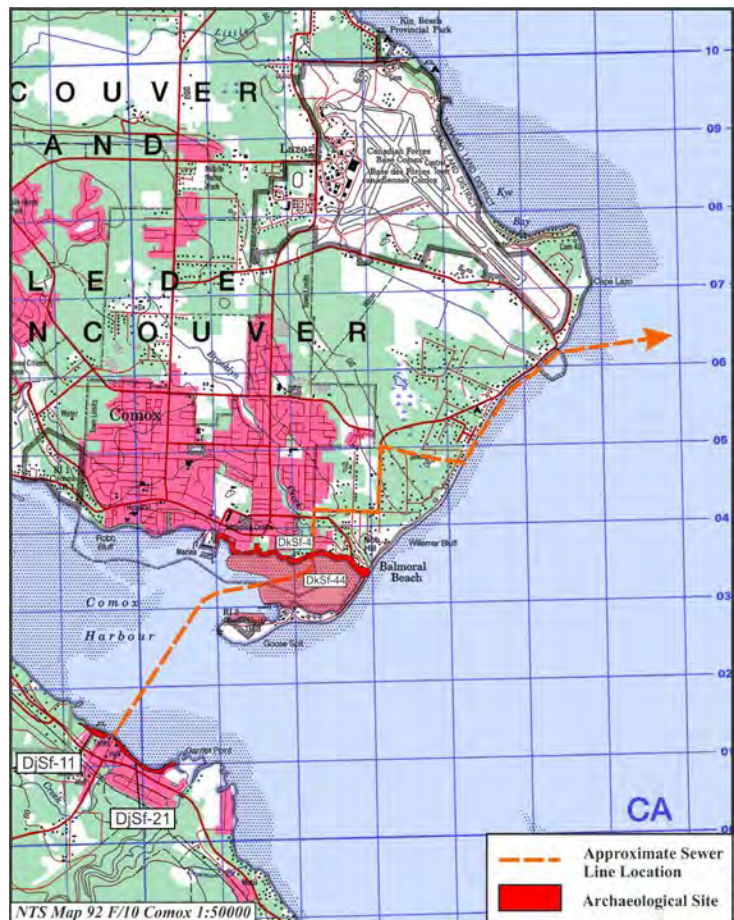

## Management Summary

---

This report summarizes the results and recommendations of an archaeological overview assessment (AOA) and preliminary field reconnaissance (PFR) conducted by Baseline Archaeological Services Ltd. (Baseline) of the portion of the proposed South Sewer Project (SSP), located between Royston and the Cape Lazo outfall.

The proposed south sewer project (SSP) phase 1 includes a waste water treatment facility (WTF), collection and conveyance system for the Union Bay and Royston Areas, and an outfall to Cape Lazo. For the purposes of this report, the focus will be on the portion of the SSP outfall pipeline from Royston Road to the outfall at Cape Lazo. The wastewater will be treated within the CVRD south region, and the effluent will then be pumped across the estuary/ Comox Harbour, through a 14 inch pipeline from the base of Royston Road. The effluent pipeline will run next to the planned Comox Pump Station #2 to be built at the base of Croteau Road. Once past the pump station, the smaller effluent pipeline from the SSP will follow the sewer main (a much larger pipe) across the Comox Peninsula to the Comox Valley Water Pollution Control Centre (CVWPCC). Both the sewer main and effluent pipeline will travel inland along Croteau Road, generally following Lazo and Brent Roads to the CVWPCC. From the CVWPCC a single combined effluent pipeline would cross Curtis Road and run along the intertidal area to the Cape Lazo outflow in the vicinity of Point Holmes before heading out to the sea.

The AOA included background research of the development area to determine which archaeological sites were potentially in conflict with the project. The PFR involved pedestrian and vehicular traverses of the development and related archaeological sites. The PFR was conducted by Chris Engisch (Baseline) and Ron Mitchell (Komox First Nation) in September and November 2015.

The AOA identified four archaeological sites in potential conflict with the proposed development.

**Royston:** Shell midden site **DjSf-21** is located at the base of Royston Road, with **DjSf-11** being located immediately to the northwest (*Figure 1 & 2*). It is likely the finalized location of the effluent line will be within the boundary of one of these sites.

**Comox Harbour:** Fish weir site **DkSf-44** (Goose Spit Fish Trap Site) is located within the intertidal area below Croteau Road (*Figure 1 & 3*). The proposed development will take place within the boundary of the site, but the finalized location may or may not impact actual archaeological features within the site.

**Comox:** Shell midden site **DkSf-4** is located within the backshore of Comox Harbour and in the development area of the effluent line and pump station (*Figure 1 & 3*).

Recommendations for the development of this project would include obtaining a Section 12, Site Alteration Permit (SAP) from the BC Archaeology Branch. The permit would include conditions for further archaeological work relating to the impact of archaeological material during the construction process, dependent on the condition and volume and type of material being impacted.

## **Table of Contents**

---

MANAGEMENT SUMMARY.....	2
INTRODUCTION.....	5
PROJECT AREA .....	7
ARCHAEOLOGICAL BACKGROUND OF THE STUDY AREA .....	7
EXPECTED SITE TYPES .....	8
METHODOLOGY .....	9
RESULTS / COVERAGE.....	10
IMPACT ASSESSMENT .....	15
RECOMMENDATIONS .....	16
REFERENCE LIST.....	19

### **LIST OF FIGURES**

Figure 1. LOCATION OF ARCHAEOLOGICAL SITES AND DEVELOPMENT AREA .....	6
Figure 2. LOCATION OF ROYSTON SITES.....	11
Figure 3. LOCATION OF COMOX AND COMOX HARBOUR SITES .....	14

### **LIST OF TABLES**

Table 1. SUMMARY OF RECOMMENDATIONS.....	17
--	----

## Introduction

---

Alexandra Hitchcock of the Comox Valley Regional District (CVRD) South Sewer Project (SSP) contacted Baseline Archaeological Services Ltd. (Baseline) and requested that an AOA and PFR be undertaken for the portion of the project linking Royston to the Cape Lazo outflow. This was requested to determine which archaeological sites were in conflict with the proposed development and what type of further archaeological work and permitting would be required for the project.

The work reported herein consists of an AOA and PFR as defined in the *British Columbia Archaeological Impact Assessment Guidelines* (1998). This report is concerned with identifying any known archaeological sites in conflict with the development area, and making management recommendations on how to proceed in the event of conflict between existing archaeological materials and proposed ground altering activities. It is also concerned with determining the potential for any unrecorded archaeological material. This report does not address any First Nations interest in the land. The study was conducted without prejudice to First Nations treaty negotiations, aboriginal rights, or title.

Archaeological sites are defined as locations which contain physical evidence of past human activity, such as artifacts or features. A list of expected site types that would likely be identified on the subject properties is provided later in the report under Expected Site Type. Archaeological remains which predate, or are likely to predate 1846 are automatically protected from any form of alteration, excavation, damage or desecration in British Columbia under the *Heritage Conservation Act (HCA)*. Other sites protected under the *HCA* include aboriginal rock art sites with historical or archaeological value, burial places and historical shipwrecks.

The proposed south sewer project (SSP) phase 1 includes a wastewater treatment facility (WTF), collection and conveyance system for the Union Bay and Royston areas, and an outfall to Cape Lazo. For the purposes of this report, the focus will be on the portion of the SSP outfall pipeline from Royston Road to the outfall at Cape Lazo. The wastewater will be treated within the CVRD south region, and the effluent will then be pumped across the estuary/Comox Harbour, through a 14 inch pipeline from the base of Royston Road. The effluent pipeline will run next to the planned Comox Pump Station #2 to be built at the base of Croteau Road. Once past the pump station, the smaller effluent pipeline from the SSP will follow the sewer main (a much larger pipe) across the Comox Peninsula to the Comox Valley Water Pollution Control Centre (CVWPCC). Both the sewer main and effluent pipeline will travel inland along Croteau Road, generally following Lazo and Brent Roads to the CVWPCC. From the CVWPCC a single combined effluent pipeline would cross Curtis Road and run along the intertidal area to the Cape Lazo outflow in the vicinity of Point Holmes before heading out to the sea.



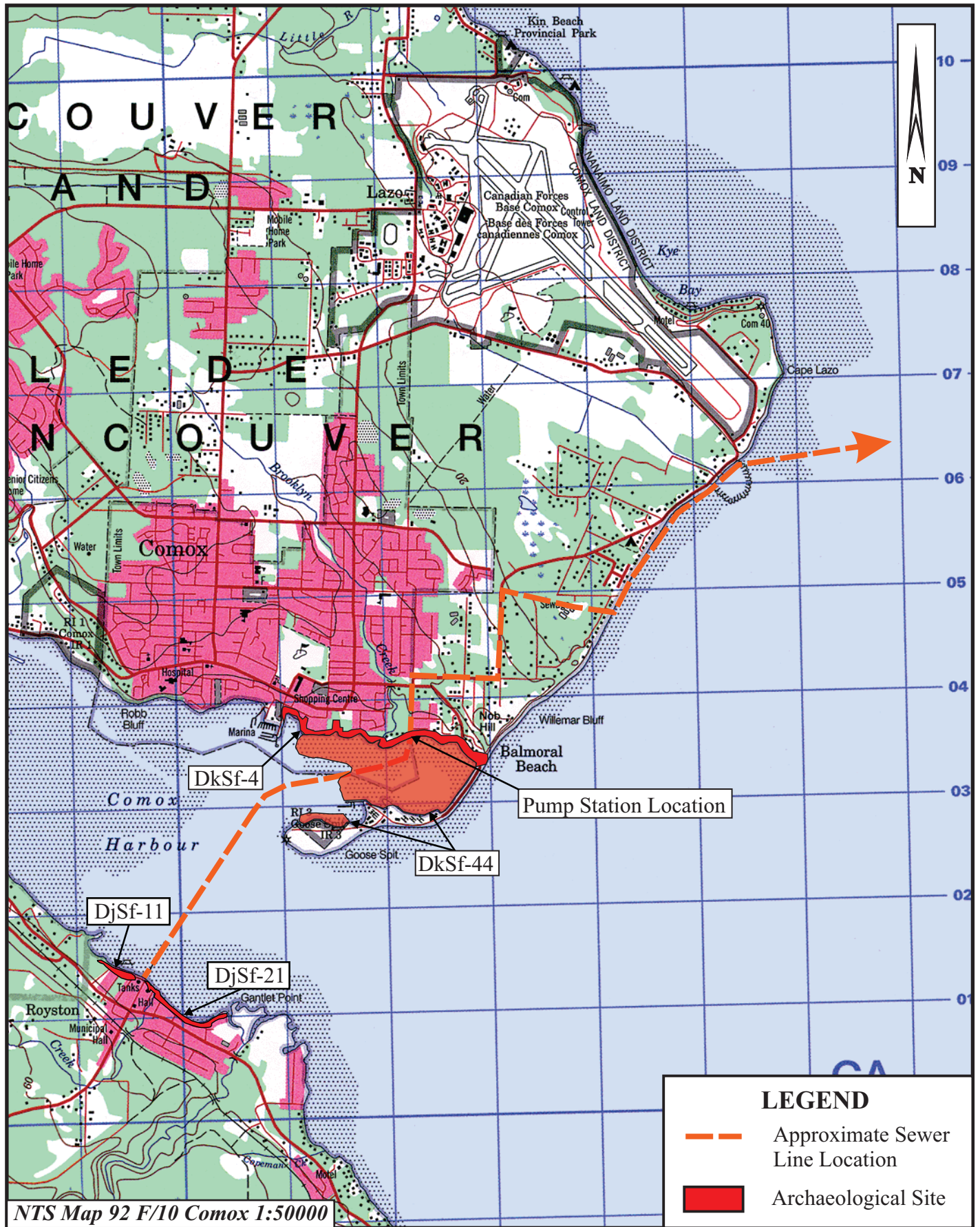

**Figure 1. Location of Archaeological Sites and Development Area**



## **Project Area**

---

The study area commences in Royston, crosses Comox Harbour and proceeds to the CVWPCC before entering the intertidal area past Curtis Road and to Cape Lazo (*Figure 1*). The study area is located along existing roads and within tidal and intertidal areas. The overall area has been significantly altered by historic as well as more recent municipal, commercial, industrial and residential development.

The project area is situated within the Eastern Variant of the very dry Maritime subsection of the Coastal Western Hemlock zone (CWHxm1), as defined by the Ministry of Forests Research Branch (1992).

## **Archaeological Background of the Study Area**

---

Prior to the PFR, an overview assessment was conducted for the study area. This included a review of the Remote Access to Archaeological Data (RAAD) website, which indicated the proposed project is in direct conflict with three previously recorded archaeological sites. At Royston, the project will likely conflict with one of the two archaeological sites in the immediate area. The following is a brief description and summary of previous information on each site.

### **Royston:**

**DjSf-11:** The archaeological site consists of shell midden, human remains, and faunal remains, as well as various artifacts and features. Located along the shoreline in Royston, the site extends from south of the 'Royston Wrecks', to between Warren Avenue and Royston Road, along Marine Drive (*Figure 2*). **DjSf-11**, originally recorded in 1963, has been subject to numerous archaeological studies and site visits since its initial recording. Several site visits have indicated much of the site has been previously altered by historic activities, as well as residential development. Portions of the site are believed to remain undisturbed, but the majority of the area within the site has not been tested.

### **OR**

**DjSf-21:** The archaeological site consists of an extensive shell midden deposit. It runs parallel to the shoreline and Marine Drive for approximately 1 km (*Figure 2*). Previous archaeological studies of the site indicate that it has been heavily disturbed by residential developments. It was also noted that much of the site has been overlain with fill material and rip rap, in order to accommodate parking lots and road ways near the shoreline. The site inventory form notes that remedial excavations in 2001 and 2010 were undertaken, which resulted in the removal of surface materials down to bedrock; the site boundary was amended to exclude the removed portion of the site.

## Comox Harbour:

**DkSf-44:** The archaeological site encompasses much of the intertidal area enclosed by Goose Spit. The site is delineated by the shoreline and primarily intertidal area as opposed to the specific archaeological features which are present within the site. The site was divided into two separate polygons to remove a subtidal area at the HMCS Quadra dock. The features include the remains of wooden weir stakes which were used to create numerous fish trap complexes within the area (*Figure 3*).

## Comox:

**DkSf-4:** The archaeological site is located along the shoreline running from the Comox Marina to Goose Spit (*Figure 3*). The site is a shell midden from which artifacts, faunal remains and human remains have been recovered. At the base of Croteau Road, the site is recorded as being approximately 40 m in width.

The development area was subject to an AIA in 1993 (Permit 1993-0038) when the property between Croteau Road and Mack Laing Nature Park was being considered for a housing development (Brolly, 1993) and prior to its establishment as MacDonald Wood Park. The assessment noted the historic disturbances through the area but found a significant portion of the site remains intact, with the largest deposits being in closer proximity to Brooklyn Creek and becoming smaller to the east at Croteau Road. The intact deposits are primarily located on the edge of a raised beach terrace, with the midden deposits at the base of Croteau Road being assessed as having a low significance.

## Expected Site Types

---

An archaeological site is defined as a location containing physical evidence of past human activity in the form of artifacts or features. For the purposes of the AOA, the potential site type categories can include, but are not limited to one or more of the following which are taken from Arcas (1998) and Golder (1999):

- **Artifact scatters:** stone artifacts (consisting of the actual tools themselves as well as the detritus from their manufacture), butchered and/or worked mammal bones. These artifacts can be located through both surface and subsurface investigations.
- **Rock art:** comprised two general types, pictographs (rock paintings), and petroglyphs (rock carvings/etchings). These are generally encountered on large rock outcroppings or large boulders. Quite often they are recorded near bodies of water.
- **Burials and associated evidence:** the material and/or features associated with mortuary practice, including human remains, and burial pits, mounds, cairns, boxes and trees, as well as grave goods and grave markers. Burial locations are commonly at village sites, but also throughout their territories for individuals who died away from village sites.

- **Shell middens:** deposits of discarded shellfish remains, fire-altered rocks, charcoal, and faunal remains (butchered mammal, bird, and fish bones) representing the locations of village sites or resource harvesting camps.
- **Habitation sites:** areas used as seasonal or permanent village sites characterized by features such as house depressions, platforms, caves and rock shelters, hearths and shell midden deposits.
- **Intertidal sites:** marine foreshore locations characterized either by artifact scatters on a beach, features constructed for beaching canoes (canoe runs), or harvesting fish (fish traps and/or fish weirs). Canoe runs are only found on shingle or rocky shores; intertidal artifact scatters are usually found on shingle beaches; stone fish traps are usually associated with shingle beaches or creek mouths, and wooden fish weirs are usually found in streams supporting runs of sea-run salmonids.

Archaeological sites are the result of certain discrete human activities occurring at a specific location on the physical landscape. Evidence for more than one type of cultural activity can take place at a single location. In mapping and recording archaeological sites, archaeologists use site boundaries to indicate the known extent of physical remains at a particular location. These boundaries are necessary to delineate the physical remains of archaeological sites to ensure their protection from proposed development activities. While boundaries are placed around archaeological sites for management purposes, it should be recognized that traditional Aboriginal use of the landscape associated with these sites may extend beyond archaeological site boundaries. Traditional use activities that leave no physical archaeological evidence, such as berry gathering, medicinal plant collecting, and spiritual practices, are more appropriately addressed through a Traditional Use Study and are not considered in this report.

## **Methodology**

---

During pedestrian traverses, the surface, as well as natural subsurface exposures were visually inspected for cultural material such as, but not limited to: intertidal cultural features, artifacts, shellfish remains, butchered animal bones, charcoal, fire cracked rock, and other indications of past evidence of human activity. Eroding bank exposures were also inspected for archaeological material from the intertidal area. The survey was extended to areas outside of the recorded boundaries of the archaeological sites, where potential for unrecorded archaeological remains existed.

## Results / Coverage

---

Archaeological material was not observed in the vicinity of the Royston development during the PFR, but shell midden was noted well removed from the project footprint. A high tide at this time precluded the opportunity to revisit **DkSf-44**. The PFR resulted in the confirmation of archaeological material at **DkSf-4** through visible surface exposures. The remainder of the project area was negative for archaeological resources and was deemed to have a low archaeological potential.

### Royston:

**DjSf-11:** Recent work on **DjSf-11** by Baseline (Permit 2015-019) has indicated that much of the site consists of heavily disturbed archaeological material. The PFR survey covered areas of the site adjacent to the shoreline; the majority of the remainder of the site is located under paved road, on private property, or under heavily vegetated areas. No archaeological exposures were identified in the vicinity of the project area (*Figure 2, Photo 1*).

**DjSf-21:** The survey encompassed the majority of the shoreline portion of the site. Only sterile material was observed in the vicinity of the project (*Figure 2, Photo 2*). The majority of the site is located under and adjacent to a paved road and residential properties. The observed positive exposure is well removed from the development area.



Photo 1: Negative exposure, DjSf-11



Photo 2: Negative exposure, DjSf-21





**Comox Harbour:**

**DkSf-44:** Due to the high tide at the time of the survey, the site could not be revisited, however Baseline personnel have visited the site during low tides previously. The fish trap complexes have been well documented and mapped by Total Station (*Figure 3, Photo 3*).



**Photo 3: Wier stakes within DkSf-44**

## **Comox:**

**DkSf-4:** Shell midden deposits from **DkSf-4** were noted near the base of Croteau Road. The area is generally low in elevation and swampy in nature with considerable previous disturbances and this portion of the site had been previously assessed as having a low significance (Brolly, 1993:9). A manhole, sewer system, Croteau Road and a boardwalk are all present within the site boundary (*Figure 3*).

No midden deposits were noted on the raised beach terrace however at the time of the field visit the ground was generally not visible due to the leaf and litter mat.

## **Croteau – Lazo:**

The field visit include vehicular and pedestrian traverses of Croteau, Lazo, Brent and Curtis Roads.

The field visit was initiated at Curtis Road where the existing outflow is located below a beach access road (*Photo 4*). Additionally, the beach access at the end of Brent Road was subject to pedestrian survey as well as a portion of the beachfront. Ample exposures along these access roads and beach cut banks yielded sterile sand deposits.

The gated portion of Brent Road was pedestrian traversed, from the CVWPCC to Curtis Road. A recently installed gas line within the road edge also provided ample exposures of sterile sand deposits.

Brent and Lazo Road area were considered to have a low potential for archaeological remains due to their inland locations.

The majority of Croteau Road was also considered to have a low potential for archaeological remains. At the time of the field visit, excavations around an existing manhole was occurring at the junction of Croteau and Midden Road. The excavation revealed sterile silts and clay.



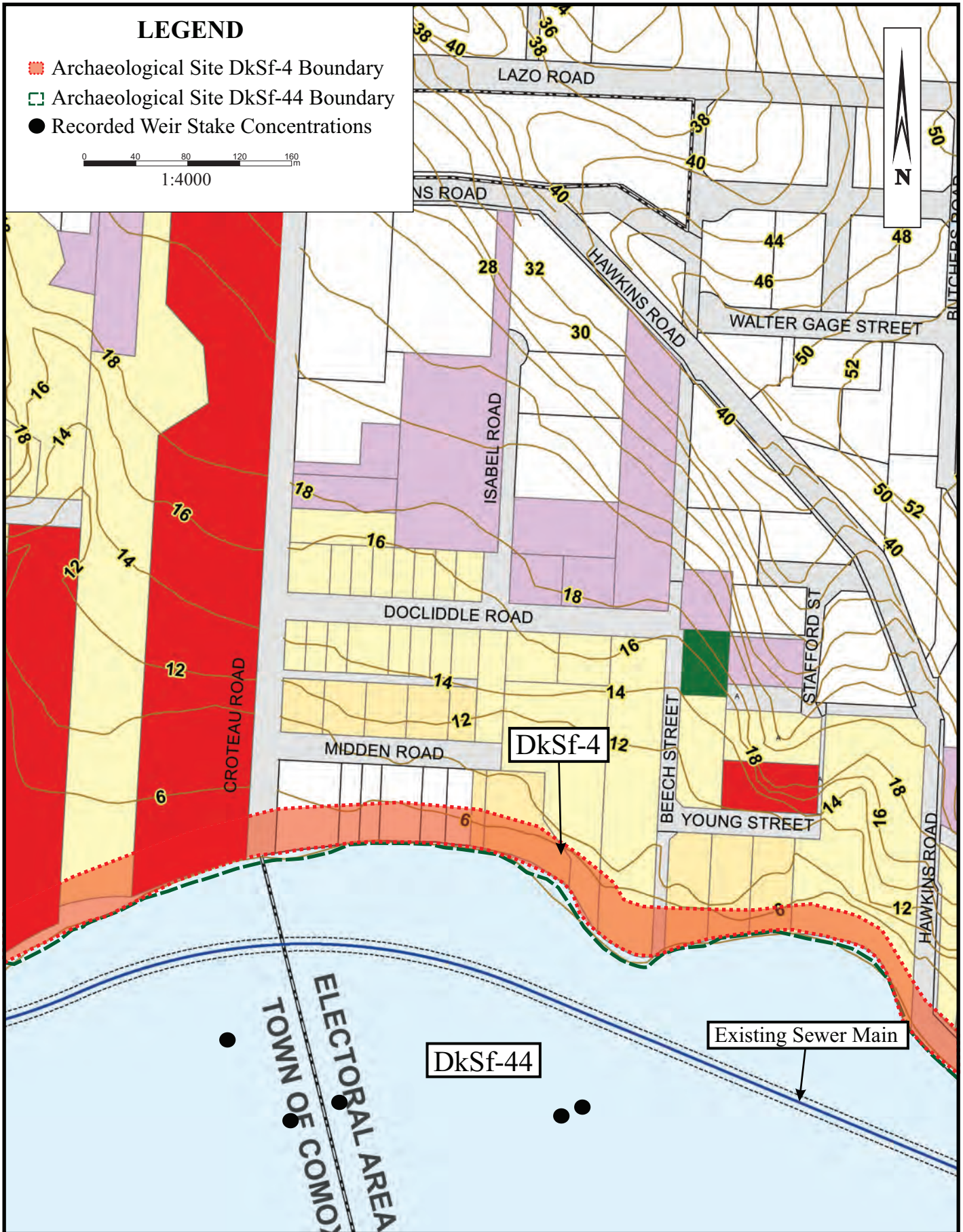

Figure 3. Location of Comox and Comox Harbour Sites



**Photo 4. Outflow pipe location off Curtis Road**

## **Impact Assessment**

---

Upon completion of the AOA and PFR, it was determined that three archaeological sites identified by the AOA are in conflict with the proposed development and will be subject to impacts. Site specific impacts are as follows:

### **Royston:**

**DjSf-11 or DjSf-21:** Impacts to the archaeological site include the trenching and the installation of effluent line from a proposed terrestrial pipe into the intertidal and tidal areas to cross Comox Harbour. These developments are likely to occur within sterile materials or previously disturbed shell midden. There is a limited potential for intact deposits being present within the development area footprint.

### **Comox Harbour:**

**DkSf-44:** Impacts to the site would include trenching and the installation of effluent line within the archaeological site boundary. As the location has yet to be determined, it is unknown if fish weir stakes will be impacted.

### **Comox:**

**DkSf-4:** Impacts will include trenching, the installation of effluent line and the construction of a pump station. The development will likely impact a combination of previously disturbed and potential intact archaeological deposits. The intact deposits would be potentially located on the upper beach terrace.

### **Croteau – Lazo:**

No impacts to known archaeological sites are anticipated from the boundary of **DkSf-4** to the Cape Lazo outflow.

## **Recommendations**

---

It is recommended that the project proceed under a Section 12, Site Alteration Permit (SAP) issued by the BC Archaeology Branch under the authority of the *HCA*.

### **Royston:**

**DjSf-21 or DjSf-11:** The history of urbanization of the area has resulted in the identification of primarily previously disturbed archaeological remains or areas completely void of archaeological material. Based on the location of the development, it is recommended that the site be managed under a SAP with archaeological monitoring.

### **Comox Harbour:**

**DkSf-44:** A SAP will be required for development within the archaeological site boundary. If weir stakes are to be impacted, a mitigative plan will be developed in consultation with the BC Archaeology Branch. This may involve the radiocarbon dating of impacted weir stakes and appropriate storage of the features.

**Comox:**

**DkSf-4:** The previous developments (CVWPCC sewer system and Croteau Road) within the vicinity of the proposed pump station, effluent line and sewer main have caused significant disturbances to portions of the archaeological material, with the potential for intact archaeological remains being present on the raised beach terrace. The proposed developments can be managed under a SAP with a condition of archaeological monitoring as well as a testing methodology in advance of the construction for potentially intact deposits.

**Croteau/Midden Road Junction to the Cape Lazo outflow:**

Based on the absence of previously recorded archaeological remains and the assessed low archaeological potential, no further archaeological work is recommended for this portion of the project.

**Table 1. Summary of Recommendations**

<b>Location</b>	<b>Archaeological Sites</b>	<b>Recommendation</b>
Royston	<b>DjSf-11</b> <b>DjSf-21</b>	Section 12, Site Alteration / Monitoring
Comox Harbour	<b>DkSf-44</b>	Section 12, Site Alteration, mitigate weir stakes if impacted
Comox	<b>DkSf-4</b>	Section 12, Site Alteration / Monitoring / Possible testing in advance of alterations
Croteau/Midden Road junctions to Cape Lazo outflow	<b>N/A</b>	No further work

**SAP Recommendations:**

As per the concurrent archaeological studies/description section of the SAP Application (Section 4), mechanical operations within the archaeological site boundaries will be monitored by a qualified archaeologist. In the event that potentially intact remains are encountered, a subsurface testing program can be employed to determine the nature, composition and integrity of the deposits. Where the deposits are determined to be minimal or previously disturbed, mechanical operations may resume. Generally, mechanical excavation of archaeological material is conducted in 5-10 cm increments, with back dirt being screened or raked depending on the content of the material.

Where significant intact archaeological deposits are encountered, a mitigative program of systematic data recovery (SDR) may be employed. This would involve the excavation of 1x1 m units in controlled levels. The amount of SDR would depend on the site content with all archaeological features being hand excavated. In general, a minimum of 1 m of

hand excavations are required for every 10 m<sup>2</sup> of midden being impacted. When mechanical excavations within intact archaeological sites continue, they will be limited to scraping deposits in <5 cm increments to allow for the identification of archaeological features, including human burials.

**General Recommendations:**

Developers and operators should be aware of the potential of undiscovered archaeological remains in any surveyed or unsurveyed areas which are protected under the *Heritage Conservation Act*. If previously unrecorded archaeological remains are identified, all development activities in the vicinity of archaeological remains must be halted as not to threaten these remains and to immediately notify the BC Archaeology Branch (Ministry of Forests, Lands, and Natural Resource Operations).



## Reference List

---

Apland, B. and R. Kenny

1998 *British Columbia Impact Assessment Guidelines*. Revised Edition. BC Archaeology Branch, Victoria, BC.

Arcas Consulting Archaeologists Ltd.

1998 *GIS Modeling of Archaeological Potential for the Northern Nuu-chah-nulth Hahoulthees, 1998*. On file with the BC Archaeology Branch, Ministry of Forests, Lands and Natural Resource Operations.

Brolly, Richard

1993 *Archaeological Impact Assessment of Lot 20, D.L. 87 Comox, BC*. Permit 1993-0038. On file with the BC Archaeology Branch, Ministry of Forests, Lands and Natural Resource Operations.

Golder Associates Ltd.

1999 *Report on an Archaeological Overview of the Central Coast LRMP Area*. On file with the BC Archaeology Branch, Ministry of Forests, Lands and Natural Resource Operations.

Province of British Columbia

1992 *Biogeoclimatic Zones of British Columbia*. Ministry of Forests, Victoria BC.

## **APPENDIX B – ENVIRONMENTAL REPORT (TO COME)**



## **APPENDIX C – GEOTECHNICAL INVESTIGATION REPORT (TO COME)**

## **APPENDIX D – SAMPLE GENERAL ARRANGEMENT AND PROCESS DRAWINGS (DRAFT)**

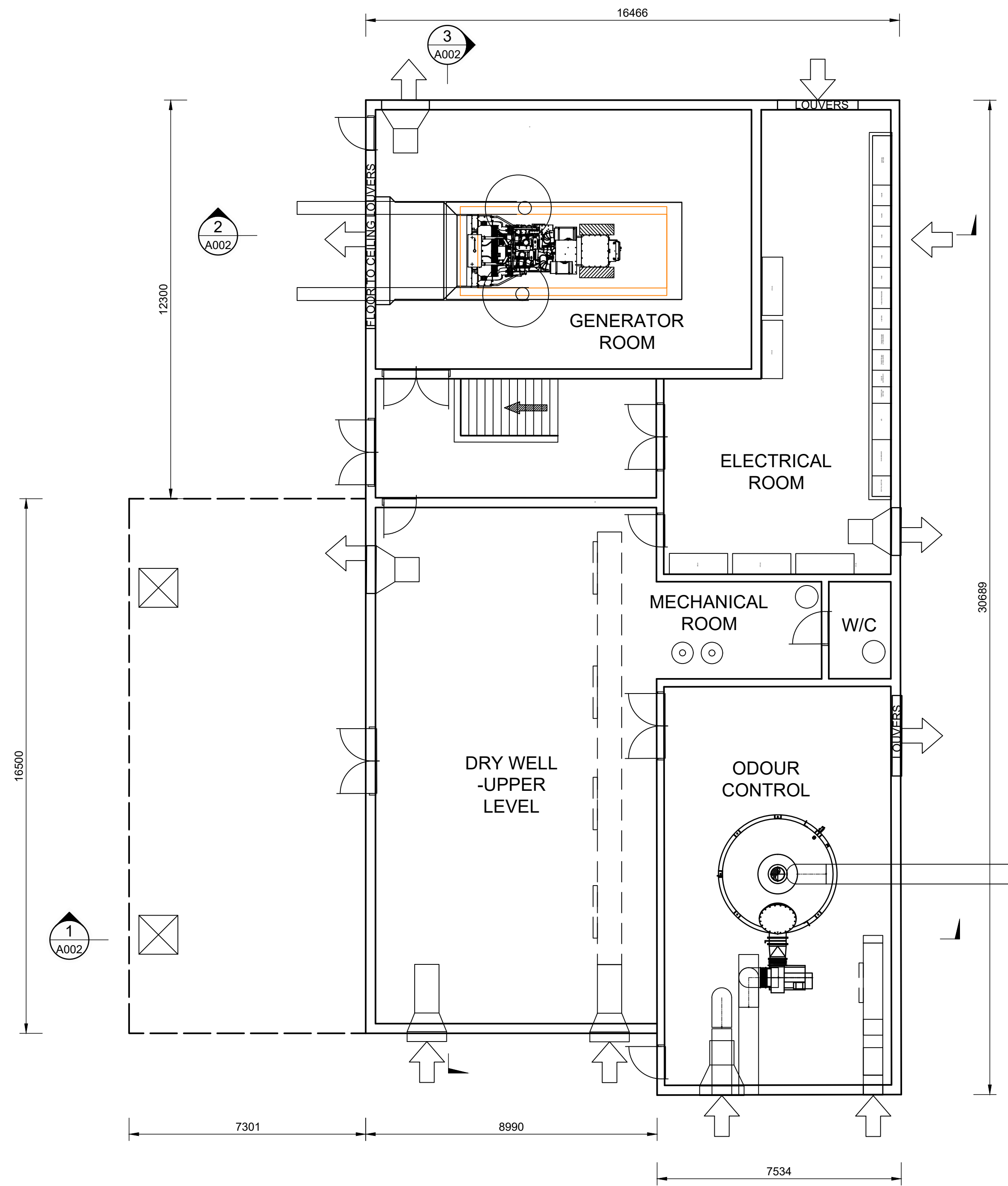
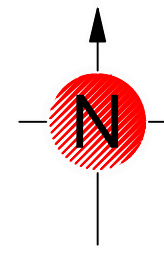

**UPPER LEVEL PLAN**  
Scale: 1:100

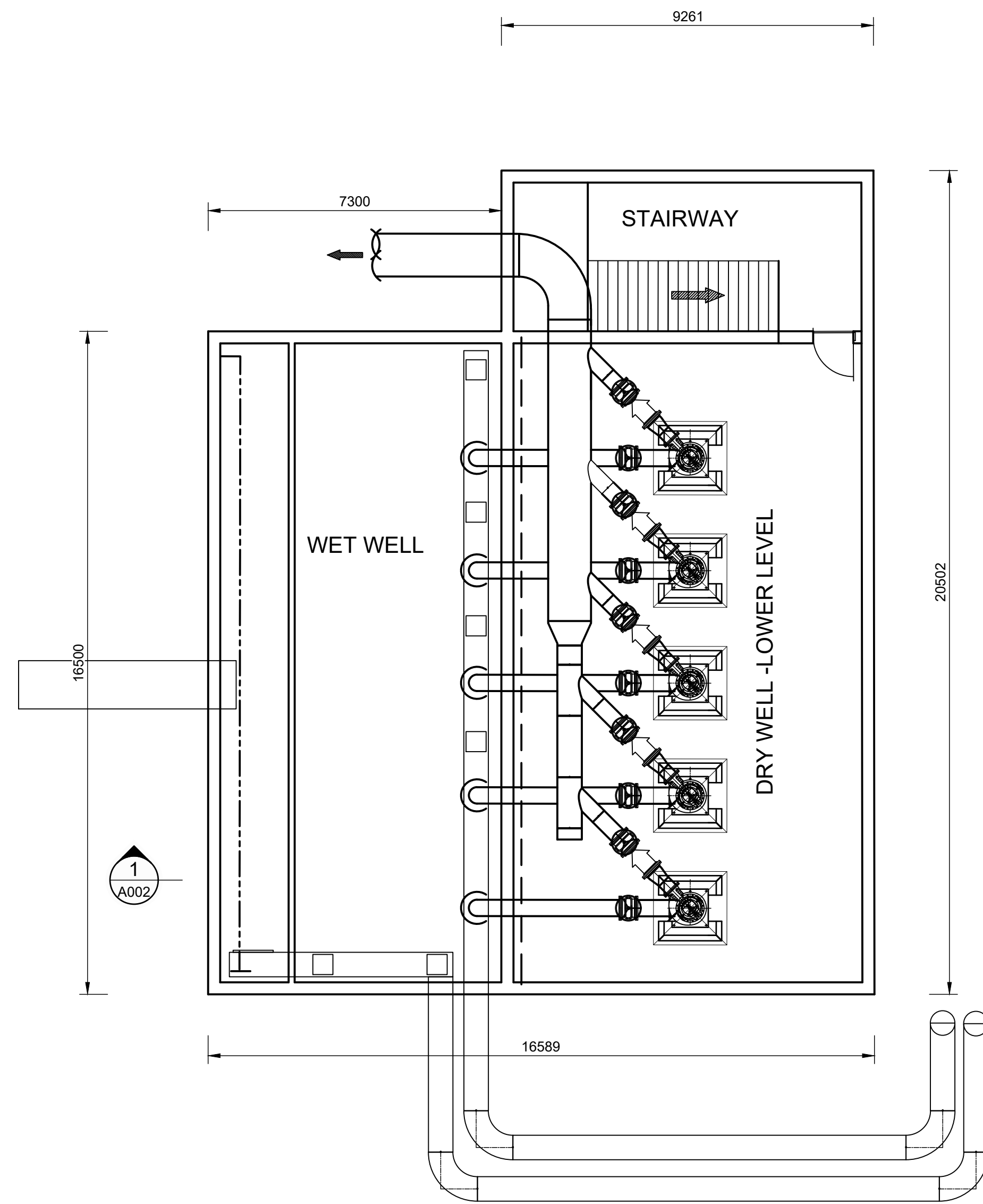

**LOWER LEVEL PLAN**  
Scale: 1:100

**LEGEND**  
➔ AIR FLOW DIRECTION

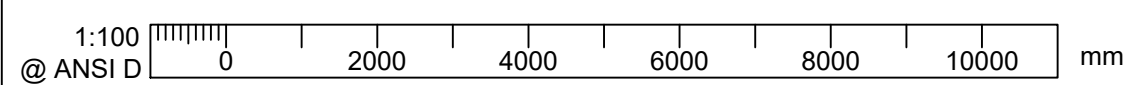

Revision	Amendment	Approved	Revision Date

**OPUS**  
North Vancouver Office  
604-990-4800

210-889 Harbourside Drive  
North Vancouver BC  
V7P 3S1, Canada

Designed	Approved	Approved Date
Drawn	Scales	

Project COMOX VALLEY REGIONAL DISTRICT WATER SUPPLY UPGRADES PROPOSED PUMPSTATION	
Sheet <b>PLAN VIEWS</b>	
Project No. D-13125.00	Sheet No. / Revision A001 / #####

300 mm  
200  
100  
50  
0  
10 mm

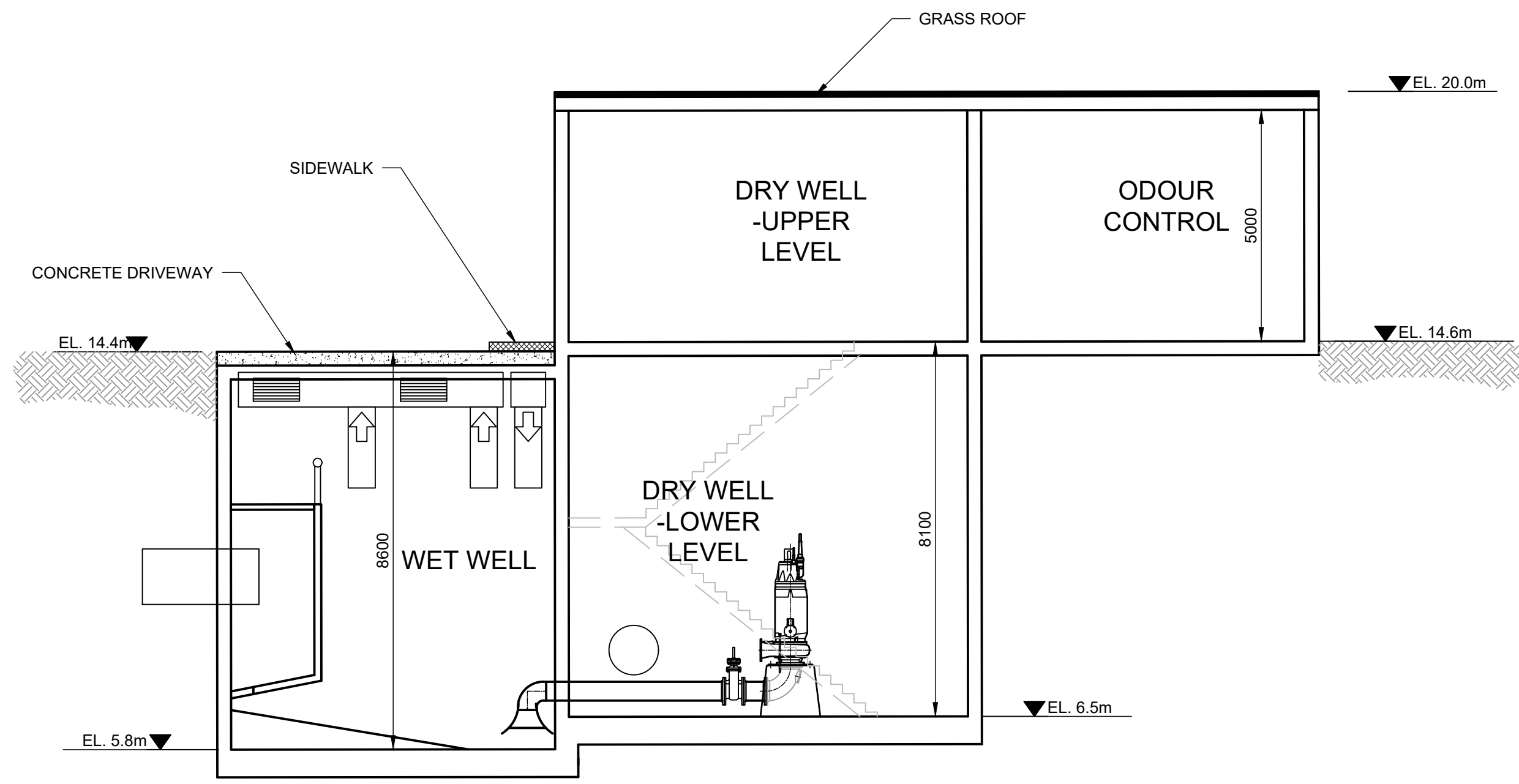

SECTION 1  
Scale: 1:100  
A001

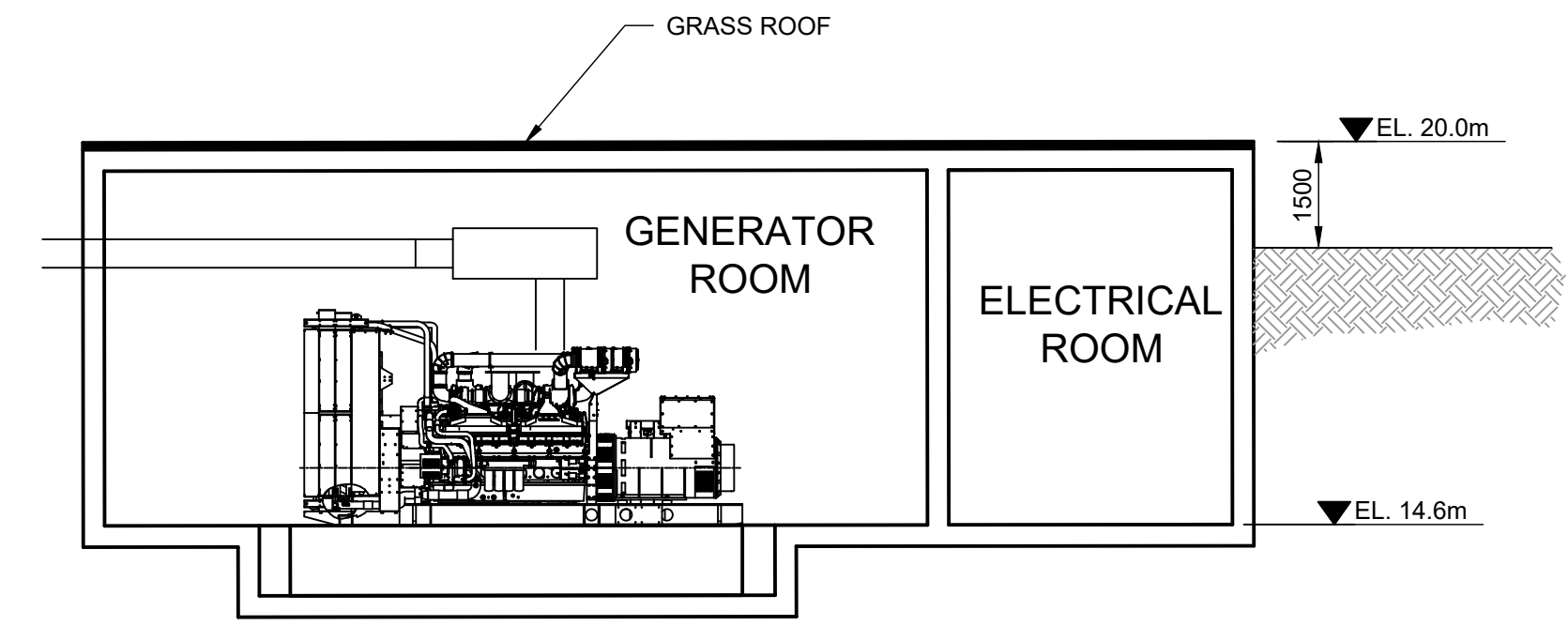

SECTION 2  
Scale: 1:100  
A001

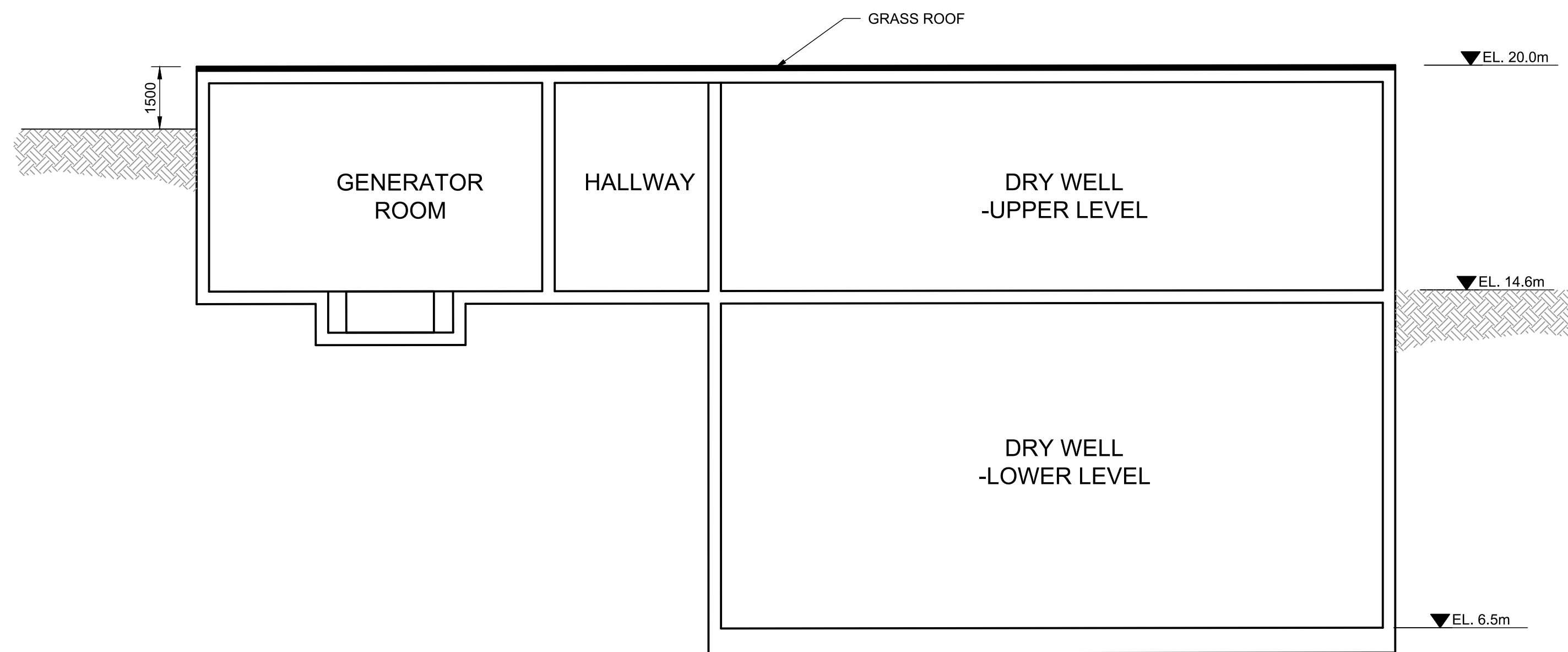

SECTION 3  
Scale: 1:100  
A001

1:100  
0 2000 4000 6000 8000 10000 mm

Revision	Amendment	Approved	Revision Date

**OPUS**  
North Vancouver Office  
604-990-4800

210-889 Harbourside Drive  
North Vancouver BC  
V7P 3S1, Canada

Designed	Approved	Approved Date
Drawn	Scales	

Project COMOX VALLEY REGIONAL DISTRICT WATER SUPPLY UPGRADES PROPOSED PUMPSTATION	
Sheet SECTIONS	
Project No. D-13125.00	Sheet No. Revision A002 #####



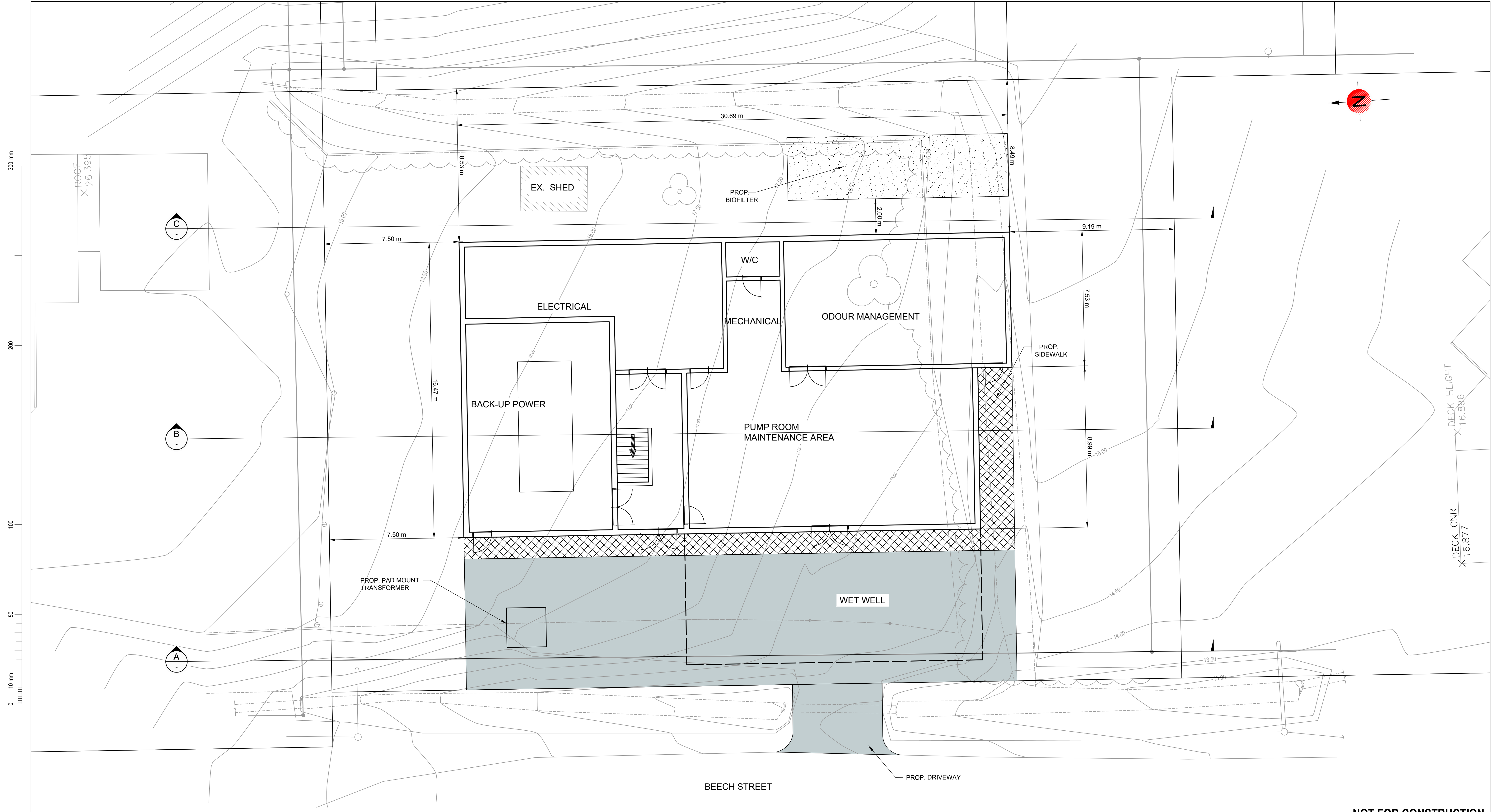

300 mm  
200  
100  
50  
0 10 mm

**NOT FOR CONSTRUCTION**

- NOTE:
1. PROPOSED NO.2 PS BUILDING ELEVATION 14.6m
  2. PROPOSED DRIVEWAY ELEVATION 14.4m

Revision	Amendment	Approved	Revision Date
A	ISSUED FOR INFORMATION	WB	20/04/2017

**OPUS**  
North Vancouver Office  
604-990-4800

210-889 Harbourside Drive  
North Vancouver BC  
V7P 3S1, Canada

Designed	Approved	Approved Date
WB		20/04/2017
Drawn	Scales	
K.BEHNKA	1:100	

Project	
COMOX VALLEY REGIONAL DISTRICT COMOX No. 2 PUMP STATION NEW WASTEWATER LIFT STATION	
Sheet	
SITE LAYOUT	
Project No.	Sheet No. / Revision
D-13125.00	C100 / A

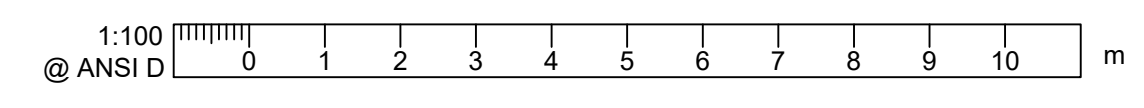

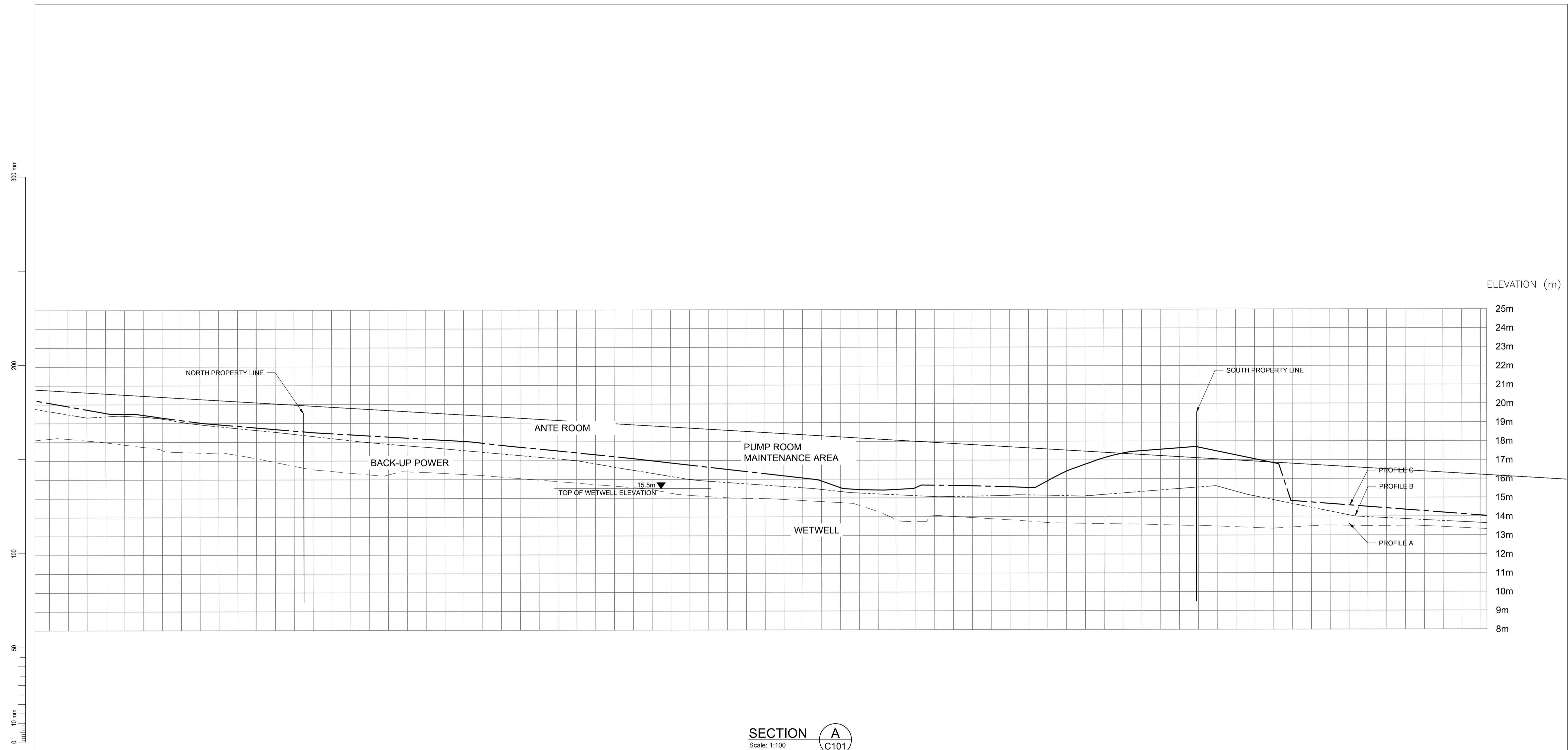

**SECTION A**  
Scale: 1:100

**NOT FOR CONSTRUCTION**

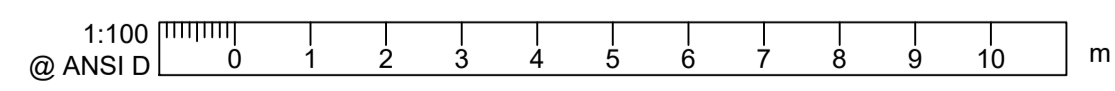

Revision	Amendment	Approved	Revision Date
A	ISSUED FOR INFORMATION	WB	20/04/2017

**OPUS**  
North Vancouver Office  
604-990-4800

210-889 Harbourside Drive  
North Vancouver BC  
V7P 3S1, Canada

Designed	Approved	Approved Date
WB		20/04/2017
Drawn	Scales	
K.BEHNKA	1:100	

Project	
COMOX VALLEY REGIONAL DISTRICT	
BUILDING PROFILE	
Sheet	
<b>SECTION A</b>	
Project No.	Sheet No.
D-13125.00	C101
Revision	A

300 mm  
200  
100  
50  
10 mm  
0

SECTION **B**  
Scale: 1:50  
C102

**NOT FOR CONSTRUCTION**

Revision	Amendment	Approved	Revision Date
A			??

 **OPUS**  
North Vancouver Office  
604-990-4800

210-889 Harbourside Drive  
North Vancouver BC  
V7P 3S1, Canada

Designed	Approved	Approved Date
		??

Drawn	Scales
K.BEHNKA	1:50

Project	Sheet No	Revision
COMOX VALLEY REGIONAL DISTRICT		
BUILDING PROFILE		
SECTION B		
Project No. D-13125.00	C102	A

1:50 @ ANSI D 0 1000 2000 3000 4000 5000 mm





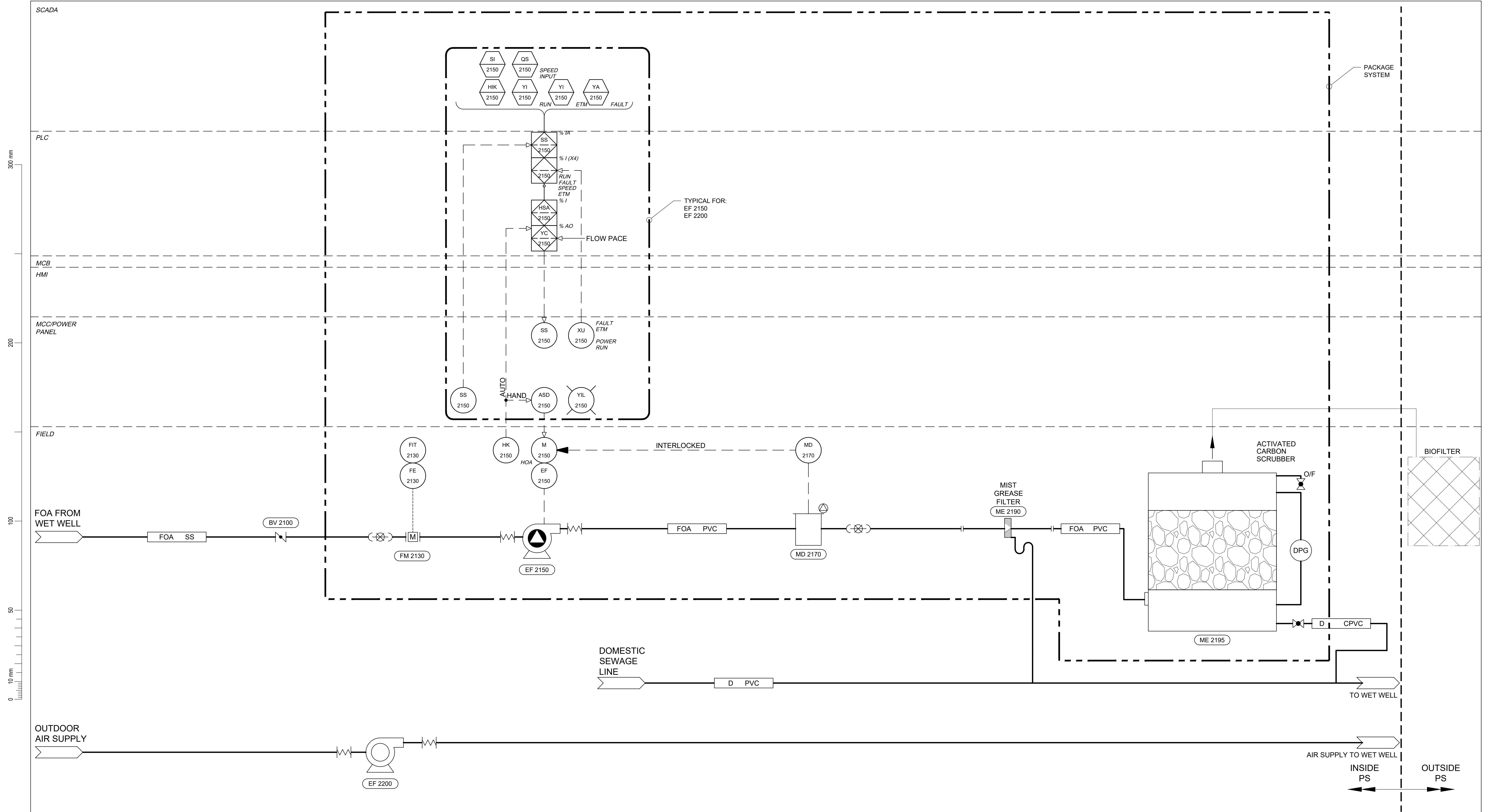

30 mm  
200  
100  
50  
10 mm

1:25  
@ ANSI D 0 400 800 1200 1600 2000 2400 mm

Revision	Amendment	Approved	Revision Date

**OPUS**  
North Vancouver Office  
604-990-4800

210-889 Harbourside Drive  
North Vancouver BC  
V7P 3S1, Canada

Designed	Approved	Approved Date
Drawn	Scales	
JV	NTS	

Project  
COMOX VALLEY REGIONAL DISTRICT  
COMOX No. 2 PUMP STATION  
NEW WASTEWATER LIFT STATION

Sheet  
**PROCESS FLOW DIAGRAM**  
ODOUR CONTROL

Project No.	Sheet No.	Revision
D-13125.00	P101	

## **APPENDIX E – TOPOGRAPHIC SURVEY OF PUMP STATION PROPERTY (TO COME)**

## **APPENDIX F – TOPOGRAPHIC SURVEY OF PIPE ALIGNMENT (TO COME)**

## **APPENDIX G – BC ONE CALL SUBMITTAL RESPONSES**



Power smart

**Underground Locates**

BC 1 Call: 1-800-474-6886

BC Hydro: 1-866-960-3740

BC Hydro Fax: 1-866-844-3498

BC Hydro email: [bchlocates@bchydro.com](mailto:bchlocates@bchydro.com)

**Location of B.C. Hydro's Electrical System**

The attached drawing shows the location of our electrical distribution system near your location request. Our database, to the best of our knowledge, shows that there is overhead service.







Please note, BC Hydro does not have any record of any private property subfeeds beyond the point of original connection. Please contact a private locator on electrical subfeeds.

**PLEASE DIG CAREFULLY AND SAFELY!**

If you have any questions, please call our office at 1-866-960-3740 Monday to Friday 8:00am to 4:00pm.

Please note: Our legend is dynamic and only displays underground electrical if it exists in the provided schematic.

The following attributes are above ground assets and are not included in the legend.

	Service Location - Existing Location
	Pole - Existing Joint Use Location
	Transmission - Structure Location
	Transmission - Pole Location
	Transmission - Clamp Location
	Transmission - Overhead Line



Ticket No: 2017232506

Name: LEAN LAURON  
 Company: OPUS INTERNATIONAL CONSULTANTS LTD.

2017-06-09

Street No. From:  
 Street No. To:  
 Street: \*\*\* SEE ADD'L DIG IN FAX No.:  
 City: COMOX VALLEY DISTRICT

Phone No.: 2508684925  
 Email: lean.lauron@opus.co

Scale: 1:2500

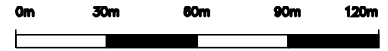

**DETERMINING THE LOCATION OF UNDERGROUND OR EMBEDDED CONDUIT AND CONDUCTOR ON PRIVATE PROPERTY IS THE SOLE RESPONSIBILITY OF THE PROPERTY OWNER**

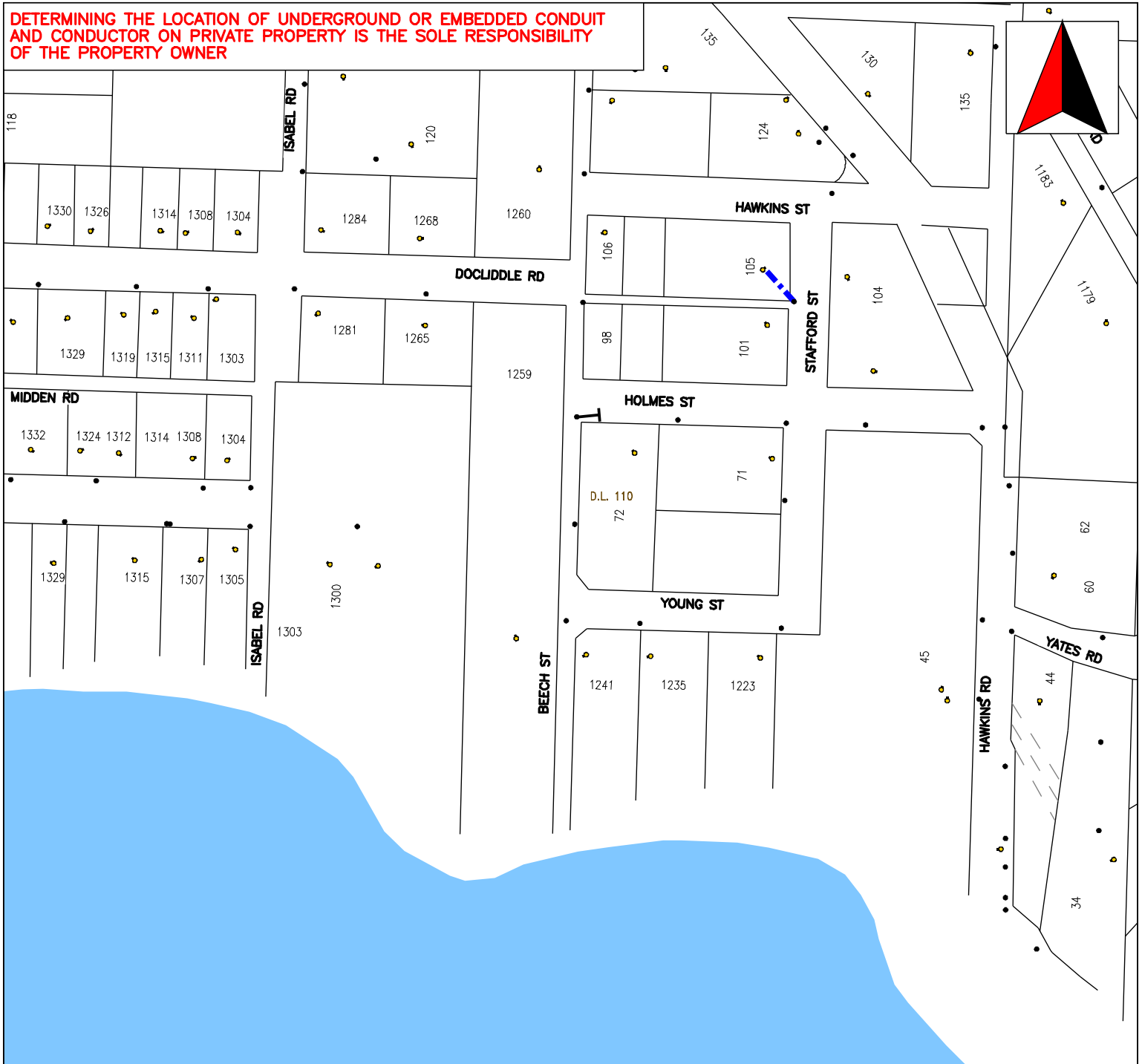

**THIS PRINT IS PROVIDED FOR GENERAL INFORMATION ONLY**

BC Hydro does not accept any responsibility for errors or omissions. The information provided is the most accurate information we have available. Beware that underground electrical systems may exist that have not been record "AS CONSTRUCTED" yet.

The onus is on the operator to hand dig to locate the actual underground utility before any mechanized digging proceeds.

**Legend**

- distribution underground [Gis]
- U/G Secondary

## Gas line location information

Please find attached the gas line location information you requested from FortisBC through BC ONE CALL.

This package includes:

1. **Instructions** - safe excavation
2. **Instructions** - if you hit a gas line
3. **Safety and permit information** from FortisBC
4. **Provincial gas safety regulations** and occupational health & safety regulations

In addition, you will also have:

- Your **gas line location map(s)** that show the location of gas lines in the area(s) where you've indicated you'll be digging
- Your **service drawing** of where the gas service line(s) can be found in the area you'll be digging
- A letter that introduces a **new icon** that appears on the location map(s) to show active gas lines

You can also visit our website for more information at [fortisbc.com/digsafe](https://fortisbc.com/digsafe).

If the information provided on your BC ONE CALL ticket does not correspond to the area in which you intend to work, as shown in the attached maps and service drawing, please call FortisBC at **1-888-822-6555**.

**To protect your safety and keep a safe worksite: please review all the items contained in this information package, including the important safety instructions on the following page, *BEFORE* you begin work.**

## 1. When excavating, you must:

- Keep gas line location information on-site at all times, and use to locate and mark lines with paint or stakes.
- Hand dig first to expose the line at several locations to determine its exact location and depth before using any mechanical equipment.
- Follow all provincial laws including WCB regulations for excavating near buried utilities.
- If you have hand exposed within 1 metre on either side of where the indicated gas line should be and you still cannot locate the gas line, OR if you have difficulties reading or understanding our location information, call FortisBC at **1-888-822-6555**.

*This illustration shows how to safely hand dig first to expose the natural gas line.*

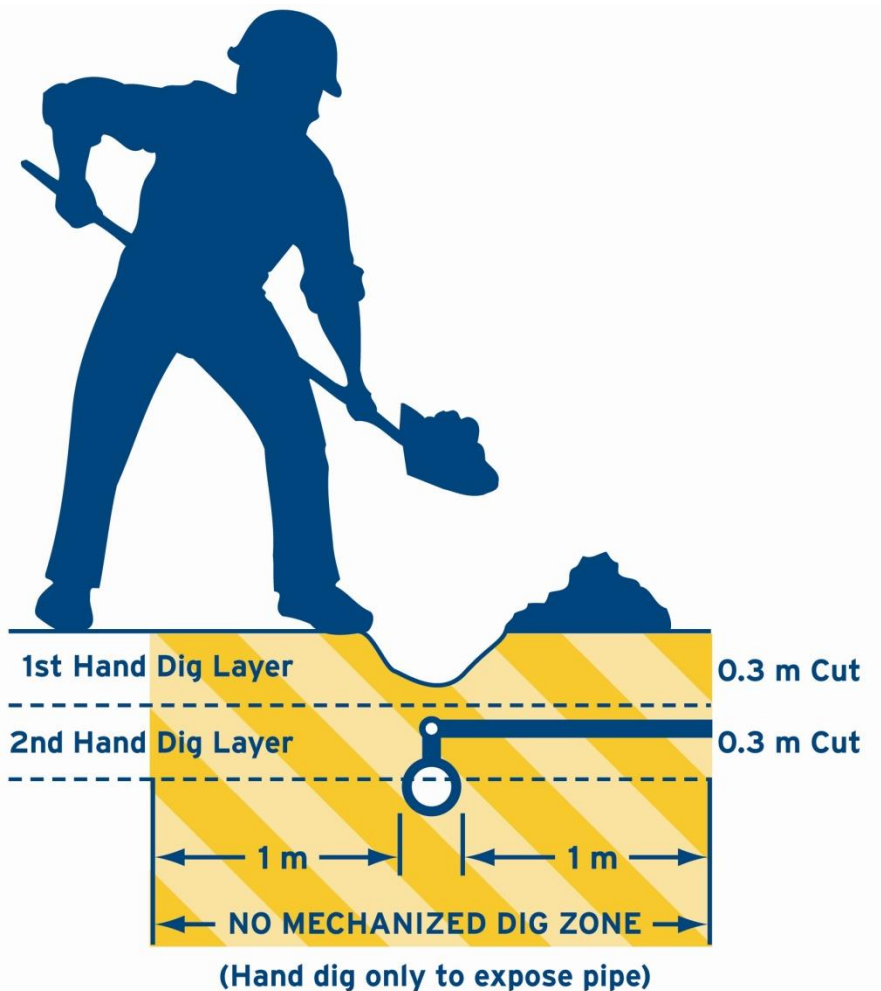

## 2. What to do if you hit a gas line

- Shut off all sources of ignition, including lit cigarettes, flares, welding torches, cell phones, power tools and equipment.
- Do not operate electrical switches — even the toggle on a light switch can generate a spark.
- Clear the area of all people.
- Stop all engines and motors.
- **Immediately call FortisBC's 24 hour emergency line at 1-800-663-9911.**

If there is danger of fire, call 911 or the fire department.

If the pipe break or the leak is underground, warn people in nearby buildings. If the possibility exists that leaking natural gas is migrating into neighbouring buildings via sewer lines and drains, evacuate all occupants immediately.

## What *not* to do if you hit a gas line

- Never attempt to make temporary repairs to a damaged gas line yourself.
- Never backfill over ruptured or damaged gas pipes.
- Do not operate any gas valves unless instructed to do so by FortisBC.

**Always call the FortisBC emergency line at 1-800-663-9911 if you damage a gas line.**

## 3. The following outlines when you need a permit or have other requirements.

### FortisBC permit

In some cases a permit is required when working around FortisBC facilities. A permit is **required** before digging when your work is:

- within **10 metres** of a **Transmission Pressure (TP)** pipeline within a public or private right of way (e.g., road allowance)
- within **2 metres** of an **Intermediate Pressure (IP)** pipeline within a public or private right of way (e.g., road allowance)
- is within a FortisBC pipeline **right of way**

### To obtain a permit:

- Call the **FortisBC Permit Desk** at **604-576-7021** or **1-877-599-0996**.
- Email your questions to **property.services@fortisbc.com**.
- Visit **fortisbc.com/rightofway**.

You may proceed with your work and a permit is **not required** when your activity takes place:

- in the area of **Distribution Pressure (DP)** gas mains
- between **30 metres and 10 metres** from an **Intermediate Pressure (IP)** pipeline

### Written permission

Within **30 metres** of a **Transmission Pressure (TP)** pipeline, you must not proceed with the activity until you have been contacted by FortisBC and obtained written permission for the activity from FortisBC.

## Onsite location

**Between 10 metres and 2 metres** from an **Intermediate Pressure (IP)** pipeline, you must call the FortisBC Public Underground Location Services Department at 1-888-822-6555 to request an on-site pipeline locate.

## Inspection

An inspection may be required if your site work or activity is within 2 metres adjacent to, over, or crossing a distribution pressure (DP) gas main with a diameter of 273mm (10 inches) or greater. Please call **604-576-7212** to arrange for an inspector prior to commencing work.

## Delayed work

If your activity is delayed and your excavation work has not started within 10 working days of receiving gas line location information from FortisBC, you must verify the location information through BC ONE CALL at **1-800-474-6886** before commencing the activity. The gas supply system changes constantly and line-location records can quickly become dated.

## Blasting (for contractors only)

Section 41 of the Gas Safety Regulation governs the requirements for blasting in the vicinity of gas installations. The blasting notification period does not start until after a blasting plan has been provided to FortisBC. A blasting plan must be submitted by the contractor's blasting engineer and contain the following information:

- blasting location relative to FortisBC facilities
- type and size of the charge and its delay
- declaration the blasting plan is based on the utility information provided, local ground concerns and theory
- confirmation that the blasting will not damage the utility

## Other provincial regulations to follow

The following regulations and procedures must be followed by everyone who plans to excavate around buried utilities. For complete safety regulations, visit the websites listed below.

### The Gas Safety Regulation:

[www.bclaws.ca/EPLibraries/bclaws\\_new/document/ID/freeside/15\\_103\\_2004](http://www.bclaws.ca/EPLibraries/bclaws_new/document/ID/freeside/15_103_2004) (effective April 1/04)

#### Procedures for a gas installation in vicinity of underground structures

**37 (1)** A person must not install a gas installation or allow one to be installed so that the gas installation passes through or interferes with any underground structure that is not solely for the use of a gas installation without the written permission of the owner of the underground structure.

#### Duties of persons intending to construct near gas installation

**38** A person who intends to construct an underground structure within one metre of a gas installation must notify the gas company operating in the area at least 3 business days before starting the excavation for the structure.

#### Procedures for excavations

**39 (2)** A person who intends to excavate must, at least 2 business days before the person intends to excavate, request from the gas company serving that area, or its agent, information on the location of all underground gas installations in the vicinity of the proposed excavation.

### **Hand digging to confirm location**

**39 (7)** The indicated location of gas installations must be confirmed by the excavator by means of hand digging and the excavator must expose the gas installations at a sufficient number of locations to determine their exact positions and depths before using mechanized excavation equipment for any purpose other than breaking the surface cover.

### **Gas installation not where indicated**

**39 (9)** If an excavator finds that the gas installation is not within the limits described by the gas company,  
**(a)** the excavator must so advise the gas company,  
**(b)** the gas company must immediately assist in locating and exposing the installation for the excavator,  
**(c)** mechanized excavation must not be carried on in the vicinity until the installation has been located and exposed.

### **No probing to locate gas installations**

**40** A person must not probe with pointed tools to locate gas installations.

### **Requirements for blasting in vicinity of gas installation**

**41 (1)** A person who intends to blast in the vicinity of a gas installation must

- (a)** comply with sections 37 to 39, and
- (b)** notify the relevant gas company at least 3 business days before blasting.

**(2)** If a person has already complied with sections 37 to 39 and discovers in the process of construction that blasting is required, the person must notify the relevant gas company at least 24 hours, counted only on business days, before blasting is to start.

## **Occupational Health & Safety Regulation:**

[www2.worksafebc.com/Publications/OHSRegulation/Home.asp](http://www2.worksafebc.com/Publications/OHSRegulation/Home.asp)

### **20.79 Underground utilities**

- (1)** Before excavating or drilling with powered tools and equipment, the location of all underground utility services in the area must be accurately determined, and any danger to workers from the services must be controlled.
- (2)** Excavation or drilling work in proximity to an underground service must be undertaken in conformity with the requirements of the owner of that utility service.
- (3)** Pointed tools must not be used to probe for underground petroleum and electrical utility services.
- (4)** Powered equipment used for excavating must be operated so as to avoid damage to underground utility services, or danger to workers.

*FortisBC Energy Inc. does business as FortisBC. The company is an indirect, wholly owned subsidiary of Fortis Inc. FortisBC uses the FortisBC name and logo under license from Fortis Inc.*





**ATTENTION:**  
 DO NOT RELY ON THIS INFORMATION ALONE!  
 You must hand dig to expose the line at several locations to determine its exact location and depth before using any mechanized equipment. All locations are approximate only. Gas lines built after the date shown, are not included in this information package. FortisBC will not accept responsibility for errors or omissions. Gas line depths are not available due to possible changes in grade. Record information provided is specific to location of original request from BC One Call. Measurements displayed in meter(s).

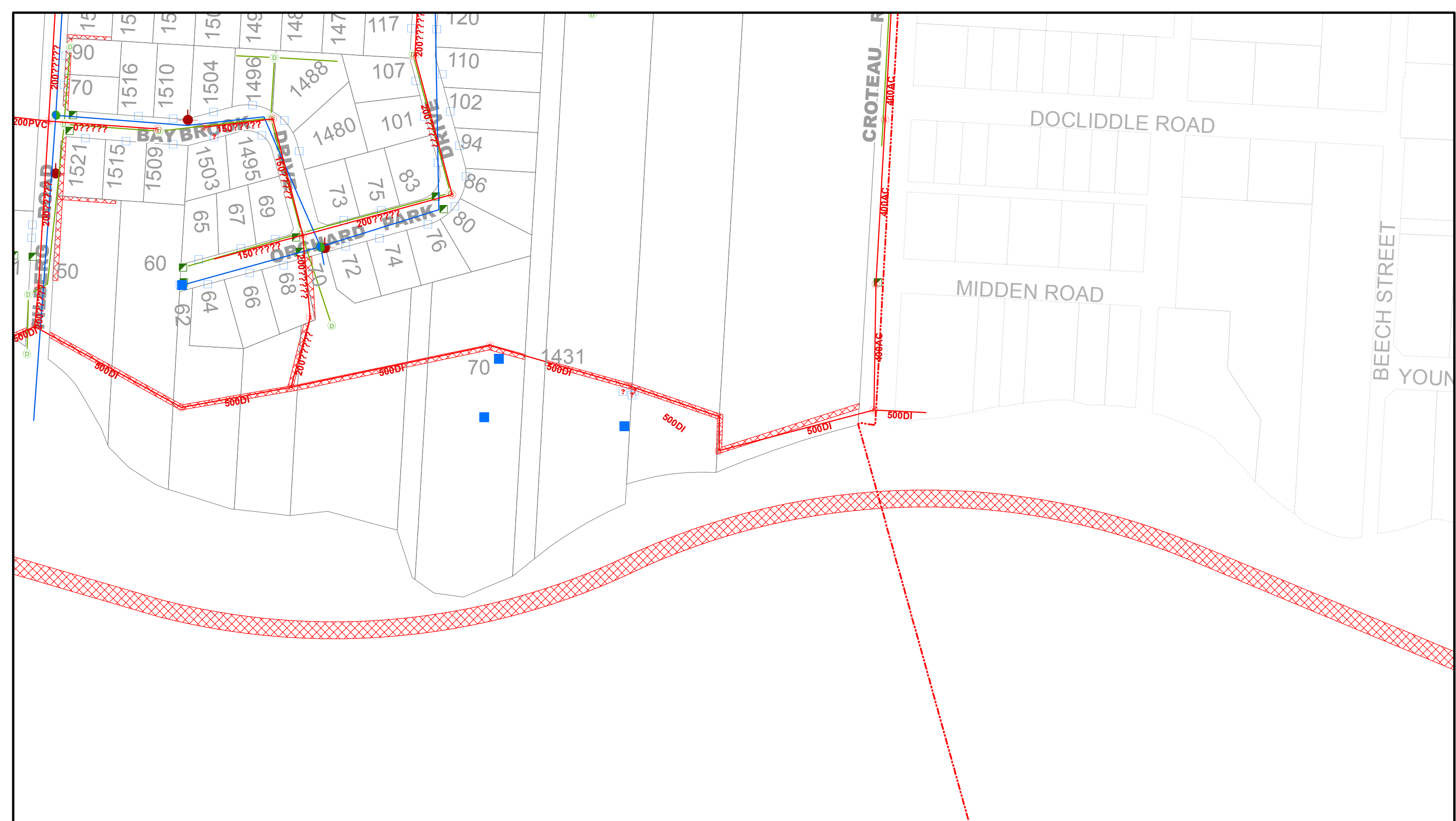

# Engineering Layers

Map 3

Sanitary Mains	Pressure Release Valves	Water Meter (to verify)	Storm Mains	Town Boundary
Sani Catch Basin	Air Release Valves	METERVAULT	Storm Catch Basin	Parcels
Sani Cleanout	Water Isolation Valves	Water meter	Storm Cleanout	Outside Town Boundary
Sani Lift Station	Water Valve - Closed	WTS WM	Storm Manhole	
Sani Manhole	Water Valve - Open	FireHydrants	Storm Outfall	
Sani Pump Station	Watervalue	Water Mains	Storm Service Cap	
Sani Service Valve	Water Blow Offs	WaterLeads	Storm Private Catch Basin	

0 50 100 150 m

NAD83 UTM 10  
Map Updated: April 19, 2017  
Map By: Mapping Dept.

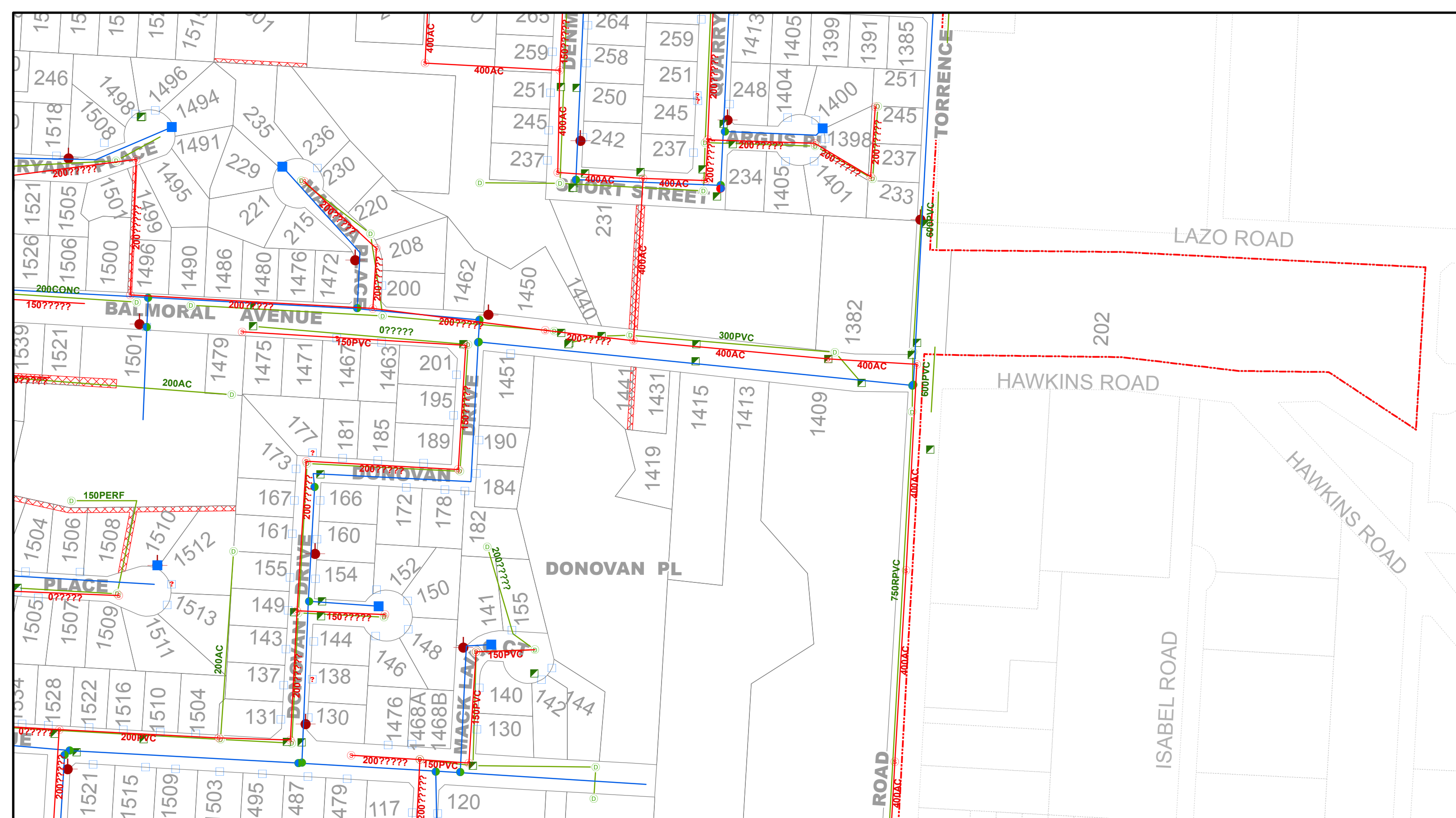

# Engineering Layers

Map 7

- |                    |                         |                         |                           |                       |
|--------------------|-------------------------|-------------------------|---------------------------|-----------------------|
| Sanitary Mains     | Pressure Release Valves | Water Meter (to verify) | Storm Mains               | Town Boundary         |
| Sani Catch Basin   | Air Release Valves      | METERVAULT              | Storm Catch Basin         | Parcels               |
| Sani Cleanout      | Water Isolation Valves  | Water meter             | Storm Cleanout            | Outside Town Boundary |
| Sani Lift Station  | Water Valve - Closed    | WTS WM                  | Storm Manhole             |                       |
| Sani Manhole       | Water Valve - Open      | Fire Hydrants           | Storm Outfall             |                       |
| Sani Pump Station  | Watervalue              | Water Mains             | Storm Service Cap         |                       |
| Sani Service Valve | Water Blow Offs         | Water Leads             | Storm Private Catch Basin |                       |

0 50 100 150 m

NAD83 UTM 10  
Map Updated: April 19, 2017  
Map By: Mapping Dept.



# Engineering Layers

Map 8

- |                    |                         |                         |                           |                       |
|--------------------|-------------------------|-------------------------|---------------------------|-----------------------|
| Sanitary Mains     | Pressure Release Valves | Water Meter (to verify) | Storm Mains               | Town Boundary         |
| Sani Catch Basin   | Air Release Valves      | METERVAULT              | Storm Catch Basin         | Parcels               |
| Sani Cleanout      | Water Isolation Valves  | Water meter             | Storm Cleanout            | Outside Town Boundary |
| Sani Lift Station  | Water Valve - Closed    | WTS WM                  | Storm Manhole             |                       |
| Sani Manhole       | Water Valve - Open      | FireHydrants            | Storm Outfall             |                       |
| Sani Pump Station  | Watervalue              | Water Mains             | Storm Service Cap         |                       |
| Sani Service Valve | Water Blow Offs         | WaterLeads              | Storm Private Catch Basin |                       |

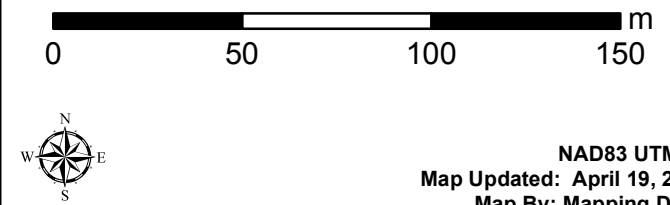

NAD83 UTM 10  
 Map Updated: April 19, 2017  
 Map By: Mapping Dept.

## Gas line location information

Please find attached the gas line location information you requested from FortisBC through BC ONE CALL.

This package includes:

1. **Instructions** - safe excavation
2. **Instructions** - if you hit a gas line
3. **Safety and permit information** from FortisBC
4. **Provincial gas safety regulations** and occupational health & safety regulations

In addition, you will also have:

- Your **gas line location map(s)** that show the location of gas lines in the area(s) where you've indicated you'll be digging
- Your **service drawing** of where the gas service line(s) can be found in the area you'll be digging
- A letter that introduces a **new icon** that appears on the location map(s) to show active gas lines

You can also visit our website for more information at [fortisbc.com/digsafe](https://fortisbc.com/digsafe).

If the information provided on your BC ONE CALL ticket does not correspond to the area in which you intend to work, as shown in the attached maps and service drawing, please call FortisBC at **1-888-822-6555**.

**To protect your safety and keep a safe worksite: please review all the items contained in this information package, including the important safety instructions on the following page, *BEFORE* you begin work.**

## 1. When excavating, you must:

- Keep gas line location information on-site at all times, and use to locate and mark lines with paint or stakes.
- Hand dig first to expose the line at several locations to determine its exact location and depth before using any mechanical equipment.
- Follow all provincial laws including WCB regulations for excavating near buried utilities.
- If you have hand exposed within 1 metre on either side of where the indicated gas line should be and you still cannot locate the gas line, OR if you have difficulties reading or understanding our location information, call FortisBC at **1-888-822-6555**.

*This illustration shows how to safely hand dig first to expose the natural gas line.*

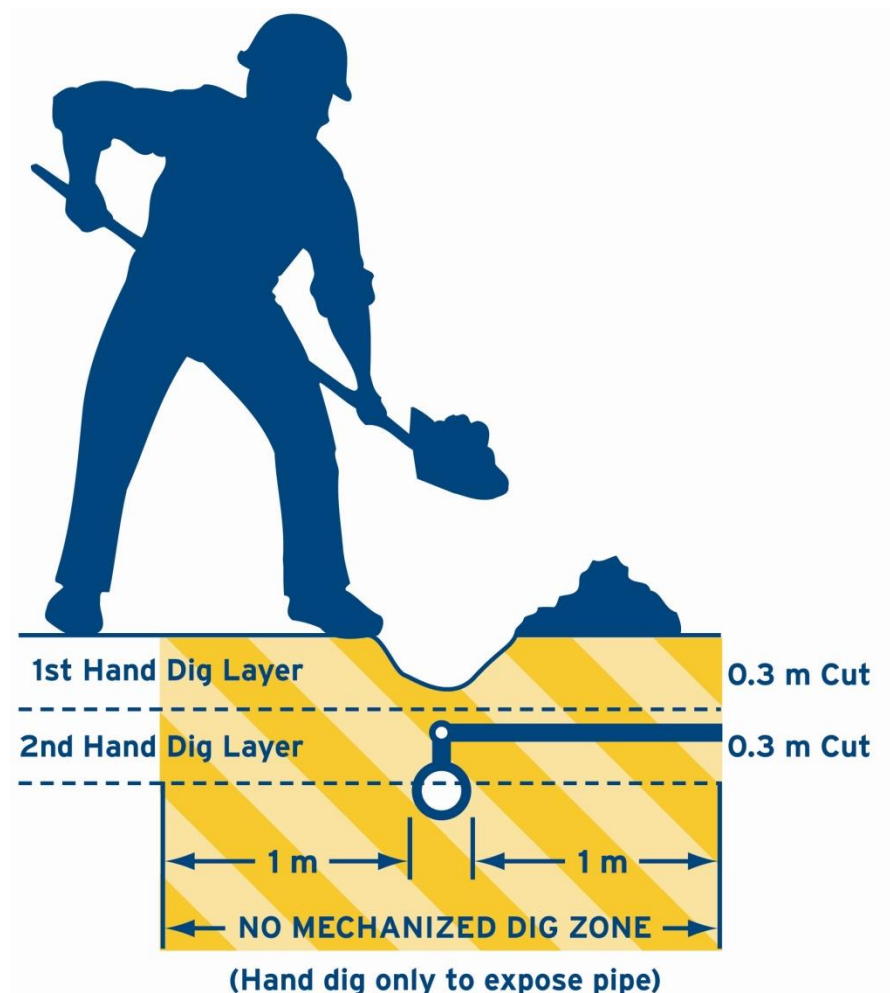



## 2. What to do if you hit a gas line

- Shut off all sources of ignition, including lit cigarettes, flares, welding torches, cell phones, power tools and equipment.
- Do not operate electrical switches — even the toggle on a light switch can generate a spark.
- Clear the area of all people.
- Stop all engines and motors.
- **Immediately call FortisBC's 24 hour emergency line at 1-800-663-9911.**

If there is danger of fire, call 911 or the fire department.

If the pipe break or the leak is underground, warn people in nearby buildings. If the possibility exists that leaking natural gas is migrating into neighbouring buildings via sewer lines and drains, evacuate all occupants immediately.

## What *not* to do if you hit a gas line

- Never attempt to make temporary repairs to a damaged gas line yourself.
- Never backfill over ruptured or damaged gas pipes.
- Do not operate any gas valves unless instructed to do so by FortisBC.

**Always call the FortisBC emergency line at 1-800-663-9911 if you damage a gas line.**

## 3. The following outlines when you need a permit or have other requirements.

### FortisBC permit

In some cases a permit is required when working around FortisBC facilities. A permit is **required** before digging when your work is:

- within **10 metres** of a **Transmission Pressure (TP)** pipeline within a public or private right of way (e.g., road allowance)
- within **2 metres** of an **Intermediate Pressure (IP)** pipeline within a public or private right of way (e.g., road allowance)
- is within a FortisBC pipeline **right of way**

### To obtain a permit:

- Call the **FortisBC Permit Desk** at **604-576-7021** or **1-877-599-0996**.
- Email your questions to **property.services@fortisbc.com**.
- Visit **fortisbc.com/rightofway**.

You may proceed with your work and a permit is **not required** when your activity takes place:

- in the area of **Distribution Pressure (DP)** gas mains
- between **30 metres and 10 metres** from an **Intermediate Pressure (IP)** pipeline

### Written permission

Within **30 metres** of a **Transmission Pressure (TP)** pipeline, you must not proceed with the activity until you have been contacted by FortisBC and obtained written permission for the activity from FortisBC.

## Onsite location

**Between 10 metres and 2 metres** from an **Intermediate Pressure (IP)** pipeline, you must call the FortisBC Public Underground Location Services Department at 1-888-822-6555 to request an on-site pipeline locate.

## Inspection

An inspection may be required if your site work or activity is within 2 metres adjacent to, over, or crossing a distribution pressure (DP) gas main with a diameter of 273mm (10 inches) or greater. Email the FortisBC Permit Desk at [property.services@fortisbc.com](mailto:property.services@fortisbc.com) or call the **Fortis BC Permit Desk** at **604-576-7021** or **1-877-599-0996**.

## Delayed work

If your activity is delayed and your excavation work has not started within 10 working days of receiving gas line location information from FortisBC, you must verify the location information through BC ONE CALL at **1-800-474-6886** before commencing the activity. The gas supply system changes constantly and line-location records can quickly become dated.

## Blasting (for contractors only)

Section 41 of the Gas Safety Regulation governs the requirements for blasting in the vicinity of gas installations. The blasting notification period does not start until after a blasting plan has been provided to FortisBC. A blasting plan must be submitted by the contractor's blasting engineer and contain the following information:

- blasting location relative to FortisBC facilities
- type and size of the charge and its delay
- declaration the blasting plan is based on the utility information provided, local ground concerns and theory
- confirmation that the blasting will not damage the utility

## Other provincial regulations to follow

The following regulations and procedures must be followed by everyone who plans to excavate around buried utilities. For complete safety regulations, visit the websites listed below.

### The Gas Safety Regulation:

[www.bclaws.ca/EPLibraries/bclaws\\_new/document/ID/freeside/15\\_103\\_2004](http://www.bclaws.ca/EPLibraries/bclaws_new/document/ID/freeside/15_103_2004) (effective April 1/04)

#### Procedures for a gas installation in vicinity of underground structures

**37 (1)** A person must not install a gas installation or allow one to be installed so that the gas installation passes through or interferes with any underground structure that is not solely for the use of a gas installation without the written permission of the owner of the underground structure.

#### Duties of persons intending to construct near gas installation

**38** A person who intends to construct an underground structure within one metre of a gas installation must notify the gas company operating in the area at least 3 business days before starting the excavation for the structure.

#### Procedures for excavations

**39 (2)** A person who intends to excavate must, at least 2 business days before the person intends to excavate, request from the gas company serving that area, or its agent, information on the location of all underground gas installations in the vicinity of the proposed excavation.

### **Hand digging to confirm location**

**39 (7)** The indicated location of gas installations must be confirmed by the excavator by means of hand digging and the excavator must expose the gas installations at a sufficient number of locations to determine their exact positions and depths before using mechanized excavation equipment for any purpose other than breaking the surface cover.

### **Gas installation not where indicated**

**39 (9)** If an excavator finds that the gas installation is not within the limits described by the gas company,  
**(a)** the excavator must so advise the gas company,  
**(b)** the gas company must immediately assist in locating and exposing the installation for the excavator,  
**(c)** mechanized excavation must not be carried on in the vicinity until the installation has been located and exposed.

### **No probing to locate gas installations**

**40** A person must not probe with pointed tools to locate gas installations.

### **Requirements for blasting in vicinity of gas installation**

**41 (1)** A person who intends to blast in the vicinity of a gas installation must

- (a)** comply with sections 37 to 39, and
- (b)** notify the relevant gas company at least 3 business days before blasting.

**(2)** If a person has already complied with sections 37 to 39 and discovers in the process of construction that blasting is required, the person must notify the relevant gas company at least 24 hours, counted only on business days, before blasting is to start.

## **Occupational Health & Safety Regulation:**

[www2.worksafebc.com/Publications/OHSRegulation/Home.asp](http://www2.worksafebc.com/Publications/OHSRegulation/Home.asp)

### **20.79 Underground utilities**

- (1)** Before excavating or drilling with powered tools and equipment, the location of all underground utility services in the area must be accurately determined, and any danger to workers from the services must be controlled.
- (2)** Excavation or drilling work in proximity to an underground service must be undertaken in conformity with the requirements of the owner of that utility service.
- (3)** Pointed tools must not be used to probe for underground petroleum and electrical utility services.
- (4)** Powered equipment used for excavating must be operated so as to avoid damage to underground utility services, or danger to workers.

*FortisBC Energy Inc. does business as FortisBC. The company is an indirect, wholly owned subsidiary of Fortis Inc. FortisBC uses the FortisBC name and logo under license from Fortis Inc.*

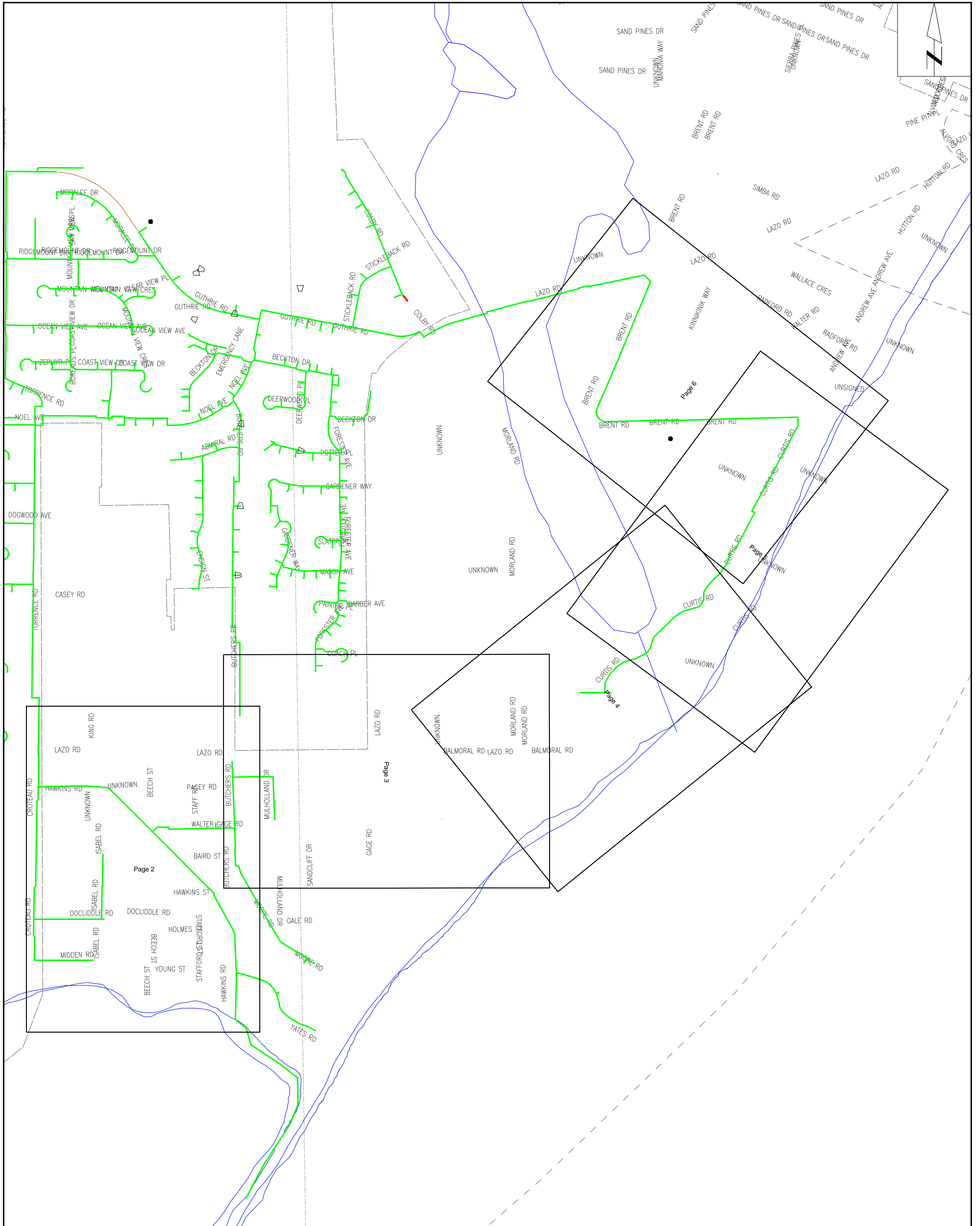

**ATTENTION:**  
 DO NOT RELY ON THIS INFORMATION ALONE!  
 You must hand dig to expose the line at several locations to determine its exact location and depth before using any mechanized equipment. All locations are approximate only. Gas lines built after the date shown, are not included in this information package. FortisBC will not accept responsibility for errors or omissions. Gas line depths are not available due to possible changes in grade. Record information provided is specific to location of original request from BC One Call. Measurements displayed in meter(s).





**ATTENTION:**  
 DO NOT RELY ON THIS INFORMATION ALONE!  
 You must hand dig to expose the line at several locations to determine its exact location and depth before using any mechanized equipment. All locations are approximate only. Gas lines built after the date shown, are not included in this information package. FortisBC will not accept responsibility for errors or omissions. Gas line depths are not available due to possible changes in grade. Record information provided is specific to location of original request from BC One Call. Measurements displayed in meters.

\*\*\* SEE AFDD'L DIG INFO \*\*\*, COMOX & AREA

TICKET # 2017123509









**ATTENTION:**  
 DO NOT RELY ON THIS INFORMATION ALONE!  
 You must hand dig to expose the line at several locations to determine its exact location and depth before using any mechanized equipment. All locations are approximate only. Gas lines built after the date shown, are not included in this information package. FortisBC will not accept responsibility for errors or omissions. Gas line depths are not available due to possible changes in grade. Record information provided is specific to location of original request from BC One Call. Measurements displayed in meters.

\*\*\* SEE AFDD'L DIG INFO \*\*\*, COMOX & AREA

TICKET # 2017123509



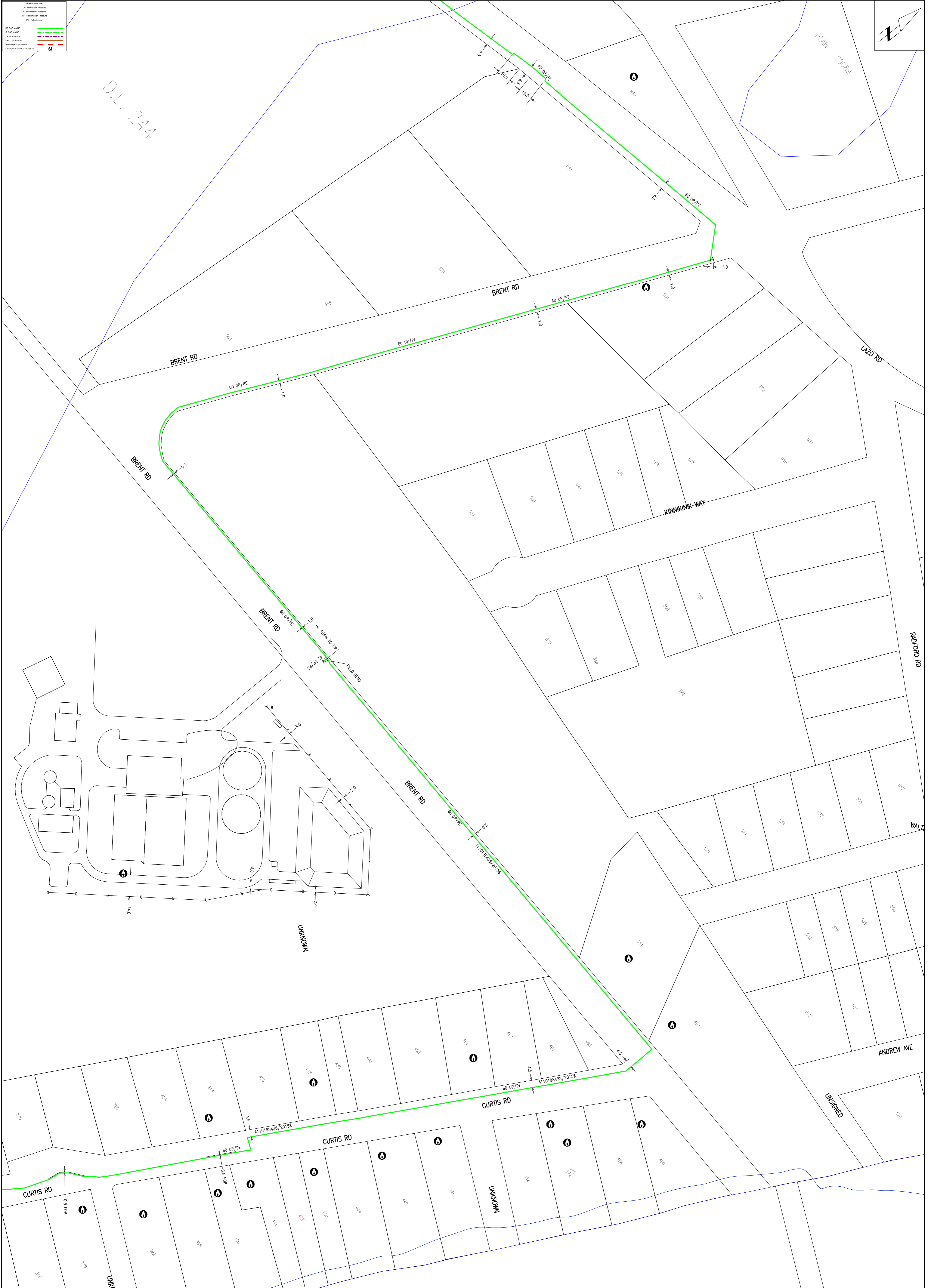

**ATTENTION:**  
 DO NOT RELY ON THIS INFORMATION ALONE!  
 You must hand dig to expose the line at several locations to determine its exact location and depth before using any mechanized equipment. All locations are approximate only. Gas lines built after the date shown, are not included in this information package. FortisBC will not accept responsibility for errors or omissions. Gas line depths are not available due to possible changes in grade. Record information provided is specific to location of original request from BC One Call. Measurements displayed in meters.

\*\*\* SEE AFDD'L DIG INFO \*\*\*, COMOX & AREA

TICKET # 2017123509

ATTENTION: DO NOT RELY ON THIS INFORMATION ALONE. You must manually dig to locate gas lines before using excavation machinery. All locations are shown approximate only & gas lines built after the date below are not in this information package. BC Gas will not accept responsibility for errors or omissions. Depth of gas line are not available due to possible change of grade.

HW45 P# 19979

# GAS SERVICE RECORD Prem. # 4088231

Address or Lot #	Street Name	Town
580	BRENT RD	COMOX-STATHCONA REG. DIST.
(Add'l Info)		(Area Code) 9136

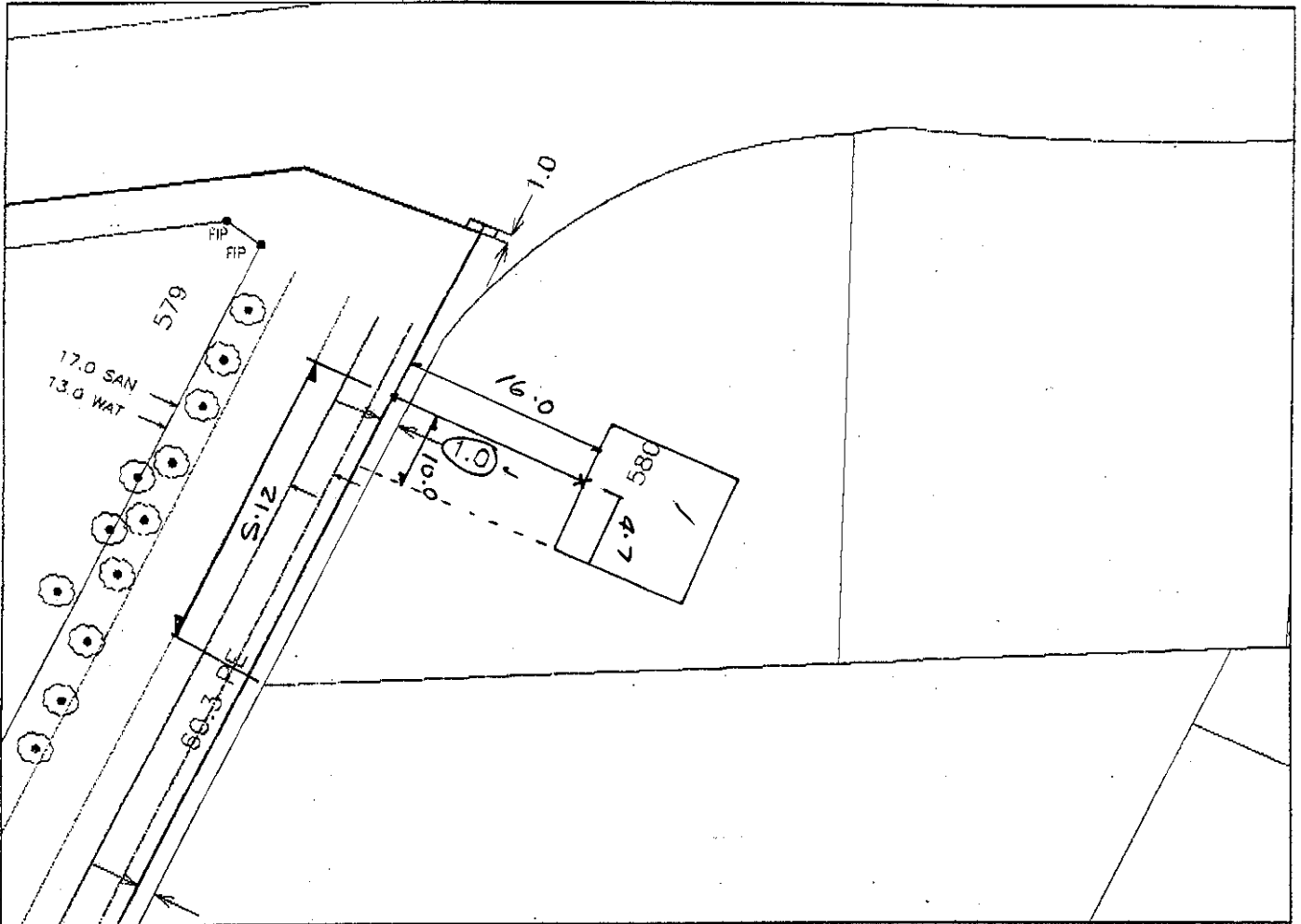

Plotted: May 10 2000 12:46:59  
User: ddbell

Scale: 1:681



MAIN DIA mm <b>60.3</b>	DEPTH AT MAIN cm <b>75</b>	C & M Report # <b>78929</b>	Milivolt Reading <b>Q</b>	PIPE MAIN SERVICE STEEL <input type="checkbox"/> PE <input checked="" type="checkbox"/>
SERVICE DIA mm <b>15.9</b>	DEPTH AT PL cm <b>60</b>	AIR TEST <b>800</b> kPa for <b>15</b> Minutes	SIGNATURE: _____	CONTRACTOR / COMPANY CREW <b>CUC 131-24</b>
PE COIL # <b>172</b>	PIPE MANUFACTURER <b>W810</b>	PIPE INSPECT. DATE <b>99 06 29</b>	SERVICE PIPE INSTALLED: Main To Property Line (metres) <b>1.0</b> Property Line To Riser (metres) <b>15.0</b> TOTAL SERVICE LENGTH (metres) <b>16.0</b>	FUSERS NAME (Print) <b>S.M.P.Y</b> DATE INSTALLED <b>16 05 00</b> D M Y

Distribution: ORIGINAL - DISTRICT OFFICE, COPY - HEAD OFFICE, COPY - MUNICIPALITY OFFICE

ATTENTION: DO NOT RELY ON THIS INFORMATION ALONE. You must manually dig to locate gas lines before using excavation machinery. All locations are shown approximate only & gas lines built after the date below are not in this information package. BC Gas will not accept responsibility for errors or omissions. Depth of gas line are not available due to possible change of grade.



**T-DOC**

946100-STB1

Job Number **30395035** Job address **580 Brent rd Comox**

Location/description of work/additional comments  
 Installed 15.4 m of 15.9 mm pe service pipe / riser to address meter installed  
 came off a 1.0 on 15.9 mm pe stub

<b>Service Pipe</b>	<b>Length (m)</b>	<b>Size (mm)</b>	<b>Material</b>	<b>Service cut off at:</b> <input type="checkbox"/> Main <input type="checkbox"/> Inside PL <input type="checkbox"/> Outside PL <input type="checkbox"/> At PL <input type="checkbox"/> At HDR <input type="checkbox"/> Other	<b>Abandoned pipe</b> _____ (m) _____ (mm) Length Size	<b>Material</b> <input type="checkbox"/> PE <input type="checkbox"/> ST <input type="checkbox"/> Stub marker ball
Stub Main to PL	5 16.4	15.9	<input checked="" type="checkbox"/> PE <input type="checkbox"/> ST			
PL to safe meter location (per code)	10.0	15.9	<input checked="" type="checkbox"/> PE <input type="checkbox"/> ST			
Extended past safe meter location (per customer)			<input type="checkbox"/> PE <input type="checkbox"/> ST			
<b>Total Service Length</b>	5 16.4	Main to meter location				
Riser (vertical)	1.8	15.9	<input checked="" type="checkbox"/> PE <input type="checkbox"/> ST			

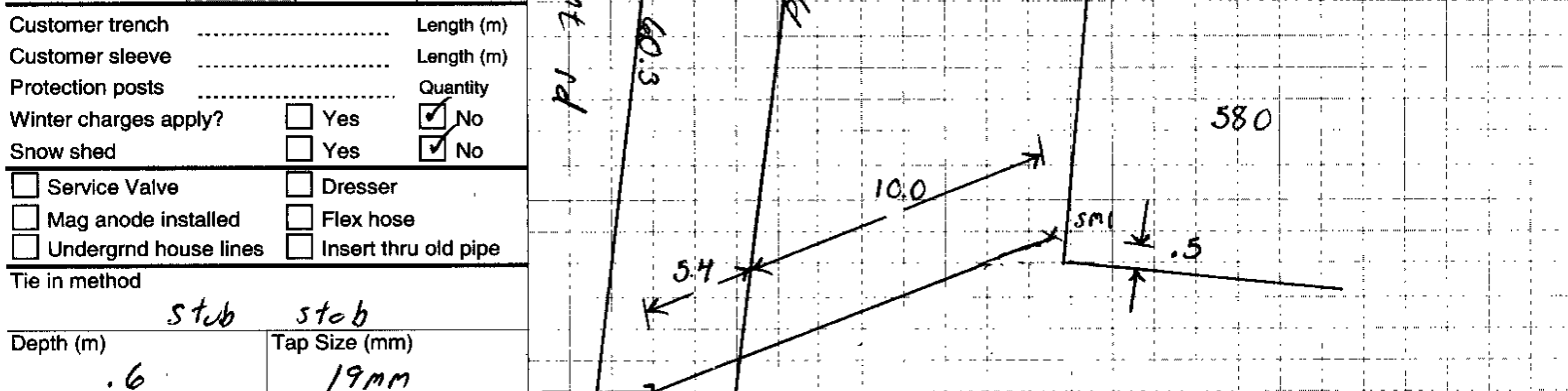

Customer trench _____ Length (m)	Customer sleeve _____ Length (m)	Protection posts _____ Quantity	Winter charges apply? <input type="checkbox"/> Yes <input checked="" type="checkbox"/> No	Snow shed <input type="checkbox"/> Yes <input checked="" type="checkbox"/> No
<input type="checkbox"/> Service Valve	<input type="checkbox"/> Dresser	<input type="checkbox"/> Mag anode installed	<input type="checkbox"/> Flex hose	<input type="checkbox"/> Undergrnd house lines
<input type="checkbox"/> Insert thru old pipe	<b>Tie in method</b> Stub Stub			
Depth (m) .6	Tap Size (mm) 19mm	<b>Test Method</b>		
<input checked="" type="checkbox"/> Air	Pressure (kPa) 800	Duration 15 min		
<input type="checkbox"/> Nitrogen				
<input type="checkbox"/> Soap test	<input type="checkbox"/> Radiography (X-ray)			
<input checked="" type="checkbox"/> Tracer-wire continuity				
<input type="checkbox"/> Other				
<b>Service location is</b> 12.3105 meters 932 (direction) N from S PI				

<b>Meter location</b>	<input type="checkbox"/> Left-hand side	<input checked="" type="checkbox"/> Right-hand side	<b>Leak category</b>	<input type="checkbox"/> 1	<input type="checkbox"/> 2	<input type="checkbox"/> 3	<b>Leak repair</b>	<input type="checkbox"/> Permanent	<input type="checkbox"/> Temporary	<b>Leak check</b>	<input type="checkbox"/> Odor recheck	<input type="checkbox"/> Bottle/bag sample taken
<input type="checkbox"/> Remote	<input type="checkbox"/> Front left	<input type="checkbox"/> Front right										
	<input type="checkbox"/> Back left	<input type="checkbox"/> Back right										

<input checked="" type="checkbox"/> Install	<input type="checkbox"/> Remove	<input type="checkbox"/> Reset	Unit No. or Address 580 Brent rd	Terasen Gas Meter No. Rct 692530	Manufacturer's No. 14048530	Dials 4	Reading 1387	Del. Press 14	PFM Number FE 8703
<input type="checkbox"/> Install	<input type="checkbox"/> Remove	<input type="checkbox"/> Reset							

<b>Scheduling</b>	<input checked="" type="checkbox"/> Customer contacted	<input type="checkbox"/> Left message	<b>Estimated additional charges</b>	<input checked="" type="checkbox"/> No add. charges	<input type="checkbox"/> Unable to contact cust	<b>Crew sign off</b>	<input type="checkbox"/> Terasen Gas	<input checked="" type="checkbox"/> Contractor
Date contacted (Yr/Mth/Day) 11 01 04	Rescheduled date (Yr/Mth/Day)		<input type="checkbox"/> Customer notified of additional charges	<input type="checkbox"/> Customer approved additional charges		I hereby certify that the work was completed in accordance with the company standard practices.		
Notes	Customer name		Total estimated additional charges	\$		Crew leader (PRINT) TK1999	Crew leader signature TK1999	Date (Yr/Mth/Day) 11 01 04





ATTENTION: DO NOT RELY ON THIS INFORMATION ALONE. You must manually dig to locate gas lines before using excavation machinery. All locations are shown approximate only & gas lines built after the date below are not in this information package. BC Gas will not accept responsibility for errors or omissions. Depth of gas line are not available due to possible change of grade.

T-DOC



Job number: 30821057 For office use only: Premise number: 10045920001 - New

Job address: 260 CURTIS RD. COMOX

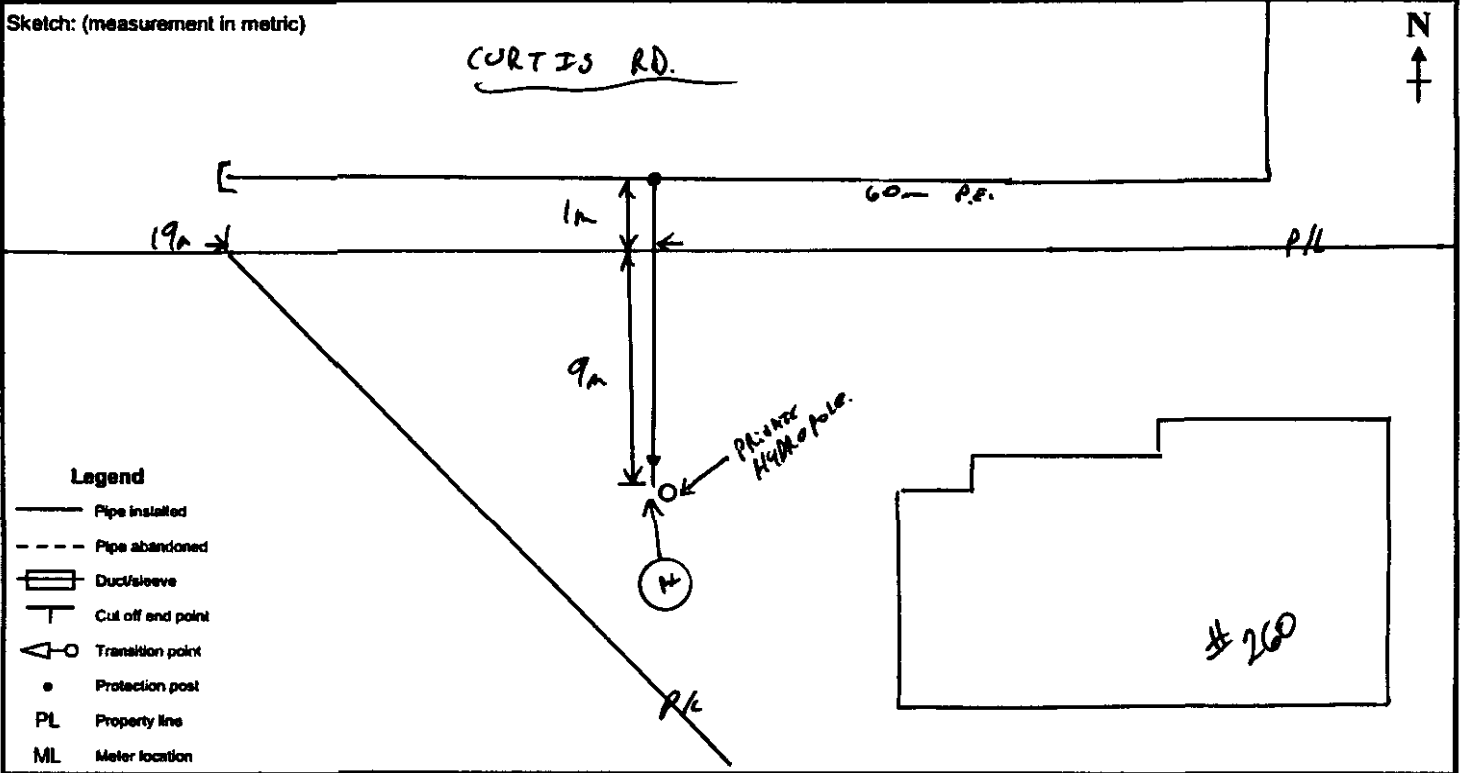

Description of work/additional comments: 10m of 26mm PE SERVICE INSTALLED.

JCR # 64750

Customer trench length (m) <input checked="" type="checkbox"/>	Customer sleeve length (m) <input checked="" type="checkbox"/>	Protection posts quantity <input checked="" type="checkbox"/>	Winter charges apply? <input type="checkbox"/> Yes <input checked="" type="checkbox"/> No	Snow shed <input type="checkbox"/> Yes <input checked="" type="checkbox"/> No	Tie in method: 60x26mm E.F.T.	Depth of main (m): 0.8	Tap size (mm): 19	Valve details: New Installs (mandatory) or Existing (if known)
<input type="checkbox"/> Dresser	<input type="checkbox"/> Mag anode installed	<input type="checkbox"/> Insert thru old pipe	<input type="checkbox"/> Boring tool used	<input type="checkbox"/> Stub marker ball	Pressure test: <input checked="" type="checkbox"/> Air 800 kPa, 10 min	<input type="checkbox"/> Nitrogen	<input type="checkbox"/> Hydrostatic	Manufacturer: _____
Inspections: <input type="checkbox"/> Radiography (X-ray) <input checked="" type="checkbox"/> Tracer wire continuity <input type="checkbox"/> NDI of welds <input type="checkbox"/> Other					Model: _____	Serial: _____	Valve ID: _____	Leak category: <input type="checkbox"/> 1 <input type="checkbox"/> 2
					Leak repair: <input type="checkbox"/> Permanent <input type="checkbox"/> Temporary			

NON-MOBILE COMPLETION USERS ONLY

Extended past safe meter location	Length (m)	Size (mm)	Material
Abandoned pipe	(m)	(mm)	<input type="checkbox"/> PE <input type="checkbox"/> ST
Unit No. or address	FortisBC Meter No.	Manufacturer's No.	Dials Reading Del. Press Reg tag
<input checked="" type="checkbox"/> Install	260	RCT1363978	19625978 4 0 14 CP 5817
<input type="checkbox"/> Remove			
<input type="checkbox"/> Reset			
<input type="checkbox"/> Install			
<input type="checkbox"/> Remove			
<input type="checkbox"/> Reset			

ID number: 4060 Completion date (Yr/Mth/Day): 15/12/15

ATTENTION: DO NOT RELY ON THIS INFORMATION ALONE. You must manually dig to locate gas lines before using excavation machinery. All locations are shown approximate only & gas lines built after the date below are not in this information package. BC Gas will not accept responsibility for errors or omissions. Depth of gas line are not available due to possible change of grade.

T-DOC



10048349001- New

Job number 30834254 Premises number

Job address 281 CURTIS RD.

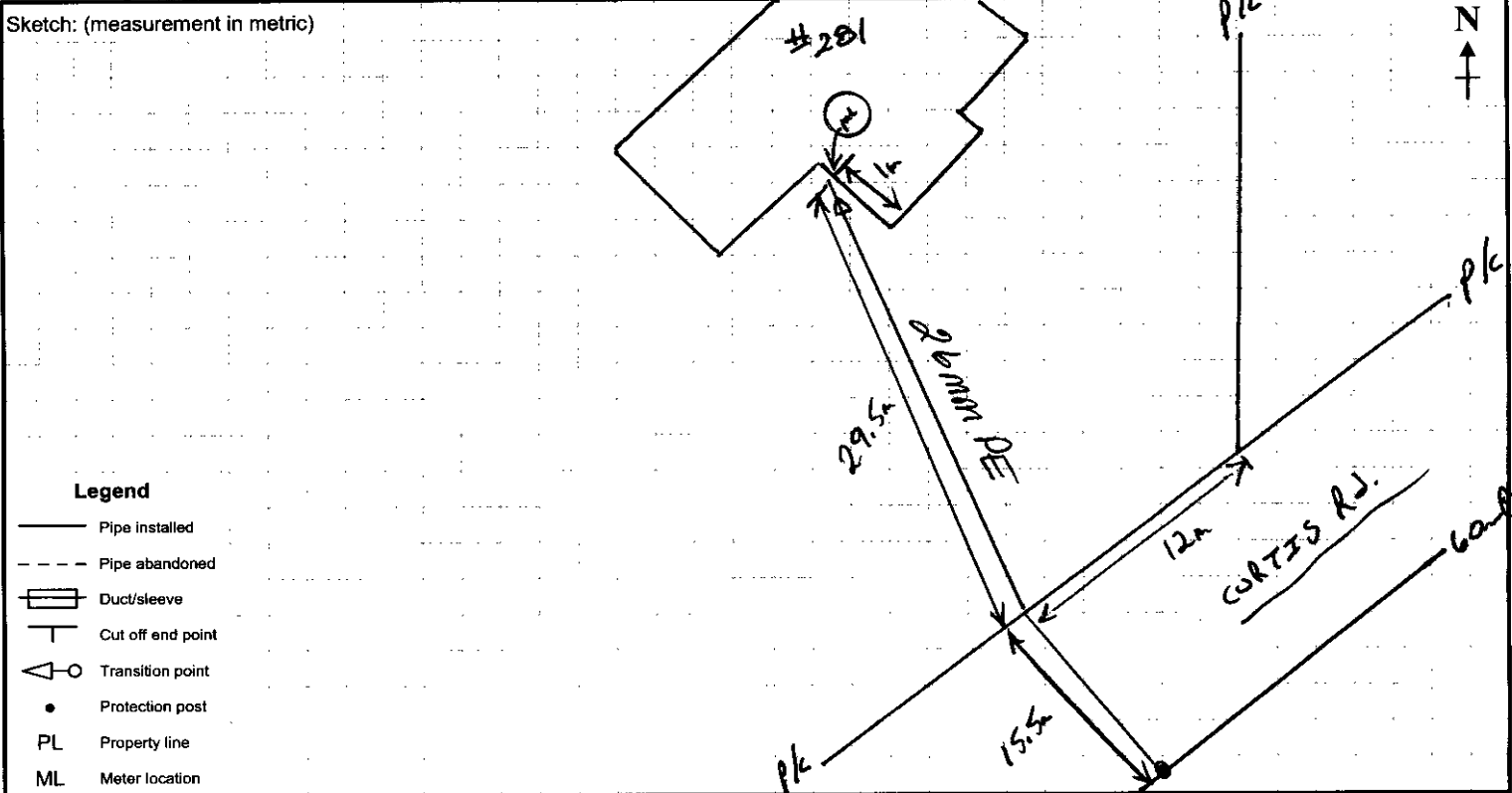

Description of work/additional comments:  
45m OF 26mm P.E. SERVICE INSTALLED.

Customer trench <u>        </u> length (m) Customer sleeve <u>        </u> length (m) Protection posts <u>        </u> quantity Winter charges apply? <input type="checkbox"/> Yes <input checked="" type="checkbox"/> No Snow shed <input type="checkbox"/> Yes <input checked="" type="checkbox"/> No <input type="checkbox"/> Dresser <input type="checkbox"/> Mag anode installed <input type="checkbox"/> Insert thru old pipe <input checked="" type="checkbox"/> Boring tool used <input type="checkbox"/> Stub marker ball	Tie in method <u>60x26mm E.F.T.</u> Depth of main (m) <u>1.3</u> Tap size (mm) <u>19</u> Pressure test <input checked="" type="checkbox"/> Air <u>800</u> <u>10min</u> <input type="checkbox"/> Nitrogen <input type="checkbox"/> Hydrostatic <input checked="" type="checkbox"/> Soap test Inspections: <input type="checkbox"/> Radiography (X-ray) <input checked="" type="checkbox"/> Tracer wire continuity <input type="checkbox"/> NDI of welds <input type="checkbox"/> Other	Valve details: New Installs (mandatory) or Existing (if known) <input type="checkbox"/> Service valve <input type="checkbox"/> Main valve Manufacturer _____ Model _____ Serial _____ Valve ID _____ Leak category <input type="checkbox"/> 1 <input type="checkbox"/> 2 <input type="checkbox"/> Bottle/bag sample taken Leak repair <input type="checkbox"/> Permanent <input type="checkbox"/> Temporary
---	---	--

**NON-MOBILE COMPLETION USERS ONLY**

	Length (m)	Size (mm)	Material				
Extended past safe meter location	(m)	(mm)	<input type="checkbox"/> PE <input type="checkbox"/> ST				
Abandoned pipe	(m)	(mm)	<input type="checkbox"/> PE <input type="checkbox"/> ST				
Unit No. or address	FortisBC Meter No.	Manufacturer's No.	Dials	Reading	Del. Press	Reg tag	
<input checked="" type="checkbox"/> Install <input type="checkbox"/> Remove <input type="checkbox"/> Reset	<u>281</u>	<u>RCT1362767</u>	<u>19624767</u>	<u>4</u>	<u>Ø</u>	<u>14</u>	<u>EF 4085</u>
<input type="checkbox"/> Install <input type="checkbox"/> Remove <input type="checkbox"/> Reset							

ID number 4060 b. Miller. Completion date (Yr/Mth/Day) 16/02/24

ATTENTION: DO NOT RELY ON THIS INFORMATION ALONE. You must manually dig to locate gas lines before using excavation machinery. All locations are shown approximate only & gas lines built after the date below are not in this information package. BC Gas will not accept responsibility for errors or omissions. Depth of gas line are not available due to possible change of grade.

T-DOC



Job number **30855885** For office use only: Premise number: **10052707001 - New**

Job address **301 CURTIS RD.**

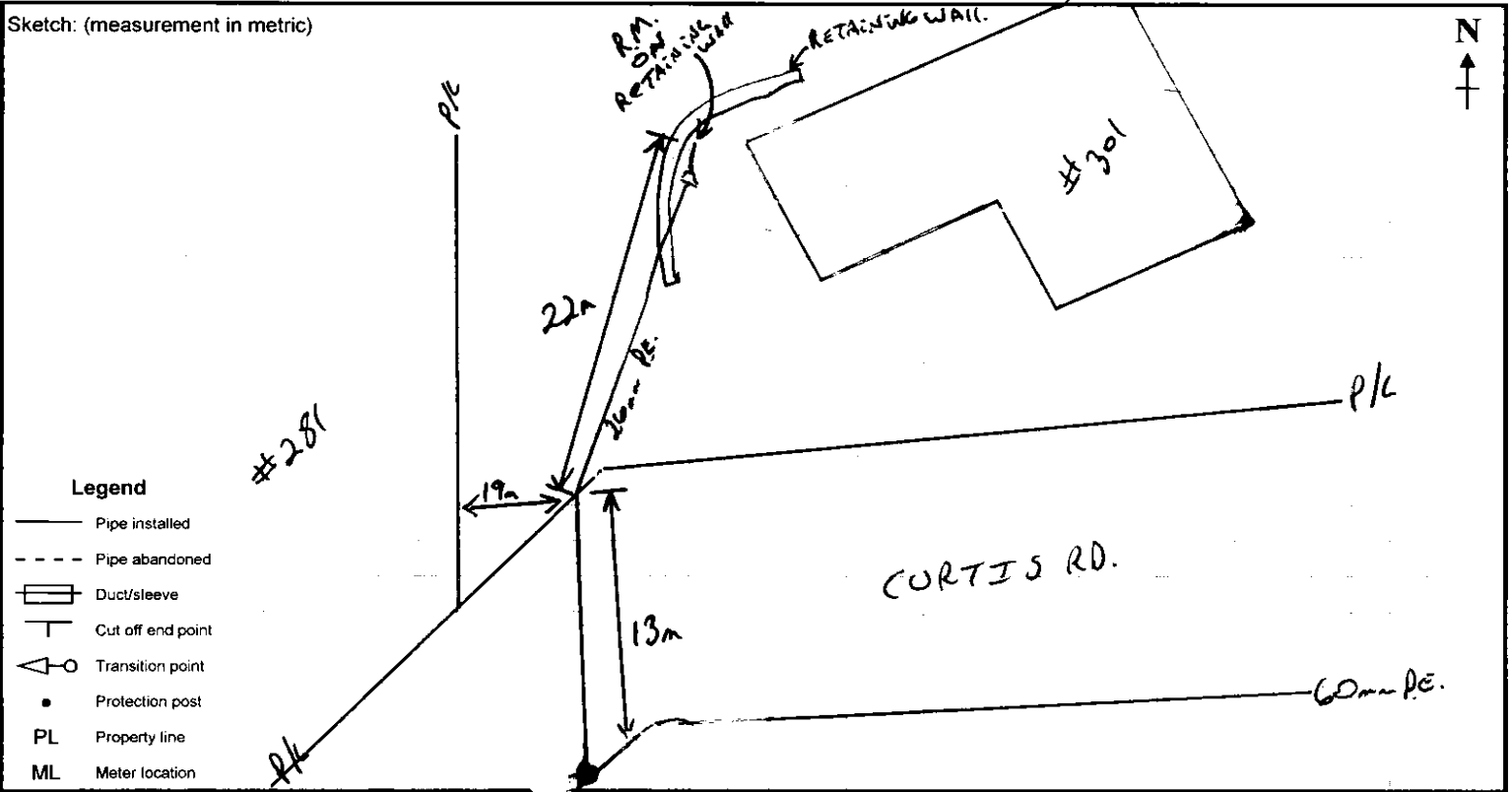

Description of work/additional comments:  
**35m OF 26mm PE. SERVICE INSTALLED.**

Customer trench	length (m)	Tie in method	<b>60x26mm E.F.T.</b>	Valve details:
Customer sleeve	length (m)	Depth of main (m)	<b>1.3</b>	New Installs (mandatory) or Existing (if known)
Protection posts	quantity	Tap size (mm)	<b>19</b>	<input type="checkbox"/> Service valve <input type="checkbox"/> Main valve
Winter charges apply?	<input type="checkbox"/> Yes <input checked="" type="checkbox"/> No	Pressure test	Pressure (kPa) <b>800</b> Duration <b>10 min</b>	Manufacturer
Snow shed	<input type="checkbox"/> Yes <input checked="" type="checkbox"/> No	<input checked="" type="checkbox"/> Air <input type="checkbox"/> Nitrogen <input type="checkbox"/> Hydrostatic <input checked="" type="checkbox"/> Soap test		Model
<input type="checkbox"/> Dresser		Inspections:		Serial
<input type="checkbox"/> Mag anode installed		<input type="checkbox"/> Radiography (X-ray) <input checked="" type="checkbox"/> Tracer wire continuity		Valve ID
<input type="checkbox"/> Insert thru old pipe		<input type="checkbox"/> NDI of welds <input type="checkbox"/> Other		Leak category <input type="checkbox"/> 1 <input type="checkbox"/> 2
<input type="checkbox"/> Boring tool used				<input type="checkbox"/> Bottle/bag sample taken
<input type="checkbox"/> Stub marker ball				Leak repair <input type="checkbox"/> Permanent <input type="checkbox"/> Temporary

NON-MOBILE COMPLETION USERS ONLY

Extended past safe meter location	Length (m)	Size (mm)	Material
Abandoned pipe	(m)	(mm)	<input type="checkbox"/> PE <input type="checkbox"/> ST
	(m)	(mm)	<input type="checkbox"/> PE <input type="checkbox"/> ST

Unit No. or address	FortisBC Meter No.	Manufacturer's No.	Dials	Reading	Del. Press	Reg tag
<b>301</b>	<b>RCT1387373</b>	<b>20052372</b>	<b>4</b>	<b>Φ</b>	<b>14</b>	<b>EF11090</b>

ID number **4060** **B. Miller** Completion date (Yr/Mth/Day) **16/07/07**

ATTENTION: DO NOT RELY ON THIS INFORMATION ALONE. You must manually dig to locate gas lines before using excavation machinery. All locations are shown approximate only & gas lines built after the date below are not in this information package. BC Gas will not accept responsibility for errors or omissions. Depth of gas line are not available due to possible change of grade.

T-DOC



Job number  
30825206

For office use only:  
Premise number: 10046891001- New

Job address  
324 CURTIS RD.

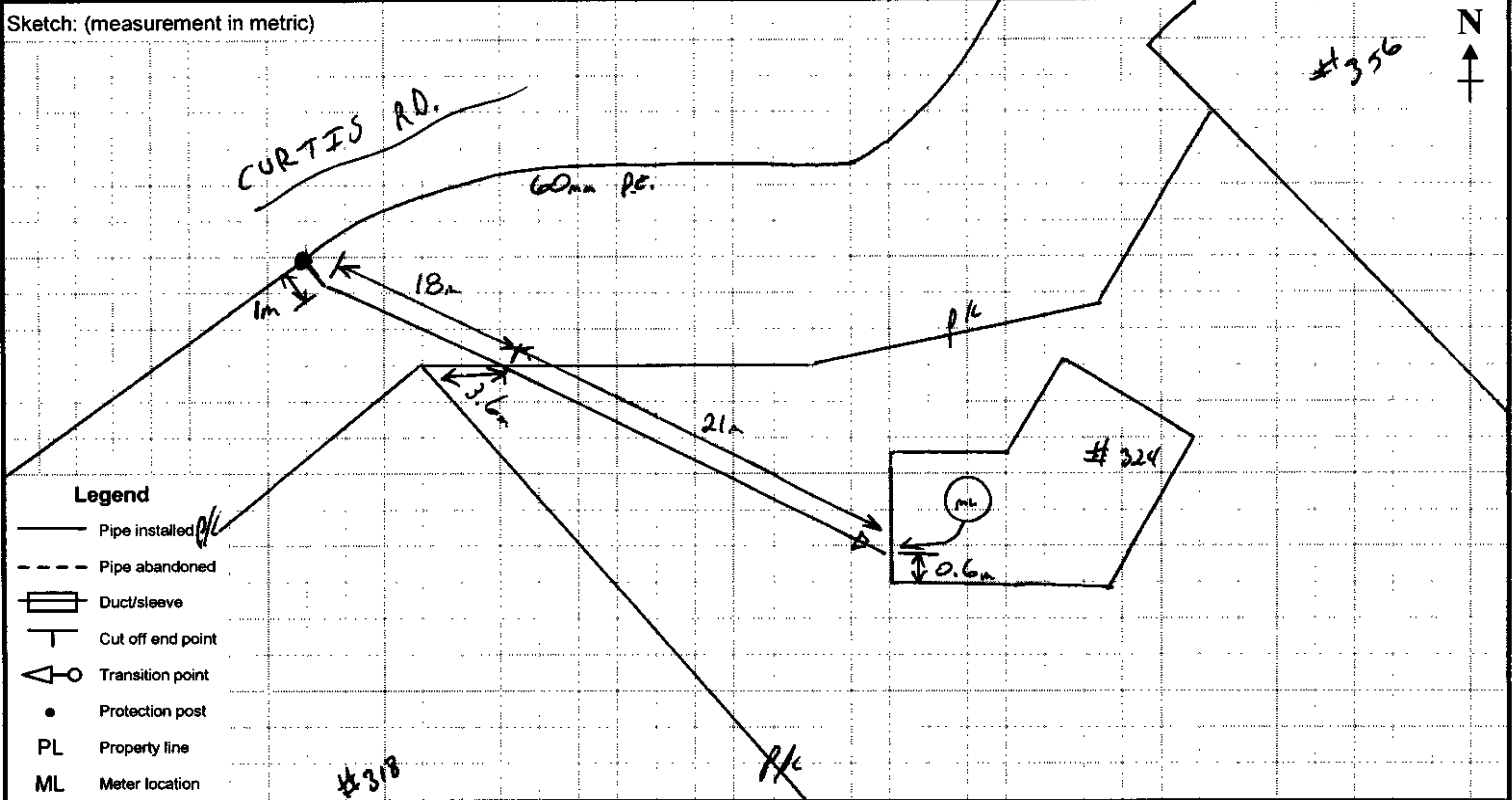

Description of work/additional comments:  
40m of 26mm P.E. SERVICE INSTALLED.

JCR # 65397

Customer trench _____ length (m)	Tie in method <u>60x26mm E.F.T.</u>	Valve details:
Customer sleeve _____ length (m)	Depth of main (m) <u>1.2</u>	New Installs (mandatory) or Existing (if known)
Protection posts _____ quantity	Tap size (mm) <u>19</u>	<input type="checkbox"/> Service valve <input type="checkbox"/> Main valve
Winter charges apply? <input type="checkbox"/> Yes <input checked="" type="checkbox"/> No	Pressure test	Manufacturer _____
Snow shed <input type="checkbox"/> Yes <input checked="" type="checkbox"/> No	<input checked="" type="checkbox"/> Air      Pressure (kPa) <u>800</u> Duration <u>10min</u>	Model _____
<input type="checkbox"/> Dresser	<input type="checkbox"/> Nitrogen	Serial _____
<input type="checkbox"/> Mag anode installed	<input type="checkbox"/> Hydrostatic	Valve ID _____
<input type="checkbox"/> Insert thru old pipe	<input checked="" type="checkbox"/> Soap test	Leak category <input type="checkbox"/> 1 <input type="checkbox"/> 2
<input checked="" type="checkbox"/> Boring tool used	Inspections:	<input type="checkbox"/> Bottle/bag sample taken
<input type="checkbox"/> Stub marker ball	<input type="checkbox"/> Radiography (X-ray) <input checked="" type="checkbox"/> Tracer wire continuity	Leak repair <input type="checkbox"/> Permanent <input type="checkbox"/> Temporary
	<input type="checkbox"/> NDI of welds <input type="checkbox"/> Other	

NON-MOBILE COMPLETION USERS ONLY

	Length (m)	Size (mm)	Material			
Extended past safe meter location			<input type="checkbox"/> PE <input type="checkbox"/> ST			
Abandoned pipe			<input type="checkbox"/> PE <input type="checkbox"/> ST			
Unit No. or address	FortisBC Meter No.	Manufacturer's No.	Dials	Reading	Del. Press	Reg tag
<input checked="" type="checkbox"/> Install	324	RCT1363967	19625967	4	φ	14
<input type="checkbox"/> Remove						
<input type="checkbox"/> Reset						
<input type="checkbox"/> Install						
<input type="checkbox"/> Remove						
<input type="checkbox"/> Reset						

ID number  
4060

Completion date (yr/Mth/Day)  
15/02/14

ATTENTION: DO NOT RELY ON THIS INFORMATION ALONE. You must manually dig to locate gas lines before using excavation machinery. All locations are shown approximate only & gas lines built after the date below are not in this information package. BC Gas will not accept responsibility for errors or omissions. Depth of gas line are not available due to possible change of grade.

T-DOC

"Service install"



Job number: 30825208 For office use only: Premise number: 10046893001

Job address: 362 Curtis Rd, Comox

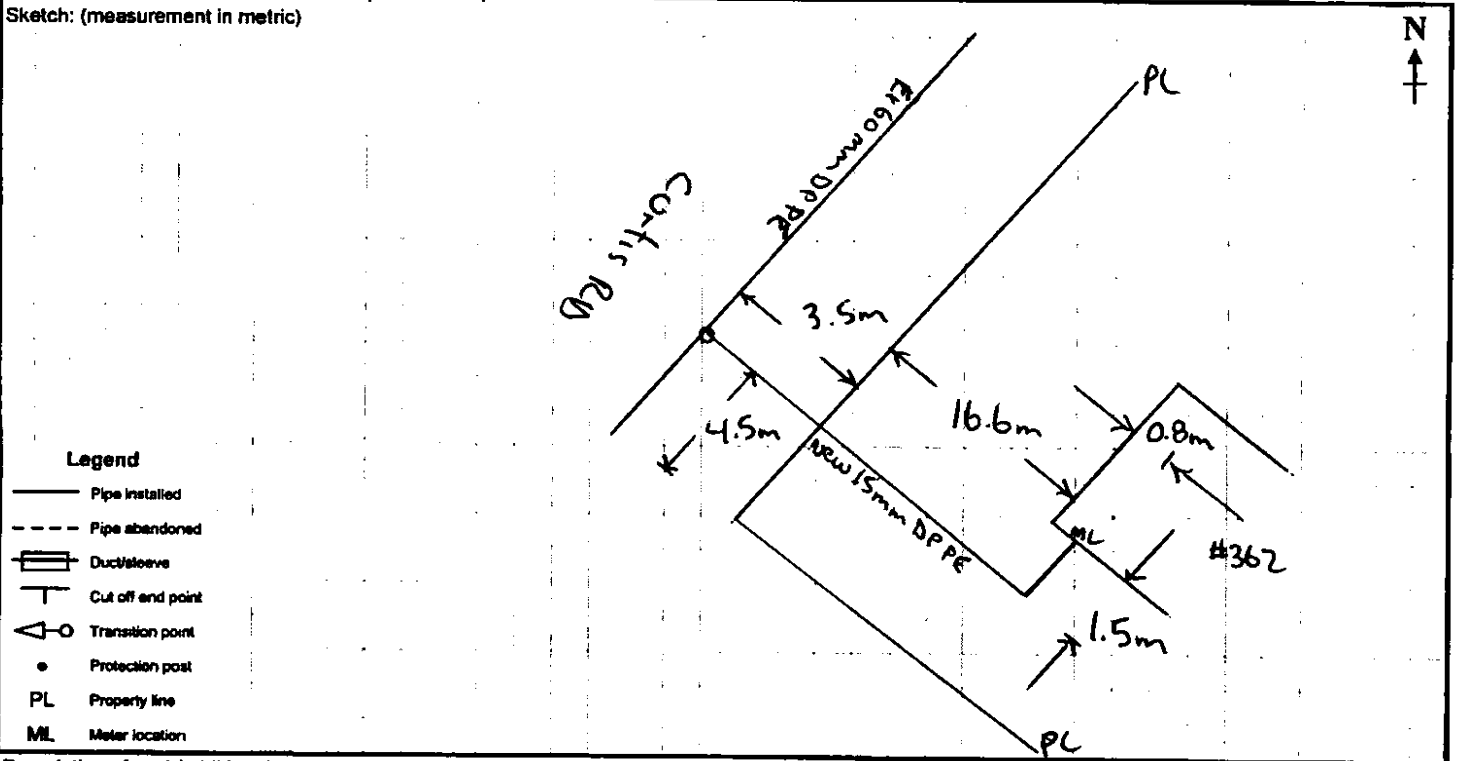

Description of work/additional comments: Installed 22.4 meters of 15mm DP PE Service

Customer trench _____ length (m)	Tie in method <u>EFT</u>	Valve details:
Customer sleeve _____ length (m)	Depth of main (m) <u>0.9</u>	<i>New Installs (mandatory) or Existing (if known)</i>
Protection posts _____ quantity	Tap size (mm) <u>19</u>	<input type="checkbox"/> Service valve <input type="checkbox"/> Main valve
Winter charges apply? <input type="checkbox"/> Yes <input checked="" type="checkbox"/> No	Pressure test	Manufacturer _____
Snow shed <input type="checkbox"/> Yes <input checked="" type="checkbox"/> No	<input checked="" type="checkbox"/> Air    Pressure (kPa) <u>800</u> Duration <u>10min</u>	Model _____
<input type="checkbox"/> Dresser	<input type="checkbox"/> Nitrogen	Serial _____
<input type="checkbox"/> Mag anode installed	<input type="checkbox"/> Hydrostatic	Valve ID _____
<input type="checkbox"/> Insert thru old pipe	<input checked="" type="checkbox"/> Soap test	Leak category <input type="checkbox"/> 1 <input type="checkbox"/> 2
<input type="checkbox"/> Boring tool used	Inspections:	<input type="checkbox"/> Bottle/bag sample taken
<input type="checkbox"/> Stub marker ball	<input type="checkbox"/> Radiography (X-ray) <input checked="" type="checkbox"/> Tracer wire continuity	Leak repair <input type="checkbox"/> Permanent <input type="checkbox"/> Temporary
	<input type="checkbox"/> NDI of welds <input type="checkbox"/> Other	

NON-MOBILE COMPLETION USERS ONLY

	Length (m)	Size (mm)	Material				
Extended past safe meter location			<input type="checkbox"/> PE <input type="checkbox"/> ST				
Abandoned pipe			<input type="checkbox"/> PE <input type="checkbox"/> ST				
Unit No. or address	FortisBC Meter No.	Manufacturer's No.	Dials	Reading	Del. Press	Reg tag	
<input checked="" type="checkbox"/> Install	<u>362</u>	<u>Rct1362411</u>	<u>1362411</u>	<u>4</u>	<u>∅</u>	<u>14kps</u>	<u>EFS327</u>
<input type="checkbox"/> Remove							
<input type="checkbox"/> Reset							
<input type="checkbox"/> Install							
<input type="checkbox"/> Remove							
<input type="checkbox"/> Reset							

ID number: 4060 C. Hemstall Completion date (Yr/Mon/Day): 16/03/29

ATTENTION: DO NOT RELY ON THIS INFORMATION ALONE. You must manually dig to locate gas lines before using excavation machinery. All locations are shown approximate only & gas lines built after the date below are not in this information package. BC Gas will not accept responsibility for errors or omissions. Depth of gas line are not available due to possible change of grade.

T-DOC



Job number 3082 5211

For office use only  
Premise number: 10046894001 - New

Job address 378 CURTIS RD.

COMOX.

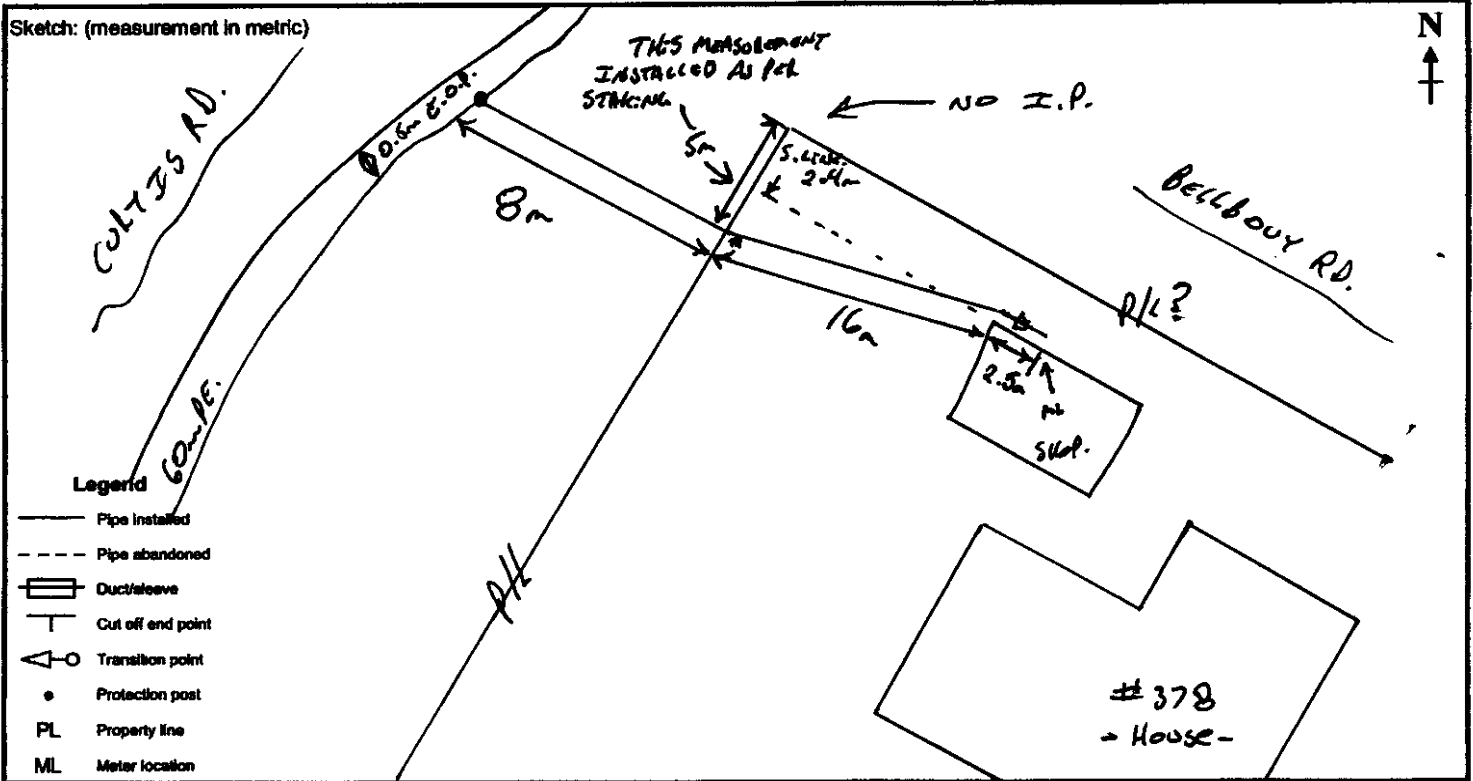

Description of work/additional comments:

26.5m of 26mm PE SERVICE INSTALLED AS PER STAKING-

Customer trench length (m) <u>        </u>	Tie in method <u>60x26mm E.F.T.</u>	Valve details:
Customer sleeve length (m) <u>        </u>	Depth of main (m) <u>1.2</u>	New Installs (mandatory) or Existing (if known)
Protection posts quantity <u>        </u>	Tap size (mm) <u>19</u>	<input type="checkbox"/> Service valve <input type="checkbox"/> Main valve
Winter charges apply? <input type="checkbox"/> Yes <input checked="" type="checkbox"/> No	Pressure test	Manufacturer <u>        </u>
Snow shed <input type="checkbox"/> Yes <input checked="" type="checkbox"/> No	<input checked="" type="checkbox"/> Air    Pressure (kPa) <u>800</u> Duration <u>10min</u>	Model <u>        </u>
<input type="checkbox"/> Dresser	<input type="checkbox"/> Nitrogen	Serial <u>        </u>
<input type="checkbox"/> Mag anode installed	<input type="checkbox"/> Hydrostatic	Valve ID <u>        </u>
<input type="checkbox"/> Insert thru old pipe	<input checked="" type="checkbox"/> Soap test	Leak category <input type="checkbox"/> 1 <input type="checkbox"/> 2
<input checked="" type="checkbox"/> Boring tool used	Inspections:	<input type="checkbox"/> Bottle/bag sample taken
<input type="checkbox"/> Stub marker ball	<input type="checkbox"/> Radiography (X-ray) <input checked="" type="checkbox"/> Tracer wire continuity	Leak repair <input type="checkbox"/> Permanent <input type="checkbox"/> Temporary
	<input type="checkbox"/> NDI of welds <input type="checkbox"/> Other	

NON-MOBILE COMPLETION USERS ONLY

	Length (m)	Size (mm)	Material			
Extended past safe meter location			<input type="checkbox"/> PE	<input type="checkbox"/> ST		
Abandoned pipe			<input type="checkbox"/> PE	<input type="checkbox"/> ST		
Unit No. or address	FortisBC Meter No.	Manufacturer's No.	Dials	Reading	Del. Press	Reg tag
<input checked="" type="checkbox"/> Install	378	RCT1362765	4	∅	14	EF 2132
<input type="checkbox"/> Remove						
<input type="checkbox"/> Reset						
<input type="checkbox"/> Install						
<input type="checkbox"/> Remove						
<input type="checkbox"/> Reset						

ID number 4060

B. Miller

Completion date (Yr/Mth/Day) 16/02/12



ATTENTION: DO NOT RELY ON THIS INFORMATION ALONE. You must manually dig to locate gas lines before using excavation machinery. All locations are shown approximate only & gas lines built after the date below are not in this information package. BC Gas will not accept responsibility for errors or omissions. Depth of gas line are not available due to possible change of grade.

T-DOC



Job number  
30827278

For office use only:  
Premise number: 10047260001 NEW

Job address  
392 CURTIS RD.

COMOX.

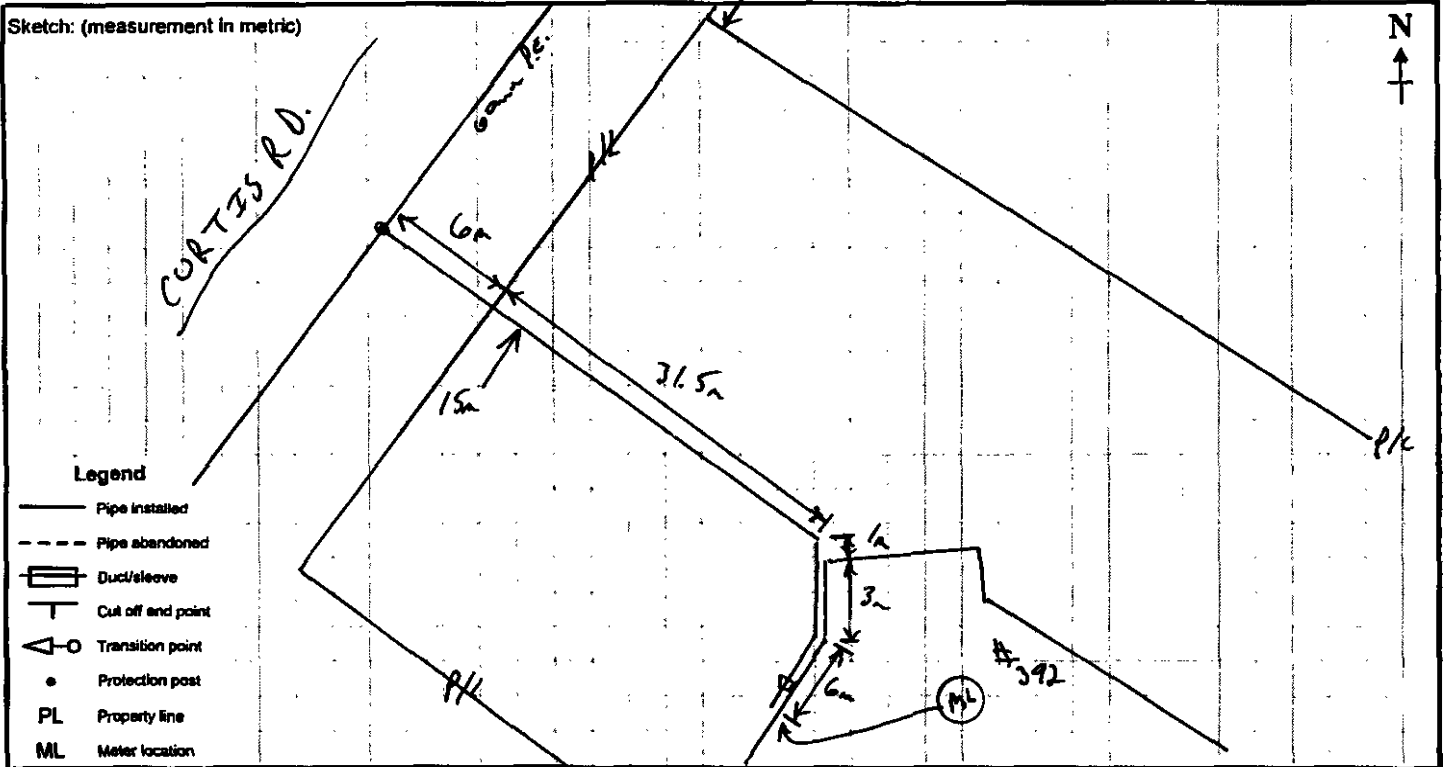

Description of work/additional comments:  
47.5m. OF 26mm P.E. SERVICE INSTALLED.

JCR# 65398

Customer trench _____ length (m)	Tie in method <u>60 x 26mm P.T.T.</u>	Valve details:
Customer sleeve _____ length (m)	Depth of main (m) <u>1.2</u>	New Installs (mandatory) or Existing (if known)
Protection posts _____ quantity	Tap size (mm) <u>19</u>	<input type="checkbox"/> Service valve <input type="checkbox"/> Main valve
Winter charges apply? <input type="checkbox"/> Yes <input checked="" type="checkbox"/> No	Pressure test	Manufacturer _____
Snow shed <input type="checkbox"/> Yes <input checked="" type="checkbox"/> No	<input checked="" type="checkbox"/> Air      Pressure (kPa) <u>800</u> Duration <u>10min</u>	Model _____
<input type="checkbox"/> Dresser	<input type="checkbox"/> Nitrogen	Serial _____
<input type="checkbox"/> Mag anode installed	<input type="checkbox"/> Hydrostatic	Valve ID _____
<input type="checkbox"/> Insert thru old pipe	<input checked="" type="checkbox"/> Soap test	Leak category <input type="checkbox"/> 1 <input type="checkbox"/> 2
<input checked="" type="checkbox"/> Boring tool used	Inspections:	<input type="checkbox"/> Bottle/bag sample taken
<input type="checkbox"/> Stub marker ball	<input type="checkbox"/> Radiography (X-ray) <input checked="" type="checkbox"/> Tracer wire continuity	Leak repair <input type="checkbox"/> Permanent <input type="checkbox"/> Temporary
	<input type="checkbox"/> NDI of welds <input type="checkbox"/> Other	

NON-MOBILE COMPLETION USERS ONLY

	Length (m)	Size (mm)	Material			
Extended past safe meter location			<input type="checkbox"/> PE	<input type="checkbox"/> ST		
Abandoned pipe			<input type="checkbox"/> PE	<input type="checkbox"/> ST		
Unit No. or address	FortisBC Meter No.	Manufacturer's No.	Dials	Reading	Del. Press	Reg tag
<input checked="" type="checkbox"/> Install	392	RLT1363954	4	φ	14	CP6048
<input type="checkbox"/> Remove						
<input type="checkbox"/> Reset						
<input type="checkbox"/> Install						
<input type="checkbox"/> Remove						
<input type="checkbox"/> Reset						

ID number  
4060

Completion date (Yr/Mo/Day)  
15/12/14

ATTENTION: DO NOT RELY ON THIS INFORMATION ALONE. You must manually dig to locate gas lines before using excavation machinery. All locations are shown approximate only & gas lines built after the date below are not in this information package. BC Gas will not accept responsibility for errors or omissions. Depth of gas line are not available due to possible change of grade.

T-DOC



Job number **30853387**

For office use only: **10052071001 - NEW**  
 Premise number:

Job address **406 CURTIS RD.**

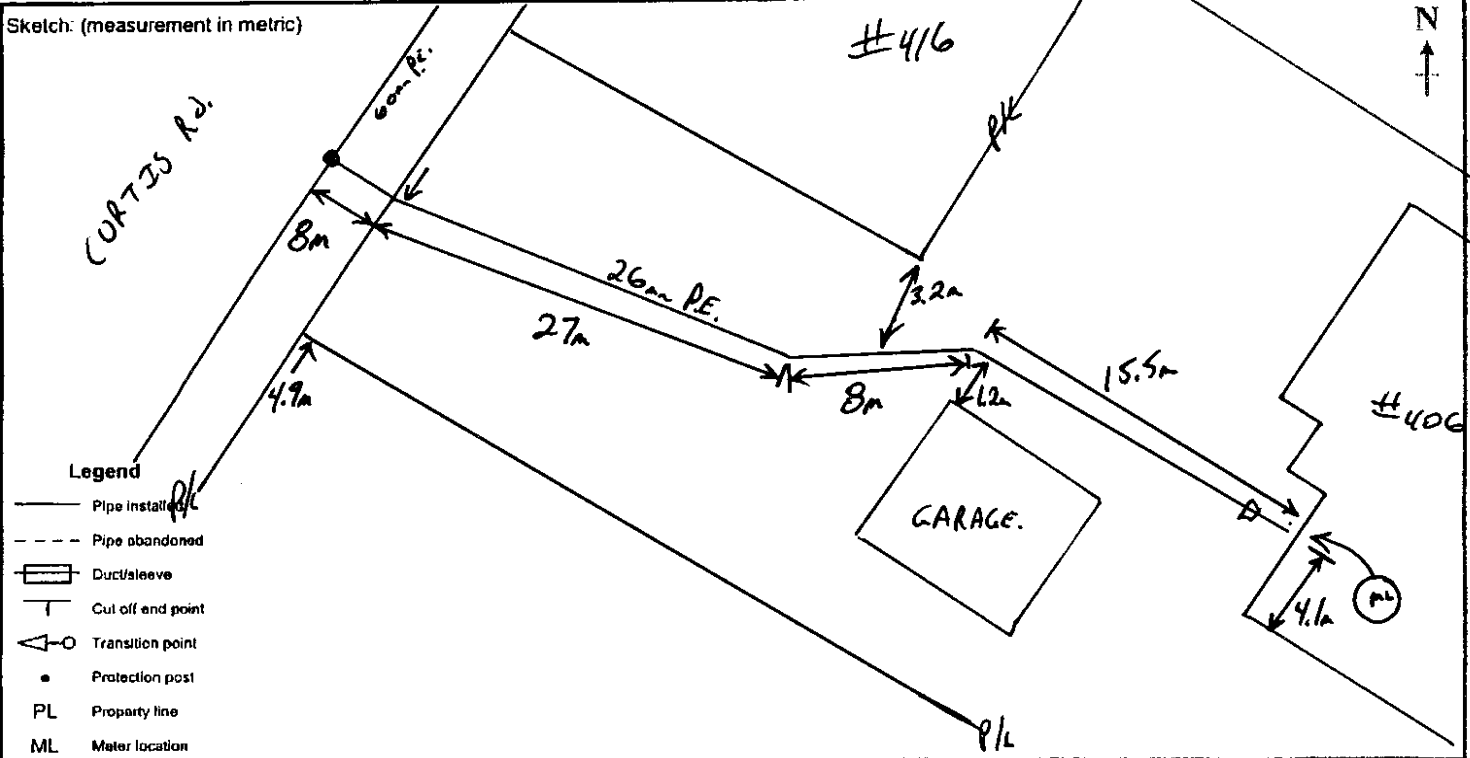

Description of work/additional comments:

- 58.5m OF 26mm P.E. SERVICE INSTALLED.  
 - COMMON DUY BELONGS TO #416. -EASEMENT FOR DUY ONLY.-

Customer trench	length (m)	Tie in method	<b>60x26mm P.T.T.</b>	Valve details:
Customer sleeve	length (m)	Depth of main (m)	<b>1.2</b>	New installs (mandatory) or Existing (if known)
Protection posts	quantity	Tap size (mm)	<b>19</b>	<input type="checkbox"/> Service valve <input type="checkbox"/> Main valve
Winter charges apply?	<input type="checkbox"/> Yes <input checked="" type="checkbox"/> No	Pressure test	Pressure (kPa) <b>800</b> Duration <b>10min</b>	Manufacturer
Snow shed	<input type="checkbox"/> Yes <input checked="" type="checkbox"/> No	<input checked="" type="checkbox"/> Air		Model
<input type="checkbox"/> Dresser		<input type="checkbox"/> Nitrogen		Serial
<input type="checkbox"/> Mag anode installed		<input type="checkbox"/> Hydrostatic		Valve ID
<input type="checkbox"/> Insert thru old pipe		<input checked="" type="checkbox"/> Soap test		Leak category <input type="checkbox"/> 1 <input type="checkbox"/> 2
<input type="checkbox"/> Boring tool used		Inspections:		<input type="checkbox"/> Bottle/bag sample taken
<input type="checkbox"/> Stub marker ball		<input type="checkbox"/> Radiography (X-ray)	<input checked="" type="checkbox"/> Tracer wire continuity	Leak repair <input type="checkbox"/> Permanent <input type="checkbox"/> Temporary
		<input type="checkbox"/> NDI of welds	<input type="checkbox"/> Other	

NON-MOBILE COMPLETION USERS ONLY

	Length (m)	Size (mm)	Material				
Extended past safe meter location	(m)	(mm)	<input type="checkbox"/> PE <input type="checkbox"/> ST				
Abandoned pipe	(m)	(mm)	<input type="checkbox"/> PE <input type="checkbox"/> ST				
Unit No. or address	FortisBC Meter No.	Manufacturer's No.	Dials	Reading	Del. Press	Reg tag	
<input checked="" type="checkbox"/> Install	<b>406</b>	<b>RCT1362373</b>	<b>19624373</b>	<b>4</b>	<b>Ø</b>	<b>14</b>	<b>CR 9413</b>
<input type="checkbox"/> Remove							
<input type="checkbox"/> Resel							
<input type="checkbox"/> Install							
<input type="checkbox"/> Remove							
<input type="checkbox"/> Resel							

ID number **4060**

**B. Miller**

Completion date (Y/M/D) **16/05/13**

ATTENTION: DO NOT RELY ON THIS INFORMATION ALONE. You must manually dig to locate gas lines before using excavation machinery. All locations are shown approximate only & gas lines built after the date below are not in this information package. BC Gas will not accept responsibility for errors or omissions. Depth of gas line are not available due to possible change of grade.

T-DOC



Job number  
30821067

For office use only:  
Premise number: 10045982001 - New

Job address  
413 CURTIS RD.

COMOX

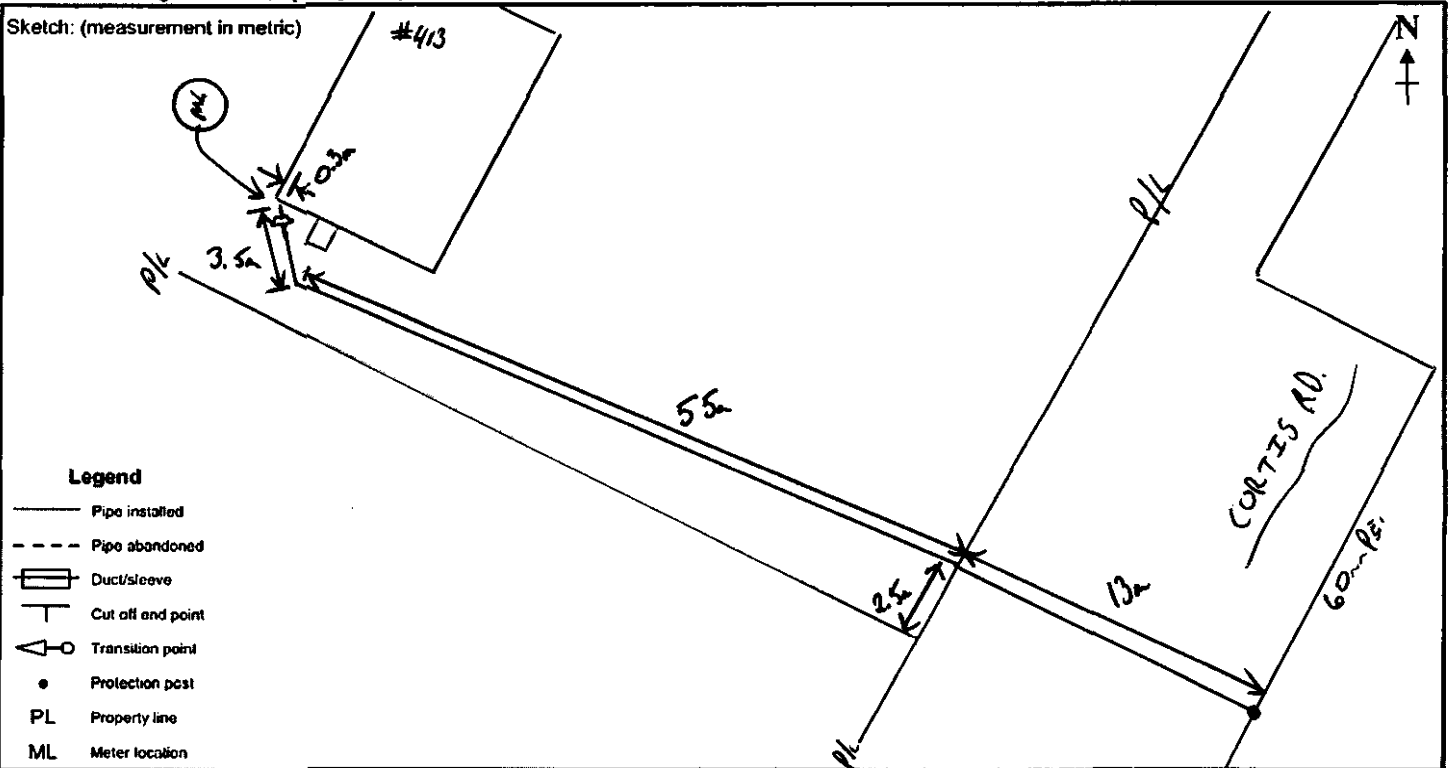

Description of work/additional comments:  
71.5m OF 26m PE SERVICE INSTALLED

Customer trench	length (m)	Tie in method	60x26m E.F.T.	Valve details:
Customer sleeve	length (m)	Depth of main (m)	1.2	New Installs (mandatory) or Existing (if known)
Protection posts	quantity	Tap size (mm)	19	<input type="checkbox"/> Service valve <input type="checkbox"/> Main valve
Winter charges apply?	<input type="checkbox"/> Yes <input checked="" type="checkbox"/> No	Pressure test	Pressure (kPa)	Manufacturer
Snow shed	<input type="checkbox"/> Yes <input checked="" type="checkbox"/> No	<input checked="" type="checkbox"/> Air	800	Model
<input type="checkbox"/> Dresser		<input type="checkbox"/> Nitrogen		Serial
<input type="checkbox"/> Mag anode installed		<input type="checkbox"/> Hydrostatic		Valve ID
<input type="checkbox"/> Insert thru old pipe		<input checked="" type="checkbox"/> Soap test	Duration	Leak category <input type="checkbox"/> 1 <input type="checkbox"/> 2
<input checked="" type="checkbox"/> Boring tool used		<b>Inspections:</b>	10min	<input type="checkbox"/> Bottle/bag sample taken
<input type="checkbox"/> Stub marker ball		<input type="checkbox"/> Radiography (X-ray)		Leak repair <input type="checkbox"/> Permanent <input type="checkbox"/> Temporary
		<input checked="" type="checkbox"/> Tracer wire continuity		
		<input type="checkbox"/> NDI of welds		
		<input type="checkbox"/> Other		

NON-MOBILE COMPLETION USERS ONLY

Length	Size	Material							
Extended past safe meter location (m)	(mm)	<input type="checkbox"/> PE <input type="checkbox"/> ST	Unit No. or address	FortisBC Meter No.	Manufacturer's No.	Dials	Reading	Del. Press	Reg tag
Abandoned pipe (m)	(mm)	<input type="checkbox"/> PE <input type="checkbox"/> ST							
			413	RCT1362423	19624423	4	∅	14	EF 5307

ID number  
4060    B. Miller

Completion date (Yr. Mo./Day)  
16/03/09

ATTENTION: DO NOT RELY ON THIS INFORMATION ALONE. You must manually dig to locate gas lines before using excavation machinery. All locations are shown approximate only & gas lines built after the date below are not in this information package. BC Gas will not accept responsibility for errors or omissions. Depth of gas line are not available due to possible change of grade.

T-DOC



Job number  
30850043

For office use only:  
Premise number: 10051319001-NEW

Job address  
416 CURTIS RD. COMOX

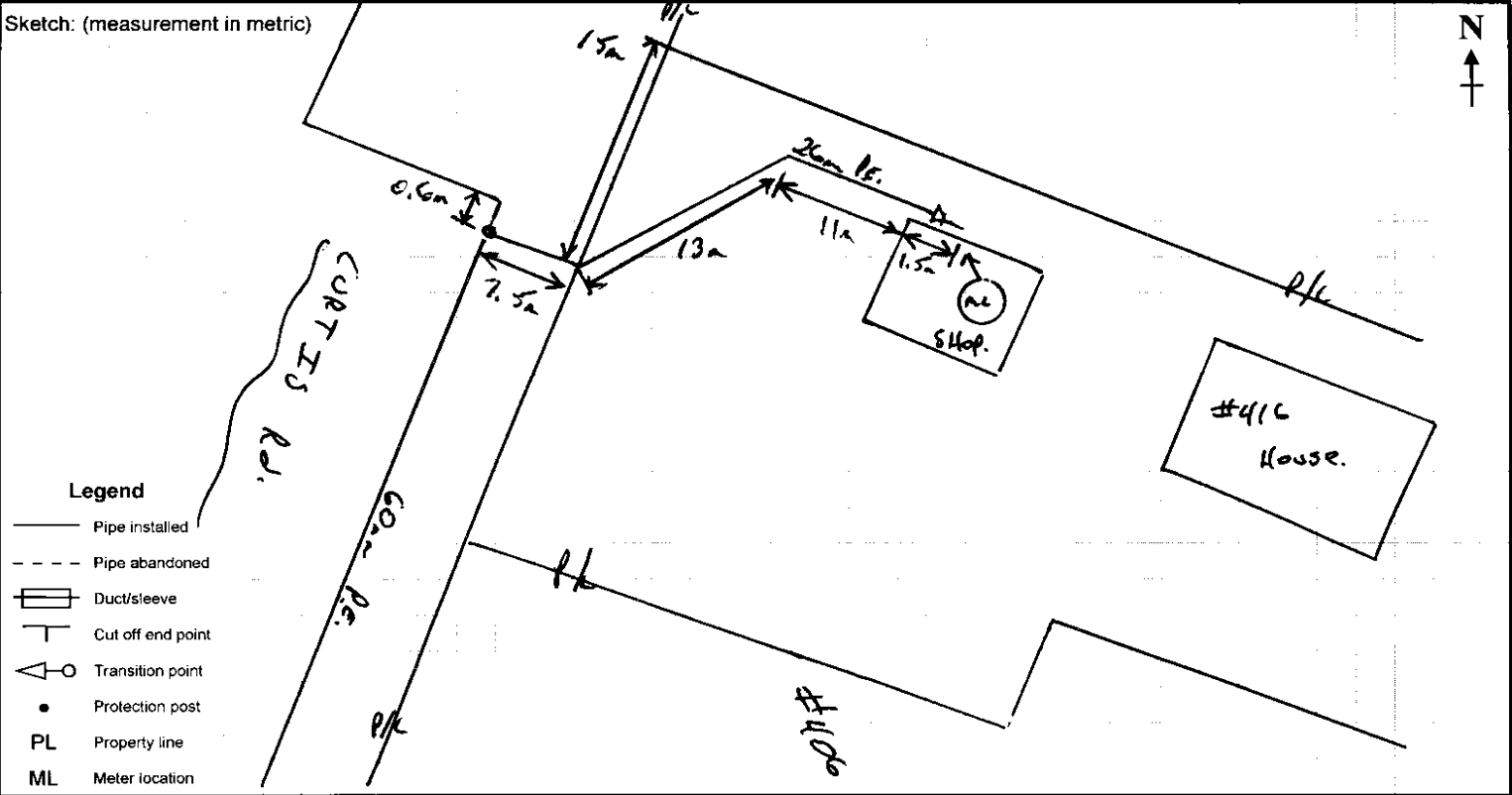

Description of work/additional comments:  
33 m OF 26mm P.E. SERVICE INSTALLED

Customer trench _____ length (m)	Tie in method <u>60x26mm P.T.T.</u>	Valve details:
Customer sleeve _____ length (m)	Depth of main (m) <u>1</u>	New Installs (mandatory) or Existing (if known)
Protection posts _____ quantity	Tap size (mm) <u>19</u>	<input type="checkbox"/> Service valve <input type="checkbox"/> Main valve
Winter charges apply? <input type="checkbox"/> Yes <input checked="" type="checkbox"/> No	Pressure test	Manufacturer _____
Snow shed <input type="checkbox"/> Yes <input checked="" type="checkbox"/> No	<input checked="" type="checkbox"/> Air      Pressure (kPa) <u>800</u> Duration <u>10min</u>	Model _____
<input type="checkbox"/> Dresser	<input type="checkbox"/> Nitrogen	Serial _____
<input type="checkbox"/> Mag anode installed	<input type="checkbox"/> Hydrostatic	Valve ID _____
<input type="checkbox"/> Insert thru old pipe	<input type="checkbox"/> Soap test	Leak category <input type="checkbox"/> 1 <input type="checkbox"/> 2
<input type="checkbox"/> Boring tool used	Inspections:	<input type="checkbox"/> Bottle/bag sample taken
<input type="checkbox"/> Stub marker ball	<input type="checkbox"/> Radiography (X-ray) <input type="checkbox"/> Tracer wire continuity	Leak repair <input type="checkbox"/> Permanent <input type="checkbox"/> Temporary
	<input type="checkbox"/> NDI of welds <input type="checkbox"/> Other	

NON-MOBILE COMPLETION USERS ONLY

	Length (m)	Size (mm)	Material				
Extended past safe meter location	(m)	(mm)	<input type="checkbox"/> PE	<input type="checkbox"/> ST			
Abandoned pipe	(m)	(mm)	<input type="checkbox"/> PE	<input type="checkbox"/> ST			
Unit No. or address	FortisBC Meter No.	Manufacturer's No.	Dials	Reading	Del. Press	Reg tag	
<input checked="" type="checkbox"/> Install	416	RCT1387885	4	Ø	14	EF10673	
<input type="checkbox"/> Remove							
<input type="checkbox"/> Reset							
<input type="checkbox"/> Install							
<input type="checkbox"/> Remove							
<input type="checkbox"/> Reset							

ID number 4060      B. Miller      Completion date (Yr/Mth/Day) 16/06/10

ATTENTION: DO NOT RELY ON THIS INFORMATION ALONE. You must manually dig to locate gas lines before using excavation machinery. All locations are shown approximate only & gas lines built after the date below are not in this information package. BC Gas will not accept responsibility for errors or omissions. Depth of gas line are not available due to possible change of grade.

T-DOC



Job number 3082 5214

For office use only: Premise number: 10046896001 - New

Job address 430 CURTIS RD.

COMOX

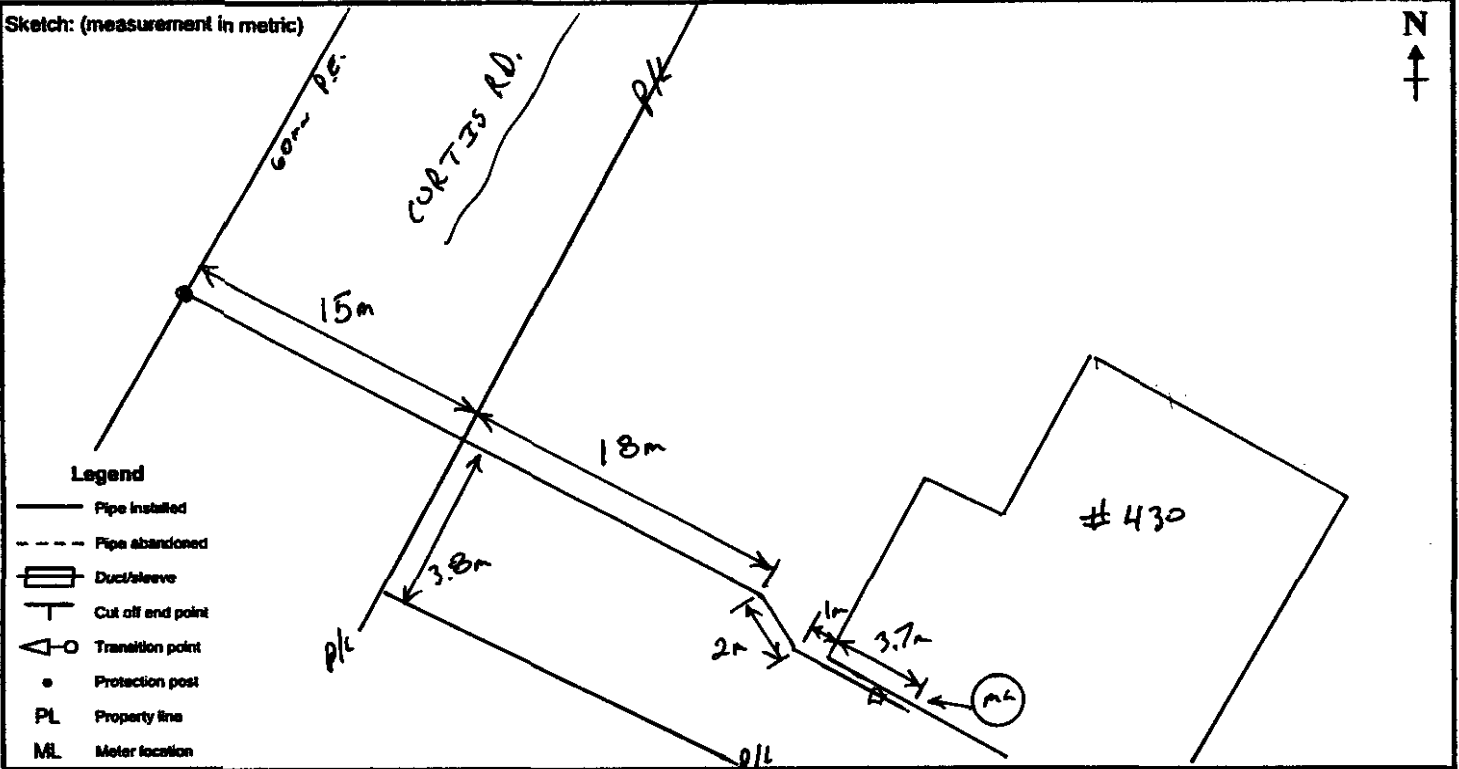

Description of work/additional comments:

39.7 m OF 26mm P.E. SERVICE INSTALLED.

JCR#65399

Customer trench length (m)		Tie in method	60x26mm P.T.T.	Valve details:	
Customer sleeve length (m)		Depth of main (m)	1.2	New Installs (mandatory) or Existing (if known)	<input type="checkbox"/> Service valve <input type="checkbox"/> Main valve
Protection posts quantity		Tap size (mm)	19	Manufacturer	
Winter charges apply? <input type="checkbox"/> Yes <input checked="" type="checkbox"/> No		Pressure test	Pressure (kPa) 8.00	Model	
Snow shed <input type="checkbox"/> Yes <input checked="" type="checkbox"/> No		<input checked="" type="checkbox"/> Air	Duration 10min	Serial	
<input type="checkbox"/> Dresser		<input type="checkbox"/> Nitrogen		Valve ID	
<input type="checkbox"/> Mag anode installed		<input type="checkbox"/> Hydrostatic		Leak category <input type="checkbox"/> 1 <input type="checkbox"/> 2	
<input type="checkbox"/> Insert thru old pipe		<input checked="" type="checkbox"/> Soap test		<input type="checkbox"/> Bottle/bag sample taken	
<input type="checkbox"/> Boring tool used		Inspections:		Leak repair <input type="checkbox"/> Permanent <input type="checkbox"/> Temporary	
<input type="checkbox"/> Stub marker ball		<input type="checkbox"/> Radiography (X-ray)	<input checked="" type="checkbox"/> Tracer wire continuity		
		<input type="checkbox"/> NDI of welds	<input type="checkbox"/> Other		

NON-MOBILE COMPLETION USERS ONLY

	Length (m)	Size (mm)	Material
Extended past safe meter location			<input type="checkbox"/> PE <input type="checkbox"/> ST
Abandoned pipe			<input type="checkbox"/> PE <input type="checkbox"/> ST

	Unit No. or address	FortisBC Meter No.	Manufacturer's No.	Dials	Reading	Del. Press	Reg tag
<input checked="" type="checkbox"/> Install	430	RCT1363956	19625956	4	Ø	14	CP6661
<input type="checkbox"/> Remove							
<input type="checkbox"/> Reset							
<input type="checkbox"/> Install							
<input type="checkbox"/> Remove							
<input type="checkbox"/> Reset							

ID number 4060

Completion date (Yr/Mth/Day) 15/12/15

SENT TO CMO FOR CHANGE OF LOT (M)

ATTENTION: DO NOT RELY ON THIS INFORMATION ALONE. You must manually dig to locate gas lines before using excavation machinery. All locations are shown approximate only & gas lines built after the date below are not in this information package. BC Gas will not accept responsibility for errors or omissions. Depth of gas line are not available due to possible change of grade.

*11211*  
**100-96047001**



**T-DOC**

Job Number **30821346** Job address **433 CURTIS RD. COMOX**

Location/description of work/additional comments  
**26m OF 26mm P.E. SERVICE INSTALLED.**

**- JOMAR VALVE INSTALLED**

Service Pipe	Length (m)	Size (mm)	Material
Main to PL	4.5	26	<input checked="" type="checkbox"/> PE <input type="checkbox"/> ST
PL to safe meter location (per code)	21.5	26	<input checked="" type="checkbox"/> PE <input type="checkbox"/> ST
Extended past safe meter location (per customer)			<input type="checkbox"/> PE <input type="checkbox"/> ST
<b>Total Service Length</b>	<b>26</b>	Main to meter location	
Riser (vertical)	0.9	15	<input checked="" type="checkbox"/> PE <input type="checkbox"/> ST

Service cut off at:  
 Main  Inside PL  Outside PL  
 At PL  At HDR  Other \_\_\_\_\_  
 Abandoned pipe \_\_\_\_\_ (m) \_\_\_\_\_ (mm)  
 Length \_\_\_\_\_ Size \_\_\_\_\_  
 Material  PE  ST  
 Stub marker ball

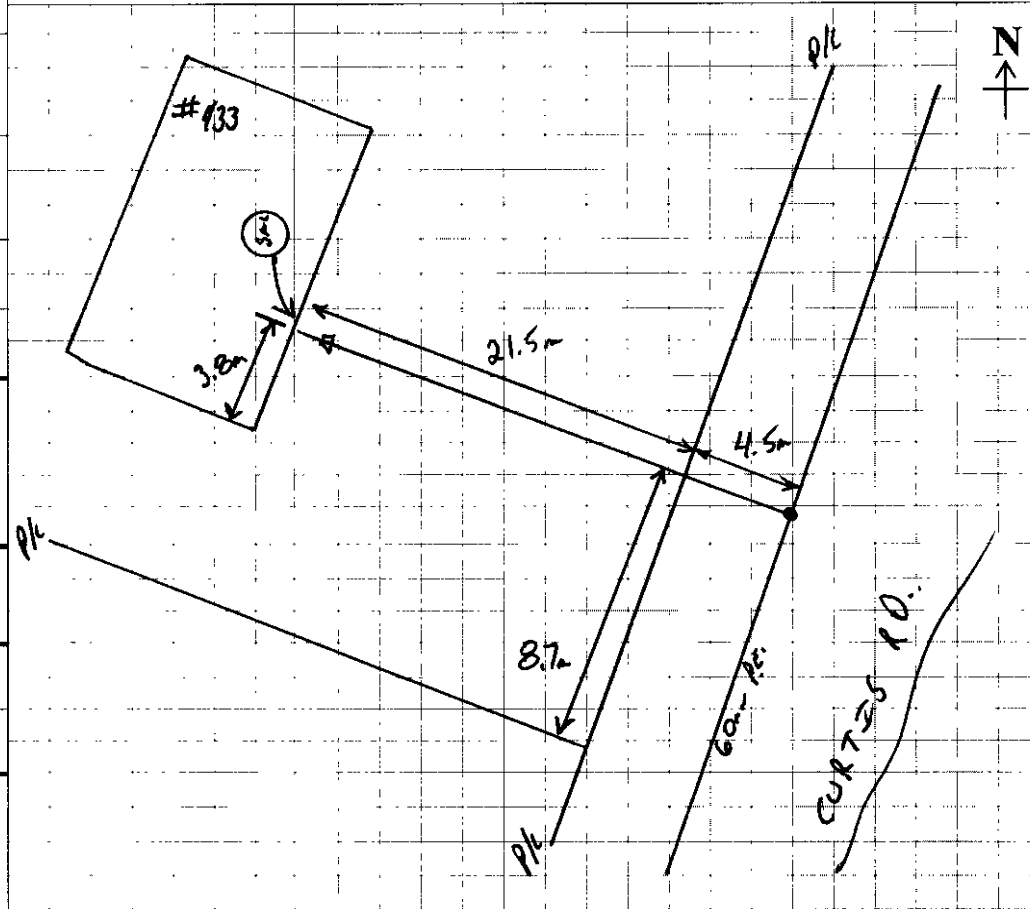

Customer trench \_\_\_\_\_ Length (m)  
 Customer sleeve \_\_\_\_\_ Length (m)  
 Protection posts \_\_\_\_\_ Quantity  
 Winter charges apply?  Yes  No  
 Snow shed  Yes  No

Service Valve  Dresser  
 Mag anode installed  Flex hose  
 Undergrnd house lines  Insert thru old pipe

Tie in method  
**60x26mm P.T.T.**  
 Depth (m) **1.2** Tap Size (mm) **19**

Test Method Pressure (kPa) Duration  
 Air **800** **10min**  
 Nitrogen \_\_\_\_\_  
 Soap test  Radiography (X-ray)  
 Tracer wire continuity  
 Other \_\_\_\_\_

Service location is **8.7** meters (direction) **NORTH** from **SOUTH P/L**

Meter location  Left -hand side  Right-hand side  
 Front left  Front right  
 Remote  Back left  Back right  
 Leak category  1  2  3  
 Leak repair  Permanent  Temporary  
 Leak check  Odor recheck  Bottle/bag sample taken

	Unit No. or Address	FortisBC Meter No.	Manufacturer's No.	Dials	Reading	Del. Press	PFM Number
<input checked="" type="checkbox"/> Install <input type="checkbox"/> Remove <input type="checkbox"/> Reset	<b>433</b>	<b>RCT1364004</b>	<b>19626004</b>	<b>4</b>	<b>0</b>	<b>14</b>	<b>CP6620</b>
<input type="checkbox"/> Install <input type="checkbox"/> Remove <input type="checkbox"/> Reset							

Scheduling  
 Customer contacted  Left message  
 Date contacted (Yr/Mth/Day) **15/11/26** Rescheduled date (Yr/Mth/Day) \_\_\_\_\_

Estimated additional charges  
 No add. charges  Unable to contact cust  
 Customer notified of additional charges  
 Customer approved additional charges

Crew sign off  
 FortisBC  Contractor  
 I hereby certify that the work was completed in accordance with the company standard practices.  
**B. Miller** **Brian Miller**  
 Crew leader (PRINT) Crew leader signature

Notes  
**JCR # 65646**

Customer name \_\_\_\_\_  
 Total estimated additional charges \$ \_\_\_\_\_

ID number **4060** Date (Yr/Mth/Day) **15/11/27**



ATTENTION: DO NOT RELY ON THIS INFORMATION ALONE. You must manually dig to locate gas lines before using excavation machinery. All locations are shown approximate only & gas lines built after the date below are not in this information package. BC Gas will not accept responsibility for errors or omissions. Depth of gas line are not available due to possible change of grade.

T-DOC



Job number **3082 1093**

For office use only: Premise number: **10045989001 - NEW**

Job address **442 CURTIS RD. COMOX.**

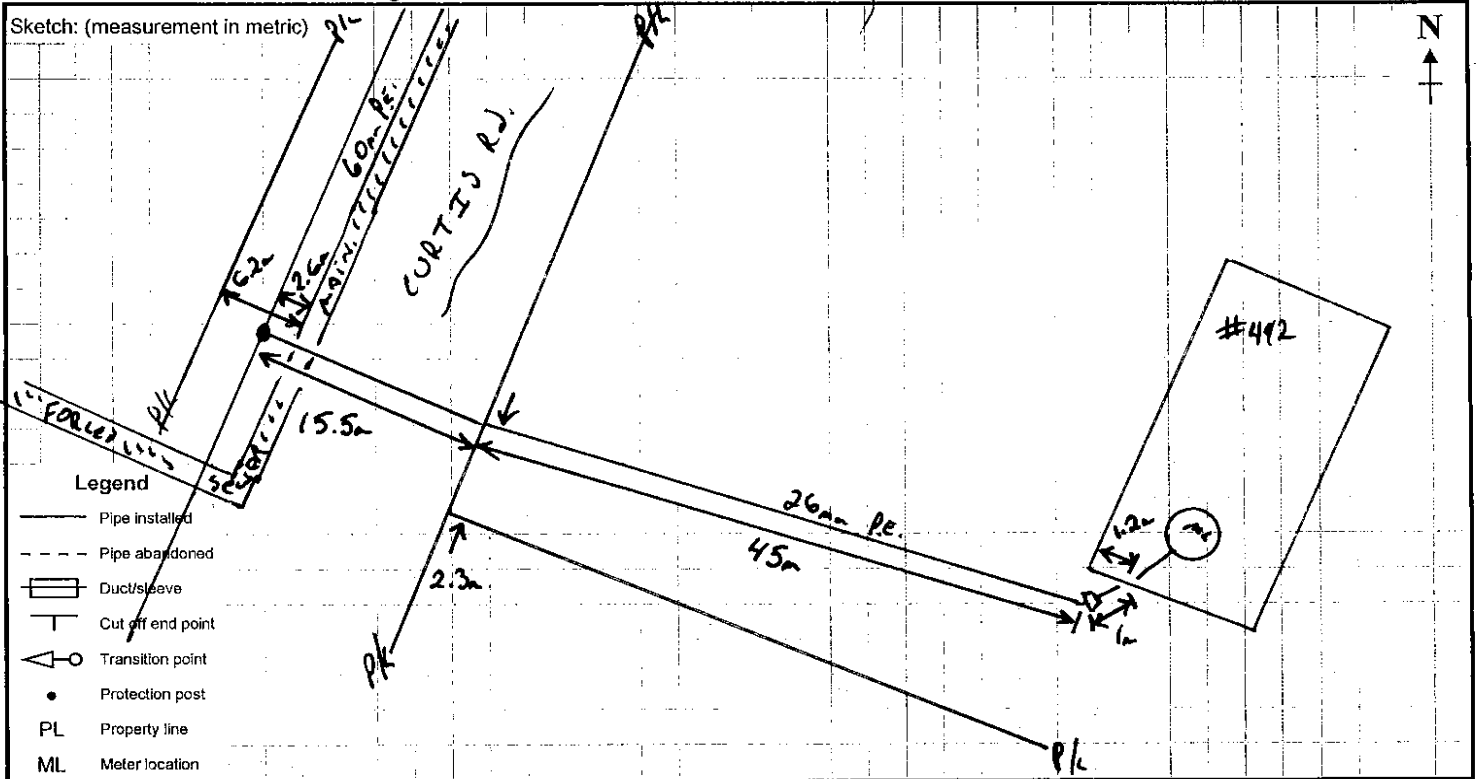

Description of work/additional comments:  
**61.5m OF 26mm PE SERVICE INSTALLED. GAS SERVICE GOES OVER TOP OF FORCED SEWER MAIN.**

Customer trench _____ length (m)	Tie in method <b>60x26mm P.T.T.</b>	Valve details:
Customer sleeve _____ length (m)	Depth of main (m) <b>1.0</b>	New Installs (mandatory) or Existing (if known)
Protection posts _____ quantity	Tap size (mm) <b>19</b>	<input type="checkbox"/> Service valve <input type="checkbox"/> Main valve
Winter charges apply? <input type="checkbox"/> Yes <input checked="" type="checkbox"/> No	Pressure test	Manufacturer _____
Snow shed <input type="checkbox"/> Yes <input checked="" type="checkbox"/> No	<input checked="" type="checkbox"/> Air <b>800</b> <b>10min</b>	Model _____
<input type="checkbox"/> Dresser	<input type="checkbox"/> Nitrogen	Serial _____
<input type="checkbox"/> Mag anode installed	<input type="checkbox"/> Hydrostatic	Valve ID _____
<input type="checkbox"/> Insert thru old pipe	<input checked="" type="checkbox"/> Soap test	Leak category <input type="checkbox"/> 1 <input type="checkbox"/> 2
<input type="checkbox"/> Boring tool used	Inspections:	<input type="checkbox"/> Bottle/bag sample taken
<input type="checkbox"/> Stub marker ball	<input type="checkbox"/> Radiography (X-ray) <input checked="" type="checkbox"/> Tracer wire continuity	Leak repair <input type="checkbox"/> Permanent <input type="checkbox"/> Temporary
	<input type="checkbox"/> NDI of welds <input type="checkbox"/> Other	

NON-MOBILE COMPLETION USERS ONLY

	Length (m)	Size (mm)	Material				
Extended past safe meter location	(m)	(mm)	<input type="checkbox"/> PE	<input type="checkbox"/> ST			
Abandoned pipe	(m)	(mm)	<input type="checkbox"/> PE	<input type="checkbox"/> ST			
Unit No. or address	FortisBC Meter No.	Manufacturer's No.	Dials	Reading	Del. Press	Reg tag	
<input checked="" type="checkbox"/> Install <input type="checkbox"/> Remove <input type="checkbox"/> Reset	<b>442</b>	<b>RCT1362360</b>	<b>19624360</b>	<b>4</b>	<b>φ</b>	<b>14</b>	<b>CR 9410</b>
<input type="checkbox"/> Install <input type="checkbox"/> Remove <input type="checkbox"/> Reset							

ID number **4060** **B. Miller**

Completion date (Yr/Mth/Day) **16/05/16**

ATTENTION: DO NOT RELY ON THIS INFORMATION ALONE. You must manually dig to locate gas lines before using excavation machinery. All locations are shown approximate only & gas lines built after the date below are not in this information package. BC Gas will not accept responsibility for errors or omissions. Depth of gas line are not available due to possible change of grade.

T-DOC



Job number  
30856812

For office use only:  
Premise number: 10052924001 - New

Job address  
448 CURTIS RD.

COMOX

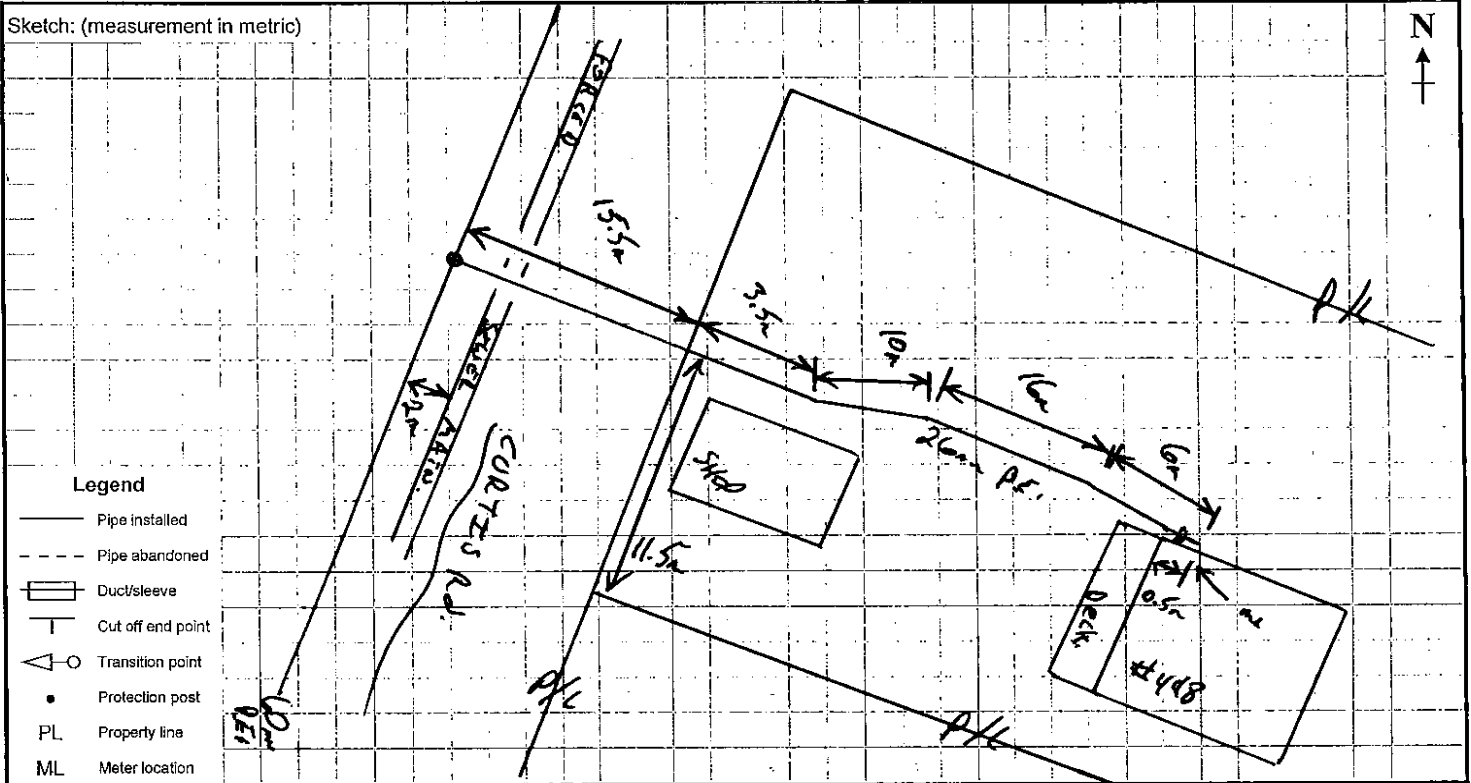

Description of work/additional comments:

51A OF 26mm P.E. SERVICE INSTALLED.

Customer trench _____ length (m)	Tie in method <u>60x26mm w P.T.C.</u>	Valve details:
Customer sleeve _____ length (m)	Depth of main (m) <u>0.12m</u>	New Installs (mandatory) or Existing (if known)
Protection posts _____ quantity	Tap size (mm) <u>19</u>	<input type="checkbox"/> Service valve <input type="checkbox"/> Main valve
Winter charges apply? <input type="checkbox"/> Yes <input checked="" type="checkbox"/> No	Pressure test	Manufacturer _____
Snow shed <input type="checkbox"/> Yes <input checked="" type="checkbox"/> No	<input checked="" type="checkbox"/> Air Pressure (kPa) <u>900</u> Duration <u>10min</u>	Model _____
<input type="checkbox"/> Dresser	<input type="checkbox"/> Nitrogen	Serial _____
<input type="checkbox"/> Mag anode installed	<input type="checkbox"/> Hydrostatic	Valve ID _____
<input type="checkbox"/> Insert thru old pipe	<input checked="" type="checkbox"/> Soap test	Leak category <input type="checkbox"/> 1 <input type="checkbox"/> 2
<input type="checkbox"/> Boring tool used	Inspections:	<input type="checkbox"/> Bottle/bag sample taken
<input type="checkbox"/> Stub marker ball	<input type="checkbox"/> Radiography (X-ray) <input type="checkbox"/> Tracer wire continuity	Leak repair <input type="checkbox"/> Permanent <input type="checkbox"/> Temporary
	<input type="checkbox"/> NDI of welds <input type="checkbox"/> Other	

NON-MOBILE COMPLETION USERS ONLY

Extended past safe meter location	Length (m)	Size (mm)	Material				
Abandoned pipe	(m)	(mm)	<input type="checkbox"/> PE	<input type="checkbox"/> ST			
			<input type="checkbox"/> PE	<input type="checkbox"/> ST			
Unit No. or address	FortisBC Meter No.	Manufacturer's No.	Dials	Reading	Del. Press	Reg tag	
<input checked="" type="checkbox"/> Install							
<input type="checkbox"/> Remove							
<input type="checkbox"/> Reset							
<input type="checkbox"/> Install							
<input type="checkbox"/> Remove							
<input type="checkbox"/> Reset							
448	RCT1387376	20052376	4	∅	14	CF. 9840	

ID number  
4060

B. Miller

Completion date (Yr/Mth/Day)  
16/06/28

ATTENTION: DO NOT RELY ON THIS INFORMATION ALONE. You must manually dig to locate gas lines before using excavation machinery. All locations are shown approximate only & gas lines built after the date below are not in this information package. BC Gas will not accept responsibility for errors or omissions. Depth of gas line are not available due to possible change of grade.

T-DOC



Job number  
30823710

For office use only:  
Premise number: 100466006001

Job address  
461 CURTIS RD.

COMOX

NEW

Sketch: (measurement in metric)

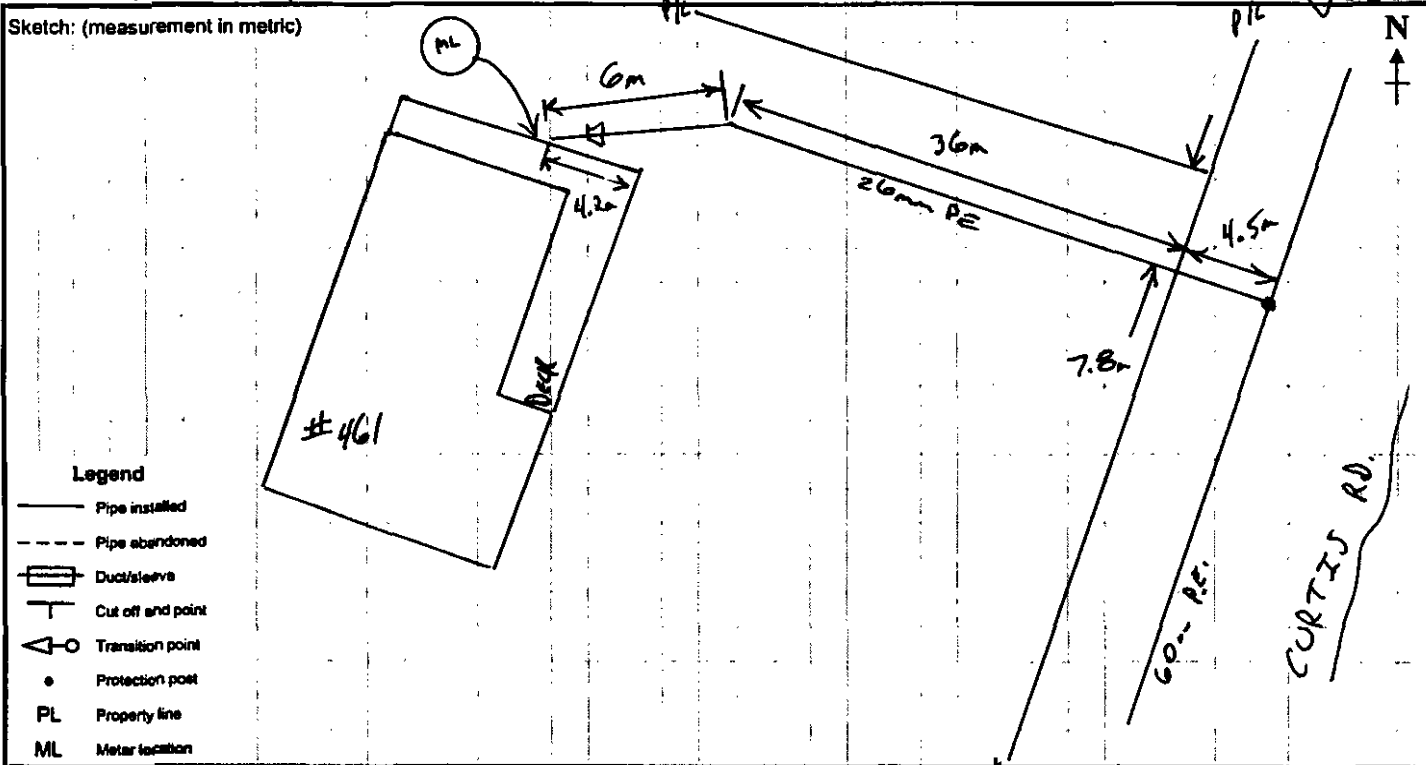

Description of work/additional comments:  
46.5m OF 26mm P.E. SERVICE INSTALLED.

SCR# 65396

Customer trench _____ length (m)	Tie in method <u>60 X 26mm P.T.T.</u>	Valve details:
Customer sleeve _____ length (m)	Depth of main (m) <u>1.2</u>	New installs (mandatory) or Existing (if known)
Protection posts _____ quantity	Tap size (mm) <u>19</u>	<input type="checkbox"/> Service valve <input type="checkbox"/> Main valve
Winter charges apply? <input type="checkbox"/> Yes <input checked="" type="checkbox"/> No	Pressure test	Manufacturer _____
Snow shed <input type="checkbox"/> Yes <input checked="" type="checkbox"/> No	<input checked="" type="checkbox"/> Air <u>800</u> <u>10min</u>	Model _____
<input type="checkbox"/> Dresser	<input type="checkbox"/> Nitrogen	Serial _____
<input type="checkbox"/> Mag anode installed	<input type="checkbox"/> Hydrostatic	Valve ID _____
<input type="checkbox"/> Insert thru old pipe	<input checked="" type="checkbox"/> Soap test	Leak category <input type="checkbox"/> 1 <input type="checkbox"/> 2
<input checked="" type="checkbox"/> Boring tool used	Inspections:	<input type="checkbox"/> Bottle/bag sample taken
<input type="checkbox"/> Stub marker ball	<input type="checkbox"/> Radiography (X-ray) <input checked="" type="checkbox"/> Tracer wire continuity	Leak repair <input type="checkbox"/> Permanent <input type="checkbox"/> Temporary
	<input type="checkbox"/> NDI of welds <input type="checkbox"/> Other	

NON-MOBILE COMPLETION USERS ONLY

Extended past safe meter location	Length (m)	Size (mm)	Material <input type="checkbox"/> PE <input type="checkbox"/> ST
Abandoned pipe	(m)	(mm)	<input type="checkbox"/> PE <input type="checkbox"/> ST

	Unit No. or address	FortisBC Meter No.	Manufacturer's No.	Dials	Reading	Del. Press	Reg tag
<input checked="" type="checkbox"/> Install	461	RCT1363970	19625970	4	Φ	14	EF 1007
<input type="checkbox"/> Remove							
<input type="checkbox"/> Reset							
<input type="checkbox"/> Install							
<input type="checkbox"/> Remove							
<input type="checkbox"/> Reset							

ID number  
4060

Completion date (Y/M/D)  
15/12/11

ATTENTION: DO NOT RELY ON THIS INFORMATION ALONE. You must manually dig to locate gas lines before using excavation machinery. All locations are shown approximate only & gas lines built after the date below are not in this information package. BC Gas will not accept responsibility for errors or omissions. Depth of gas line are not available due to possible change of grade.

T-DOC



Job number: **30821075**  
 Job address: **476 CURTIS RD COMOX B.C.**  
 For office use only: Premise number: **10045984001**  
 INSTALL 25.9 OF 26 mm / 15 mm PE.

Sketch: (measurement in metric)

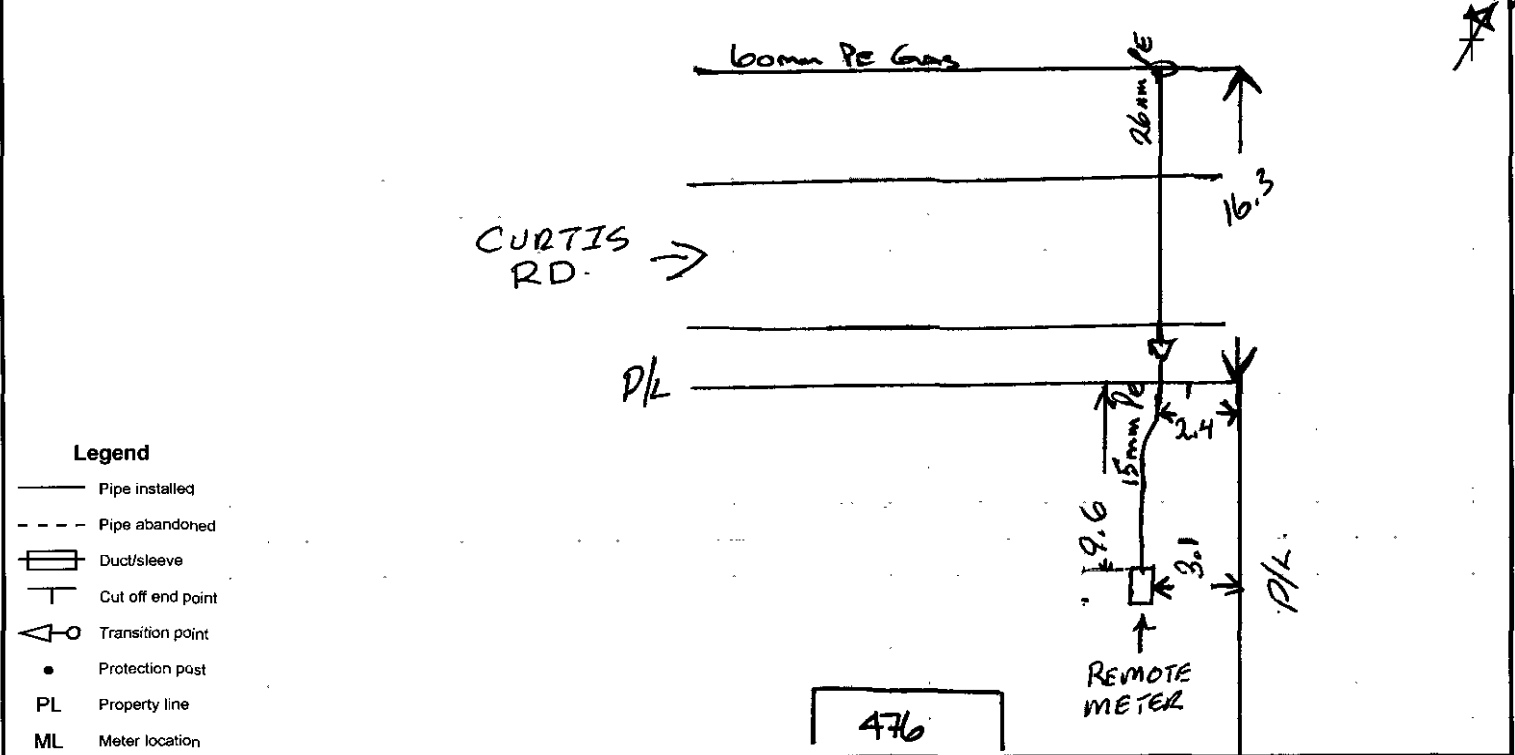

Legend

- Pipe installed
- - - Pipe abandoned
- ▭ Duct/sleeve
- ⊥ Cut off end point
- ◁○ Transition point
- Protection post
- PL Property line
- ML Meter location

Description of work/additional comments:

**25.9m OF SERVICE LINE INSTALLED FROM MAIN ACROSS CURTIS R.D.**

Customer trench	length (m)	Tie in method	Valve details:
Customer sleeve	length (m)	Depth of main (m)	New Installs (mandatory) or Existing (if known)
Protection posts	quantity	Tap size (mm)	<input type="checkbox"/> Service valve <input type="checkbox"/> Main valve
Winter charges apply?	<input type="checkbox"/> Yes <input checked="" type="checkbox"/> No	Pressure test	Manufacturer
Snow shed	<input type="checkbox"/> Yes <input checked="" type="checkbox"/> No	<input checked="" type="checkbox"/> Air	Model
<input type="checkbox"/> Dresser		<input type="checkbox"/> Nitrogen	Serial
<input type="checkbox"/> Mag anode installed		<input type="checkbox"/> Hydrostatic	Valve ID
<input type="checkbox"/> Insert thru old pipe		<input checked="" type="checkbox"/> Soap test	Leak category <input type="checkbox"/> 1 <input type="checkbox"/> 2
<input checked="" type="checkbox"/> Boring tool used		Inspections:	<input type="checkbox"/> Bottle/bag sample taken
<input type="checkbox"/> Stub marker ball		<input type="checkbox"/> Radiography (X-ray)	Leak repair <input type="checkbox"/> Permanent <input type="checkbox"/> Temporary
		<input checked="" type="checkbox"/> Tracer wire continuity	
		<input type="checkbox"/> NDI of welds	
		<input type="checkbox"/> Other	

NON-MOBILE COMPLETION USERS ONLY

	Length	Size	Material
Extended past safe meter location	(m)	(mm)	<input type="checkbox"/> PE <input type="checkbox"/> ST
Abandoned pipe	(m)	(mm)	<input type="checkbox"/> PE <input type="checkbox"/> ST
Unit No. or address	FortisBC Meter No.	Manufacturer's No.	Dials    Reading    Del. Press    Reg tag
<input checked="" type="checkbox"/> Install	<b>476 CURTIS RD</b>	<b>RCT 1362814</b>	<b>19624814</b>
<input type="checkbox"/> Remove			<b>4    0    14KPA    FF 3794</b>
<input type="checkbox"/> Reset			
<input type="checkbox"/> Install			
<input type="checkbox"/> Remove			
<input type="checkbox"/> Reset			

ID number: \_\_\_\_\_ Completion date (Yr/Mth/Day): **January 18/2016**

ATTENTION: DO NOT RELY ON THIS INFORMATION ALONE. You must manually dig to locate gas lines before using excavation machinery. All locations are shown approximate only & gas lines built after the date below are not in this information package. BC Gas will not accept responsibility for errors or omissions. Depth of gas line are not available due to possible change of grade.

T-DOC



Job number **30850099** For office use only: Premise number: **10051330001 - NEW**

Job address **490 CURTIS RD. COMOX**

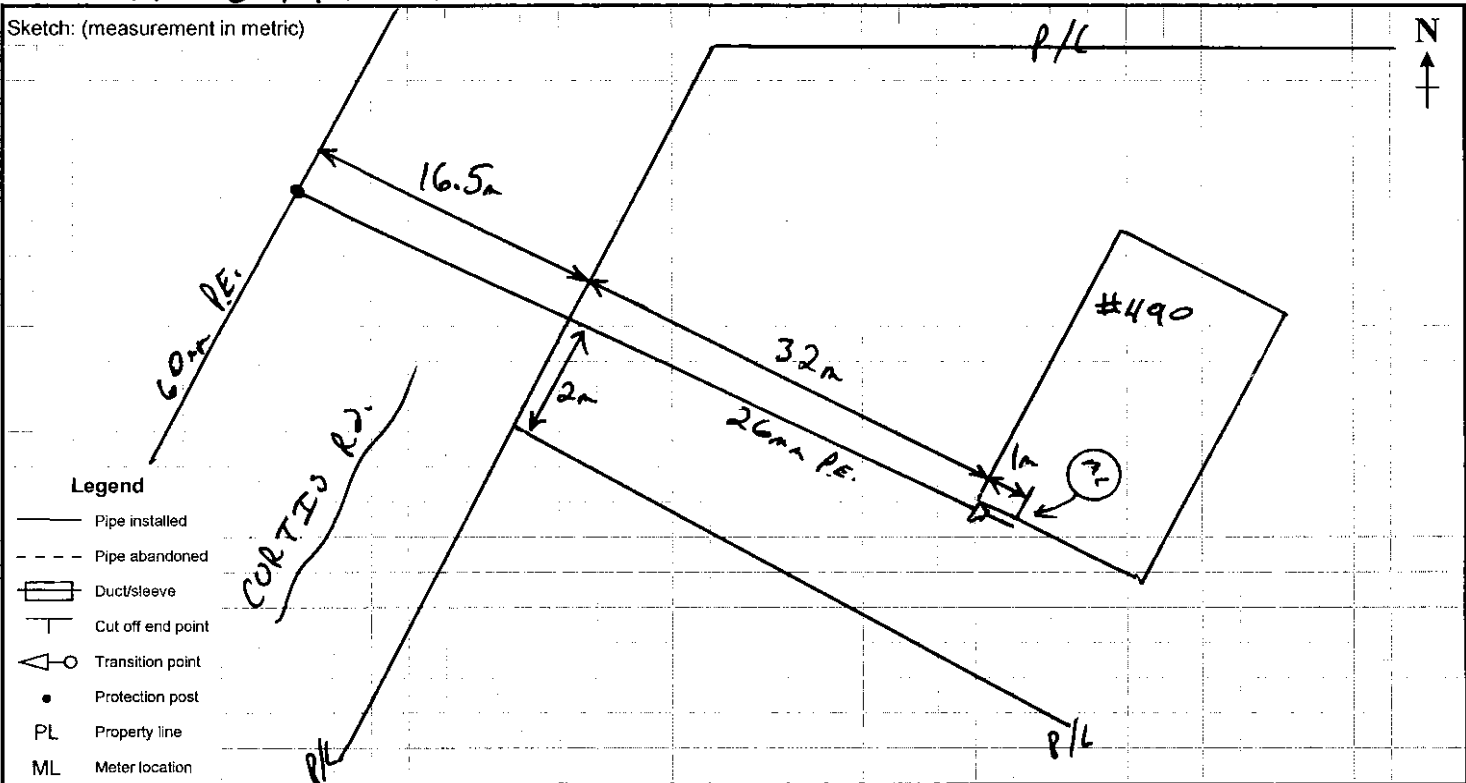

Description of work/additional comments: **49.5m OF 26mm PE. SERVICE INSTALLED.**

Customer trench <input checked="" type="checkbox"/> length (m)	Tie in method <b>60x26mm P.T.T.</b>	Valve details:
Customer sleeve <input checked="" type="checkbox"/> length (m)	Depth of main (m) <b>1.2</b>	New Installs (mandatory) or Existing (if known)
Protection posts <input checked="" type="checkbox"/> quantity	Tap size (mm) <b>19</b>	<input type="checkbox"/> Service valve <input type="checkbox"/> Main valve
Winter charges apply? <input type="checkbox"/> Yes <input checked="" type="checkbox"/> No	Pressure test	Manufacturer
Snow shed <input type="checkbox"/> Yes <input checked="" type="checkbox"/> No	<input checked="" type="checkbox"/> Air <b>800</b> <b>10min</b>	Model
<input type="checkbox"/> Dresser	<input type="checkbox"/> Nitrogen	Serial
<input type="checkbox"/> Mag anode installed	<input type="checkbox"/> Hydrostatic	Valve ID
<input type="checkbox"/> Insert thru old pipe	<input checked="" type="checkbox"/> Soap test	Leak category <input type="checkbox"/> 1 <input type="checkbox"/> 2
<input type="checkbox"/> Boring tool used	Inspections:	<input type="checkbox"/> Bottle/bag sample taken
<input type="checkbox"/> Stub marker ball	<input type="checkbox"/> Radiography (X-ray) <input type="checkbox"/> Tracer wire continuity	Leak repair <input type="checkbox"/> Permanent <input type="checkbox"/> Temporary
	<input type="checkbox"/> NDI of welds <input type="checkbox"/> Other	

NON-MOBILE COMPLETION USERS ONLY

	Length (m)	Size (mm)	Material				
Extended past safe meter location			<input type="checkbox"/> PE <input type="checkbox"/> ST				
Abandoned pipe			<input type="checkbox"/> PE <input type="checkbox"/> ST				
Unit No. or address	FortisBC Meter No.	Manufacturer's No.	Dials	Reading	Del. Press	Reg tag	
<input checked="" type="checkbox"/> Install	<b>490</b>	<b>RCT1396459</b>	<b>20061459</b>	<b>4</b>	<b>∅</b>	<b>14</b>	<b>EF 12420</b>
<input type="checkbox"/> Remove							
<input type="checkbox"/> Reset							
<input type="checkbox"/> Install							
<input type="checkbox"/> Remove							
<input type="checkbox"/> Reset							

ID number **4060** Completion date (Yr/Mth/Day) **16/08/08**  
 b. Miller





ATTENTION: DO NOT RELY ON THIS INFORMATION ALONE. You must manually dig to locate gas lines before using excavation machinery. All locations are shown approximate only & gas lines built after the date below are not in this information package. BC Gas will not accept responsibility for errors or omissions. Depth of gas line are not available due to possible change of grade.

SCANNED

NOV 1 7 2013



As built correction

Requester information

Name Linda Tosin	Telephone number 604-576-7065	Date (m/m/yy) 2013/11/12
---------------------	----------------------------------	-----------------------------

Contractor information

Address A & B - 1198 Pacey St RD	Community Comox
Plate map number	Premise number 914518 and 914519
Meter number 637711 and 635058	

Please use this section for corrections only to existing on-line facility information

- Service line information
- Mains location (length & offsets)
- Mains information (fittings, valves & other similar information)
- Boundary information (property lines, easements, Right of Way, etc.)
- Please confirm service material
- Please confirm service size (if available)

Location Records Department  
Central Mapping Office (CMO)

**SIA COMPLETE**  
NOV 13 2013  
LT

Site plan

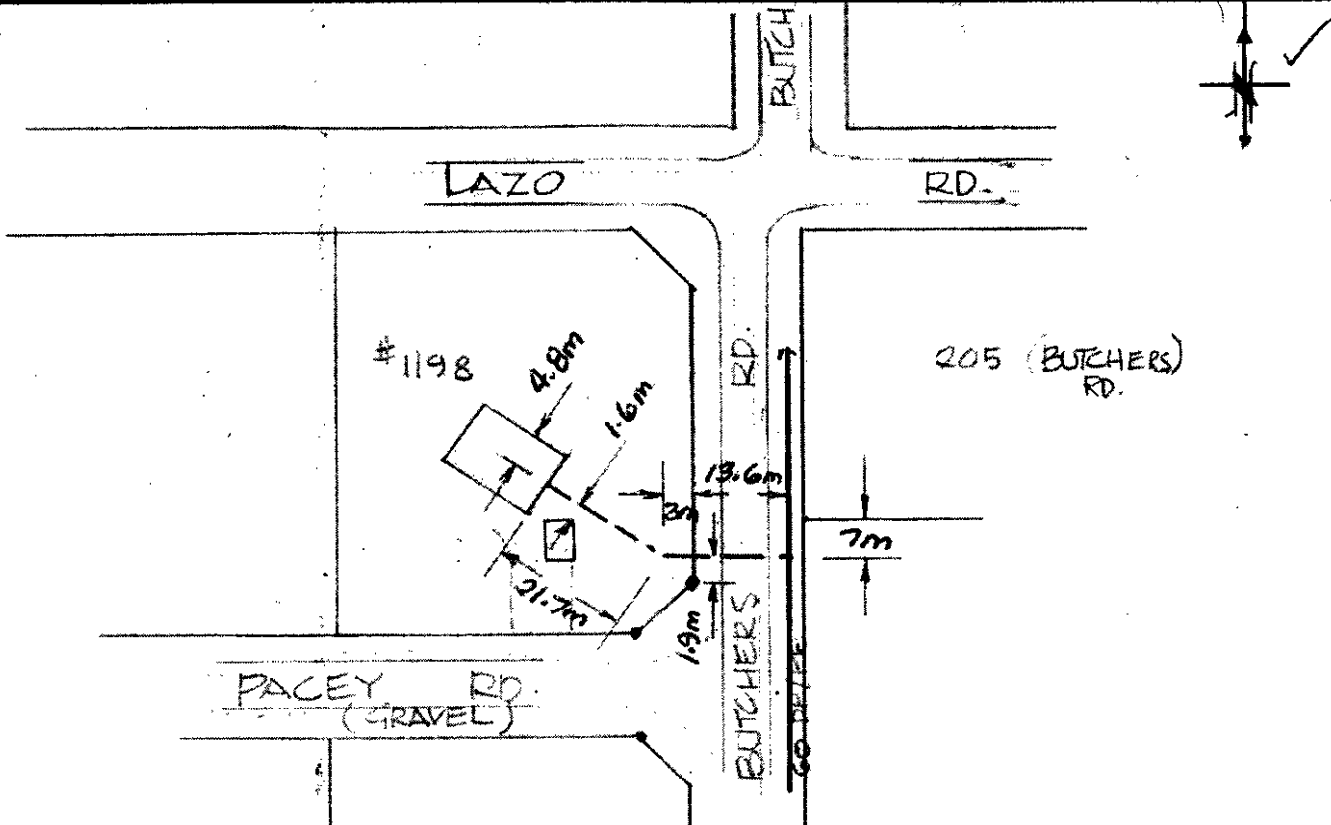

SAP order number n/a	Date (m/m/yy) 2013/11/13
-------------------------	-----------------------------

Drawn by *Chris Stoyles*

Comments (25 May 2000) *Original sketch is correctly drawn, just shown on the wrong lot, making some measurements wrong.*

Attachments - (please list (plans, etc. If more room needed))

ATTENTION: DO NOT RELY ON THIS INFORMATION ALONE. You must manually dig to locate gas lines before using excavation machinery. All locations are shown approximate only & gas lines built after the date below are not in this information package. BC Gas will not accept responsibility for errors or omissions. Depth of gas line are not available due to possible change of grade.

T-DOC



Job number  
**30853393**

For office use only:  
Premise number: **10052072001 - New**

Job address  
**LOT 2 BRENT RD.**

**(WALTER RD.)**

**COMOX**

Sketch: (measurement in metric)

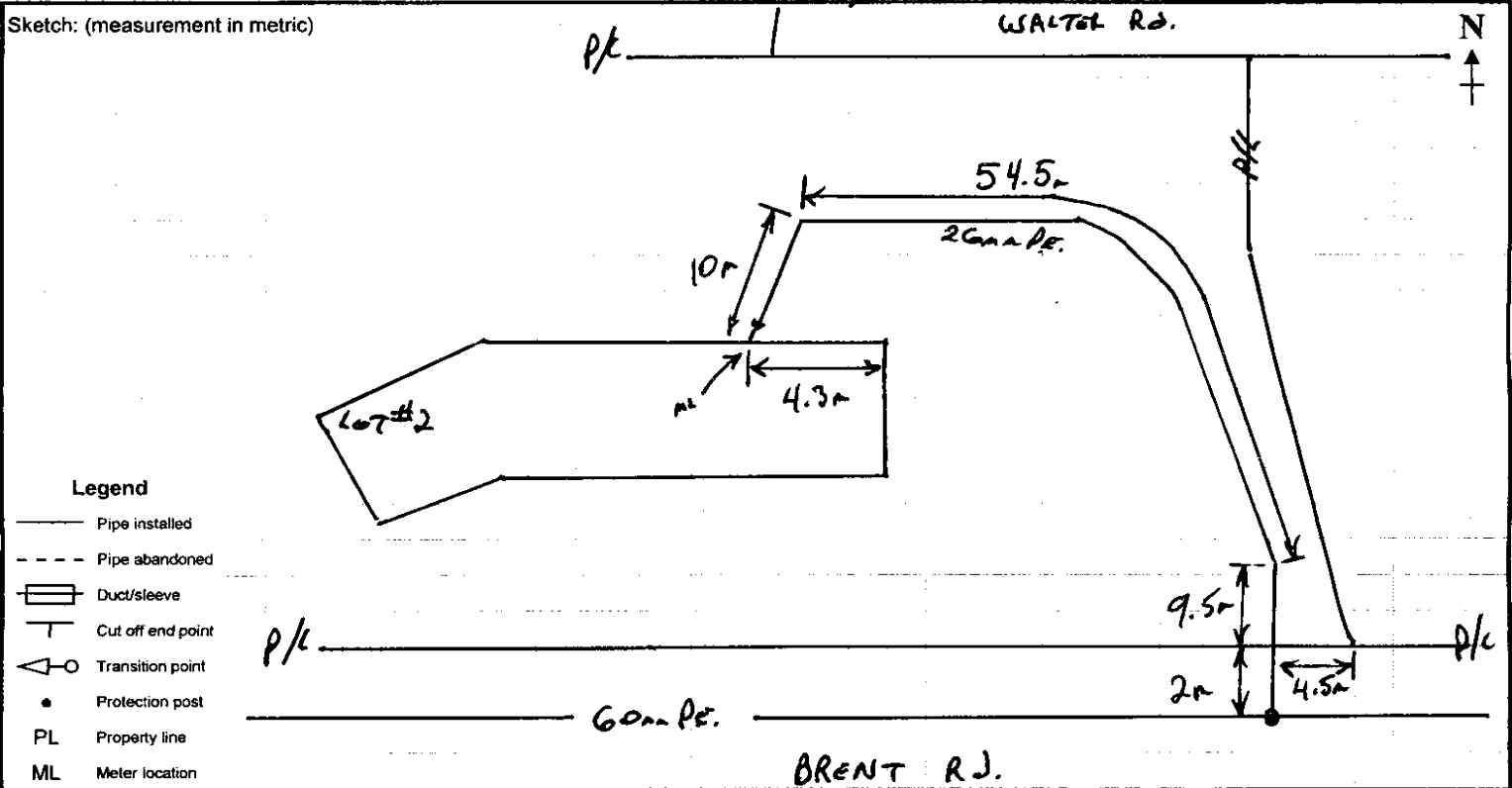

Description of work/additional comments:

**76mm OF 26mm P.E. SERVICE INSTALLED.**

Customer trench _____ length (m)	Tie in method <b>60K20mm P.T.T.</b>	Valve details:
Customer sleeve _____ length (m)	Depth of main (m) <b>1.3</b>	New Installs (mandatory) or Existing (if known)
Protection posts _____ quantity	Tap size (mm) <b>19</b>	<input type="checkbox"/> Service valve <input type="checkbox"/> Main valve
Winter charges apply? <input type="checkbox"/> Yes <input checked="" type="checkbox"/> No	Pressure test	Manufacturer _____
Snow shed <input type="checkbox"/> Yes <input checked="" type="checkbox"/> No	<input checked="" type="checkbox"/> Air      Pressure (kPa) <b>800</b> Duration <b>20min</b>	Model _____
<input type="checkbox"/> Dresser	<input type="checkbox"/> Nitrogen	Serial _____
<input type="checkbox"/> Mag anode installed	<input type="checkbox"/> Hydrostatic	Valve ID _____
<input type="checkbox"/> Insert thru old pipe	<input checked="" type="checkbox"/> Soap test	Leak category <input type="checkbox"/> 1 <input type="checkbox"/> 2
<input type="checkbox"/> Boring tool used	Inspections:	<input type="checkbox"/> Bottle/bag sample taken
<input type="checkbox"/> Stub marker ball	<input type="checkbox"/> Radiography (X-ray) <input checked="" type="checkbox"/> Tracer wire continuity	Leak repair <input type="checkbox"/> Permanent <input type="checkbox"/> Temporary
	<input type="checkbox"/> NDI of welds <input type="checkbox"/> Other	

NON-MOBILE COMPLETION USERS ONLY

	Length (m)	Size (mm)	Material				
Extended past safe meter location	(m)	(mm)	<input type="checkbox"/> PE	<input type="checkbox"/> ST			
Abandoned pipe	(m)	(mm)	<input type="checkbox"/> PE	<input type="checkbox"/> ST			
Unit No. or address	FortisBC Meter No.	Manufacturer's No.	Dials	Reading	Del. Press	Reg tag	
<input checked="" type="checkbox"/> Install	<b>LOT 2</b>	<b>SFT1297120</b>	<b>75816624</b>	<b>4</b>	<b>φ</b>	<b>14</b>	<b>EF10510</b>
<input type="checkbox"/> Remove							
<input type="checkbox"/> Reset							
<input type="checkbox"/> Install							
<input type="checkbox"/> Remove							
<input type="checkbox"/> Reset							

ID number

**4060**

**B. Miller**

Completion date (Yr/Mth/Day)

**16/08/18**





Power smart

### Underground Locates

BC 1 Call: 1-800-474-6886

BC Hydro: 1-866-960-3740

BC Hydro Fax: 1-866-844-3498

BC Hydro email: [bchlocates@bchydro.com](mailto:bchlocates@bchydro.com)

### Location of B.C. Hydro's Distribution Underground Electrical System

The attached drawing shows the location of our underground electrical system.

The underground system can be at a depth of 1 to 5 feet, depending on terrain, and/or changes to streets, boulevards and private properties since the original installation.

- Attached are the available drawings showing BC Hydro underground distribution facilities in the area requested. No additional accuracy should be assumed by using electronic remote locating devices.
- In accordance with WCB regulations, the contractor remains responsible for locating the facilities in the field before starting to excavate or drill.

**CAUTION ! Energized Cable  
OBEY THESE RULES !**

- First locate the underground facilities (a qualified locate contractor is recommended).
- Controlled excavation may be used to remove the excess overburden.
- Hand digging must then be used to expose facilities and prove exact location.
- Once exposed, mechanical digging may be used up to 50 cm from the facilities.
- Within 50 cm only hand digging is permitted.
- If a duct is exposed – the duct should be supported and protected to avoid any sagging or damage. The duct shall be re-covered with 150 MM of sand/aggregate below and 300 MM of sand/aggregate above and beside the duct. Warning tape shall be re-established 400 – 600 MM above the duct in the native soil. The drawing on page 2 shows typical depths.
- **Do not excavate within one metre of a BC Hydro device (such as switchgear, transformers, pole, and others) as additional hazards (such as electrical limits-of-approach and device stability) may exist.**

### DISCLAIMER

#### PLEASE NOTE:

***BC Hydro does not guarantee the location of our underground installation as shown on our drawings. Exact location of our underground plant must be proven by hand digging prior to excavating in proximity.***







A locate contractor is recommended for all construction activity with one (1.0) meter from B.C. Hydro facilities.

### PLEASE DIG CAREFULLY AND SAFELY!

If through some unforeseen circumstances the ducts are damaged **stop** work immediately and call our office at 1-888-769-3766.

Please note: Our legend is dynamic and only displays underground electrical if it exists in the provided schematic.

The following attributes are above ground assets and are not included in the legend.

	Service Location - Existing Location
	Pole - Existing Joint Use Location
	Transmission - Structure Location
	Transmission - Pole Location
	Transmission - Clamp Location
	Transmission - Overhead Line

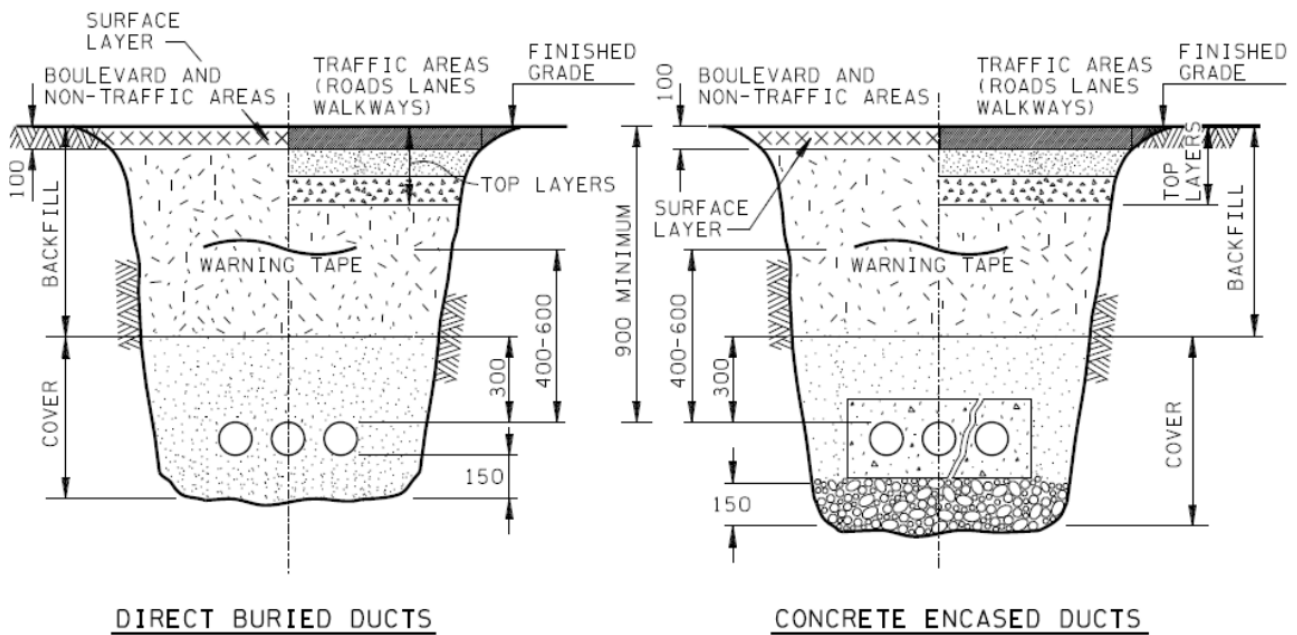

Ticket No: 2017123509

Name: DENNIS WU  
Company: OPUS INTERNATIONAL CONSULTANTS

2017-03-28

Street No. From:

Phone No.: 6049904800

Scale: 1:7501

Street No. To:

Street: \*\*\* SEE AFDD'L DIG II FAX No.:

City: COMOX VALLEY DISTRICT Email: dennis.wu@opus.co

Paper Sized for :  
11" x 17"

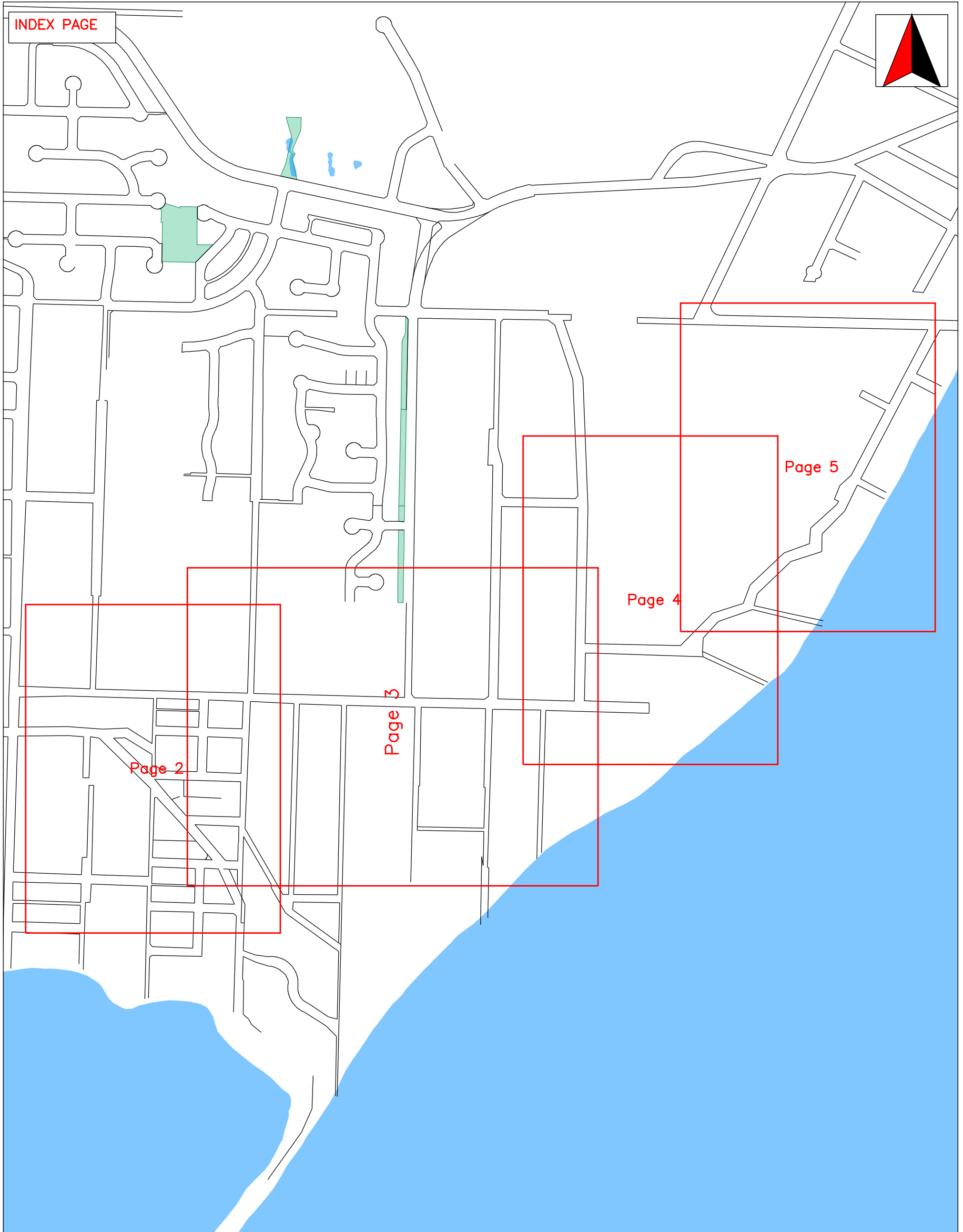

**THIS PRINT IS PROVIDED FOR GENERAL INFORMATION ONLY**

BC Hydro does not accept any responsibility for errors or omissions. The information provided is the most accurate information we have available. Beware that underground electrical systems may exist that have not been record "AS CONSTRUCTED" yet.

The onus is on the operator to hand dig to locate the actual underground utility before any mechanized digging proceeds.



Ticket No: 2017123509

Name: DENNIS WU  
Company: OPUS INTERNATIONAL CONSULTANTS

Paper Sized for :  
11" x 17"

2017-03-28

Scale: 1:2000

Street No. From:  
Street No. To:  
Street: \*\*\* SEE AFDD'L DIG II FAX No.:  
City: COMOX VALLEY DISTRICT Email: dennis.wu@opus.co

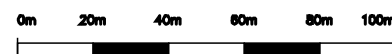

**DETERMINING THE LOCATION OF UNDERGROUND OR EMBEDDED CONDUIT AND CONDUCTOR ON PRIVATE PROPERTY IS THE SOLE RESPONSIBILITY OF THE PROPERTY OWNER**

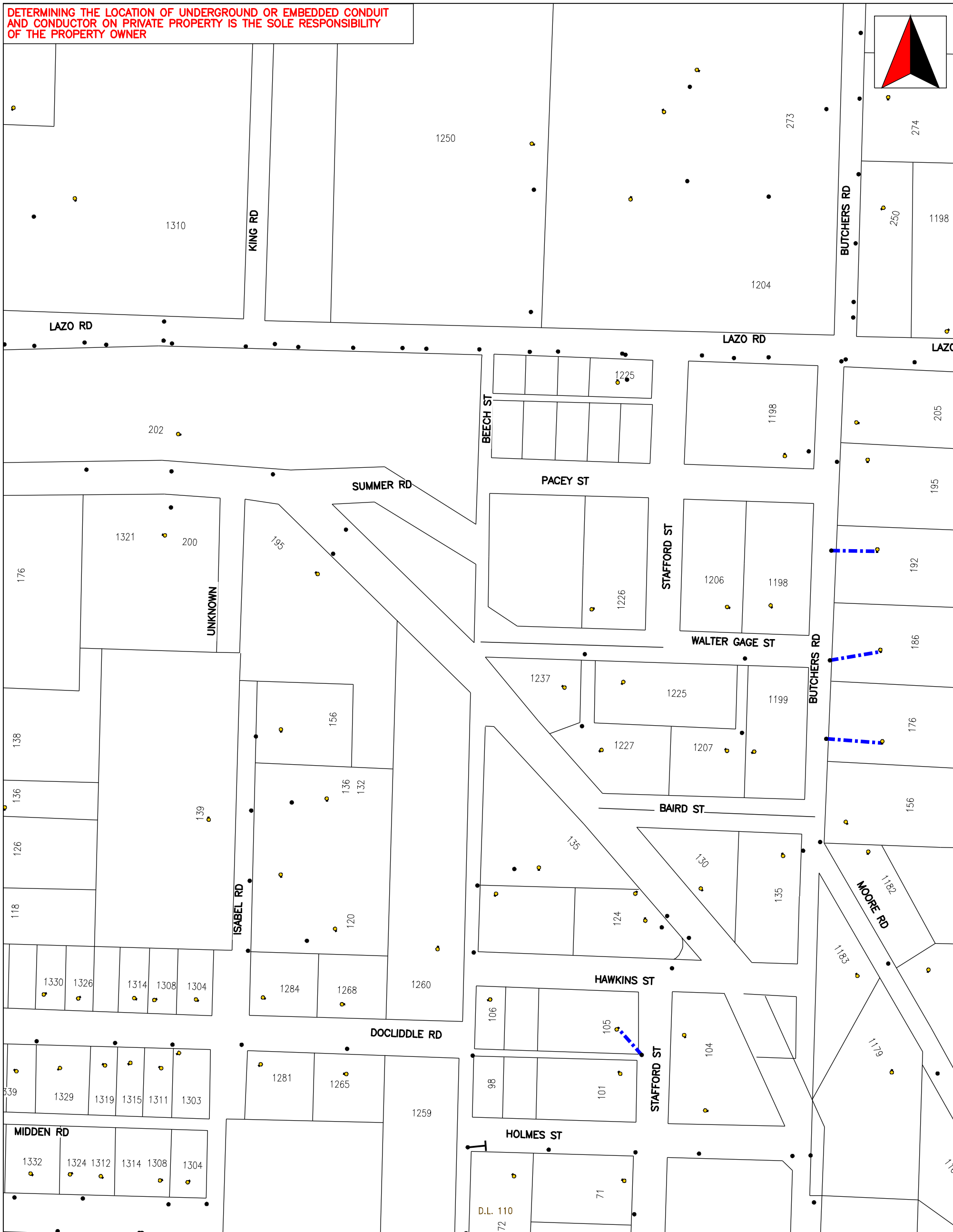
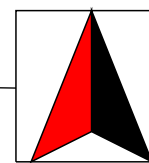

**THIS PRINT IS PROVIDED FOR GENERAL INFORMATION ONLY**

BC Hydro does not accept any responsibility for errors or omissions. The information provided is the most accurate information we have available. Beware that underground electrical systems may exist that have not been record "AS CONSTRUCTED" yet.

The onus is on the operator to hand dig to locate the actual underground utility before any mechanized digging proceeds.

**Legend**

distribution underground [Gis]  
- - - U/G Secondary

Ticket No: 2017123509

Name: DENNIS WU  
Company: OPUS INTERNATIONAL CONSULTANTS

Street No. From:

Phone No.: 6049904800

Street No. To:

Street: \*\*\* SEE AFDD'L DIG II FAX No.:

City: COMOX VALLEY DISTRICT Email: dennis.wu@opus.co

Paper Sized for :  
11" x 17"

2017-03-28

Scale: 1:2500



**DETERMINING THE LOCATION OF UNDERGROUND OR EMBEDDED CONDUIT AND CONDUCTOR ON PRIVATE PROPERTY IS THE SOLE RESPONSIBILITY OF THE PROPERTY OWNER**



**THIS PRINT IS PROVIDED FOR GENERAL INFORMATION ONLY**  
BC Hydro does not accept any responsibility for errors or omissions. The information provided is the most accurate information we have available. Beware that underground electrical systems may exist that have not been record "AS CONSTRUCTED" yet.  
The onus is on the operator to hand dig to locate the actual underground utility before any mechanized digging proceeds.

**Legend**

	U/G Primary
	U/G Secondary
	U/G Secondary
	U/G Transformer

Ticket No: 2017123509

Name: DENNIS WU  
Company: OPUS INTERNATIONAL CONSULTANTS

Paper Sized for :  
11" x 17"

2017-03-28

Scale: 1:2000

Street No. From:  
Street No. To:  
Street: \*\*\* SEE AFDD'L DIG II FAX No.:  
City: COMOX VALLEY DISTRICT Email: dennis.wu@opus.co

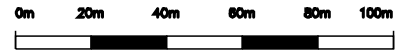

**DETERMINING THE LOCATION OF UNDERGROUND OR EMBEDDED CONDUIT AND CONDUCTOR ON PRIVATE PROPERTY IS THE SOLE RESPONSIBILITY OF THE PROPERTY OWNER**

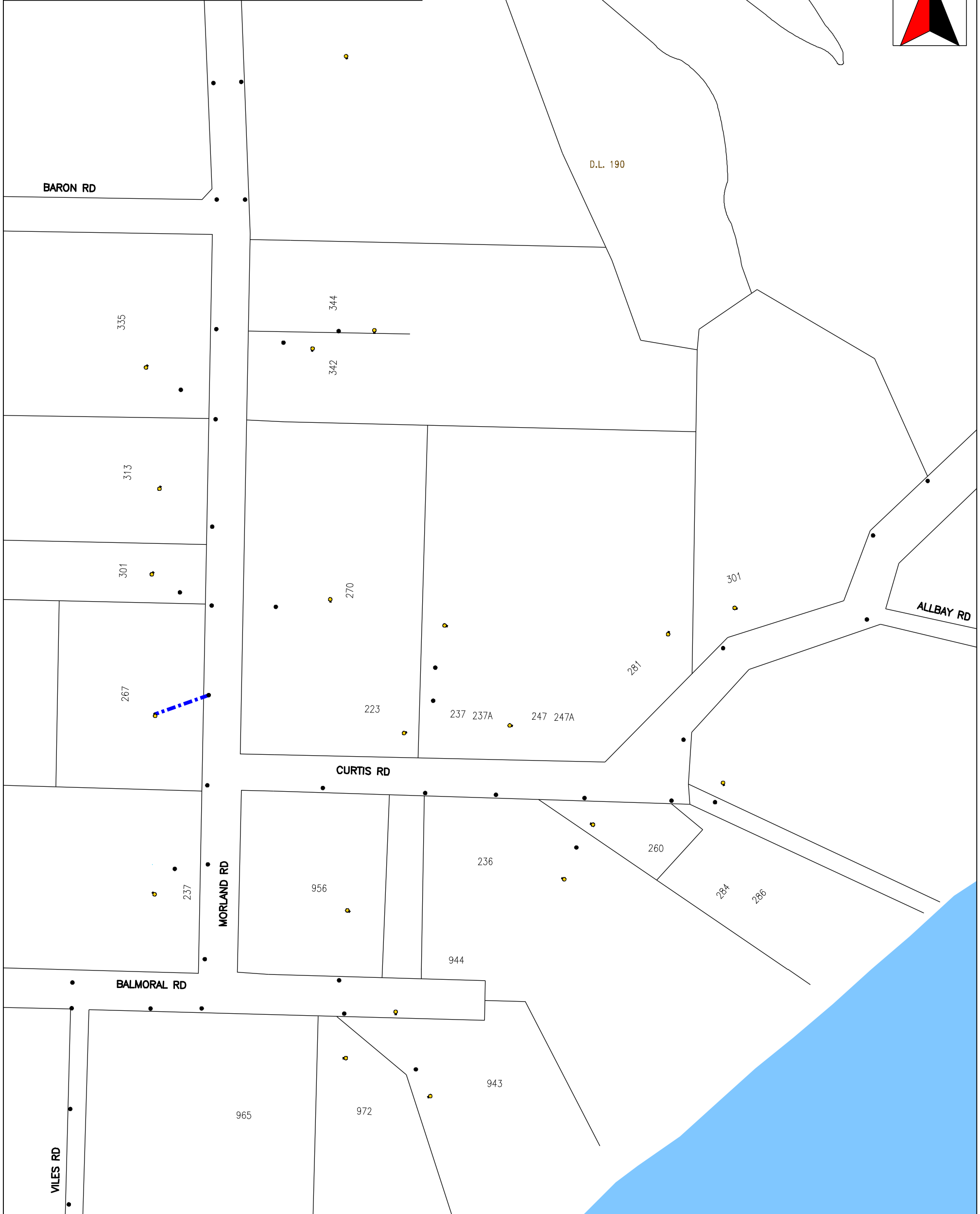
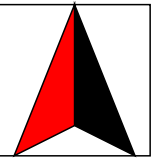



**THIS PRINT IS PROVIDED FOR GENERAL INFORMATION ONLY**

BC Hydro does not accept any responsibility for errors or omissions. The information provided is the most accurate information we have available. Beware that underground electrical systems may exist that have not been record "AS CONSTRUCTED" yet.

The onus is on the operator to hand dig to locate the actual underground utility before any mechanized digging proceeds.

**Legend**

**distribution underground [Gis]**

-  U/G Primary
-  U/G Secondary

Ticket No: 2017123509

Name: DENNIS WU  
Company: OPUS INTERNATIONAL CONSULTANTS

2017-03-28

Street No. From:

Phone No.: 6049904800

Scale: 1:2000

Street No. To:

Street: \*\*\* SEE AFDD'L DIG II FAX No.:

City: COMOX VALLEY DISTRICT Email: dennis.wu@opus.co

Paper Sized for :  
11" x 17"

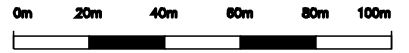

**DETERMINING THE LOCATION OF UNDERGROUND OR EMBEDDED CONDUIT AND CONDUCTOR ON PRIVATE PROPERTY IS THE SOLE RESPONSIBILITY OF THE PROPERTY OWNER**

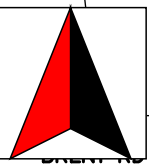
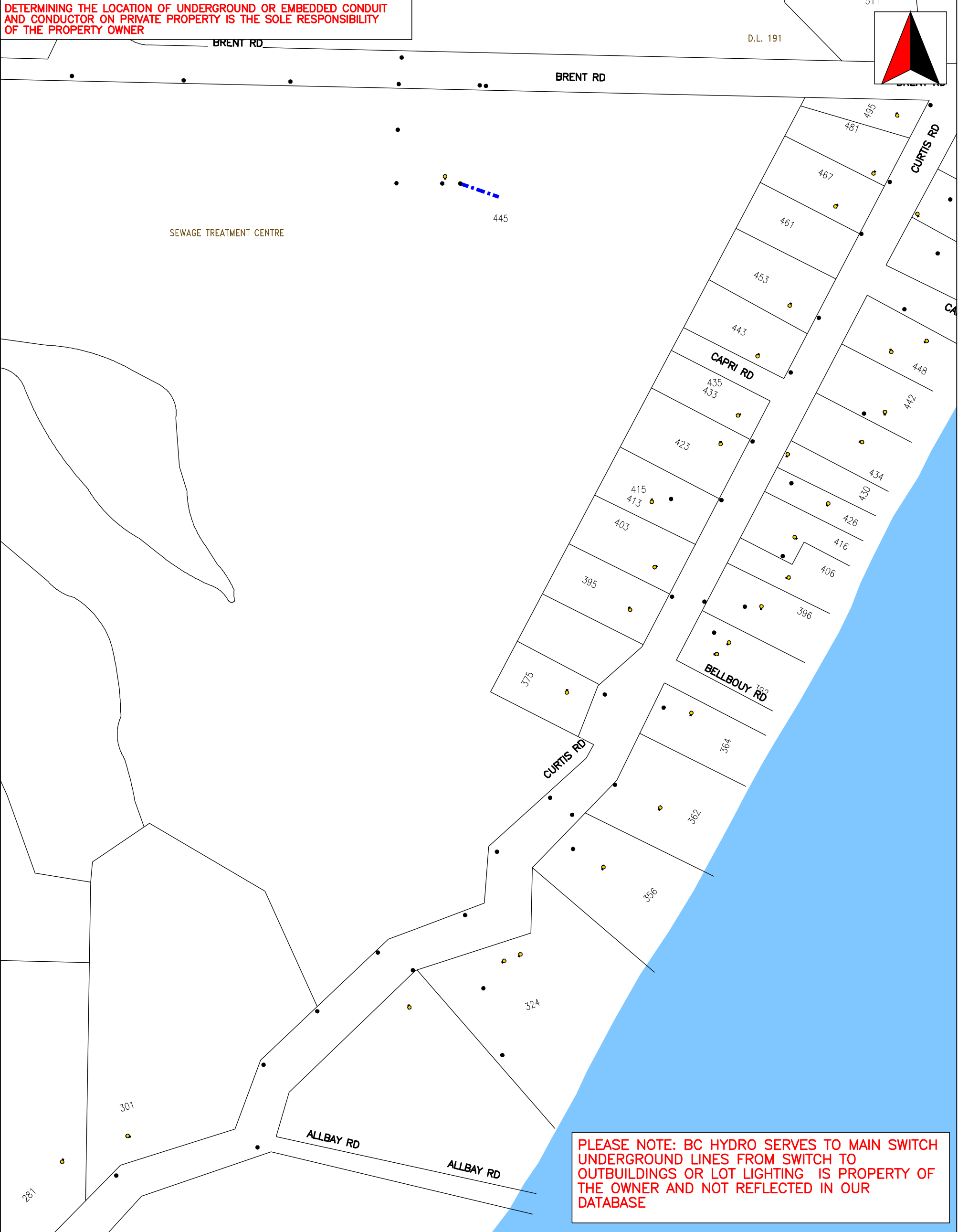



**PLEASE NOTE: BC HYDRO SERVES TO MAIN SWITCH UNDERGROUND LINES FROM SWITCH TO OUTBUILDINGS OR LOT LIGHTING IS PROPERTY OF THE OWNER AND NOT REFLECTED IN OUR DATABASE**

**THIS PRINT IS PROVIDED FOR GENERAL INFORMATION ONLY**  
BC Hydro does not accept any responsibility for errors or omissions. The information provided is the most accurate information we have available. Beware that underground electrical systems may exist that have not been record "AS CONSTRUCTED" yet.  
  
The onus is on the operator to hand dig to locate the actual underground utility before any mechanized digging proceeds.

**Legend**

**distribution underground [Gis]**

-  U/G Primary
-  U/G Secondary

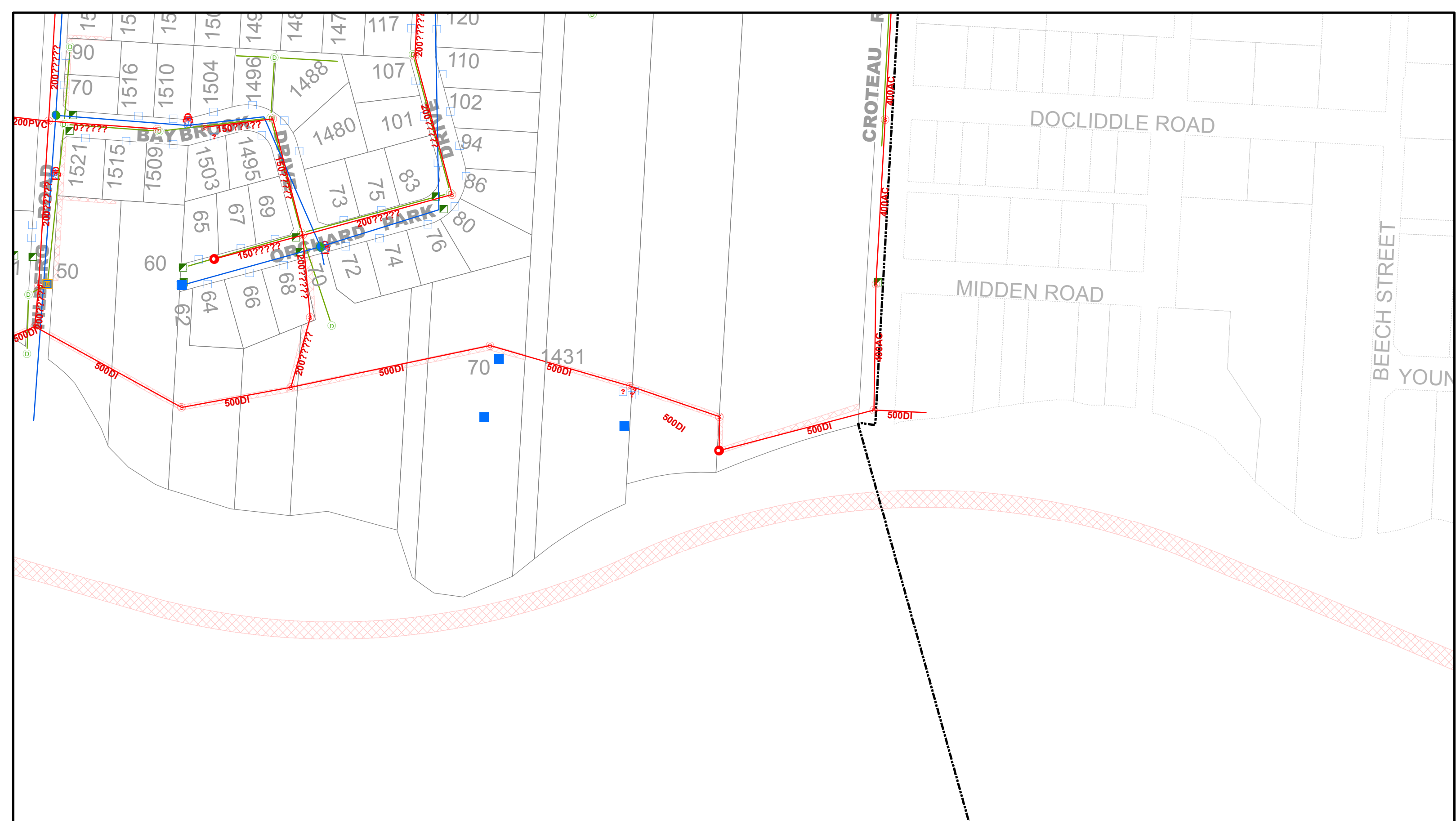

# Engineering Layers

Map 3

- |                    |                         |                         |                           |                       |
|--------------------|-------------------------|-------------------------|---------------------------|-----------------------|
| Sanitary Mains     | Pressure Release Valves | Water Meter (to verify) | Storm Mains               | Town Boundary         |
| Sani Catch Basin   | Air Release Valves      | METERVAULT              | Storm Catch Basin         | Parcels               |
| Sani Cleanout      | Water Isolation Valves  | Water meter             | Storm Cleanout            | Outside Town Boundary |
| Sani Lift Station  | Water Valve - Closed    | WTS WM                  | Storm Manhole             | SRW_poly              |
| Sani Manhole       | Water Valve - Open      | Water Mains             | Storm Outfall             |                       |
| Sani Pump Station  | Watervalue              | WaterLeads              | Storm Service Cap         |                       |
| Sani Service Valve | Water Blow Offs         |                         | Storm Private Catch Basin |                       |

0 50 100 150 m

1:2,000

NAD83 UTM 10  
Map Updated: January 4, 2017  
Map By: Mapping Dept.



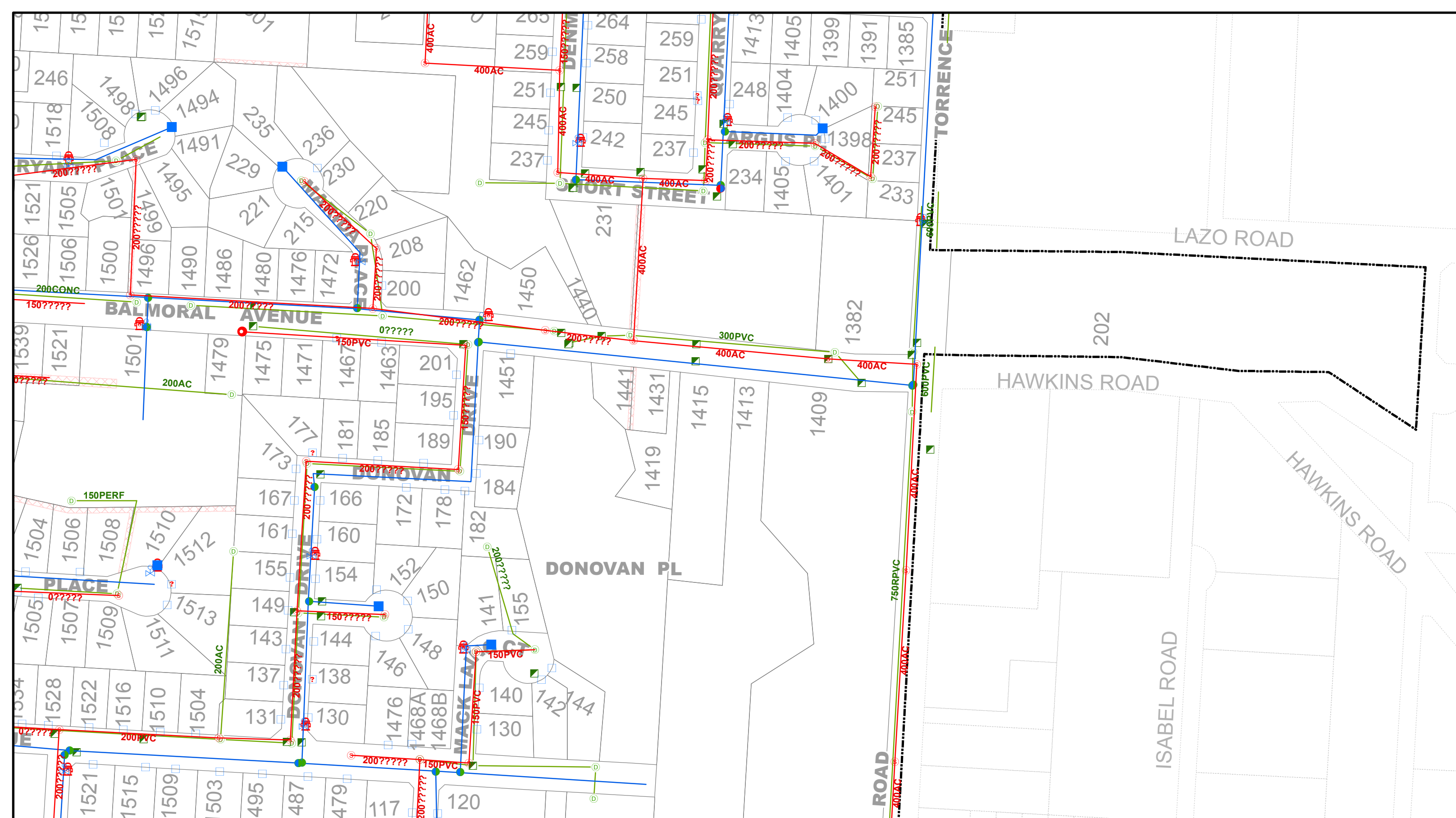

# Engineering Layers

Map 7

- |                    |                         |                         |                           |                       |
|--------------------|-------------------------|-------------------------|---------------------------|-----------------------|
| Sanitary Mains     | Pressure Release Valves | Water Meter (to verify) | Storm Mains               | Town Boundary         |
| Sani Catch Basin   | Air Release Valves      | METERVAULT              | Storm Catch Basin         | Parcels               |
| Sani Cleanout      | Water Isolation Valves  | Water meter             | Storm Cleanout            | Outside Town Boundary |
| Sani Lift Station  | Water Valve - Closed    | WTS WM                  | Storm Manhole             | SRW_poly              |
| Sani Manhole       | Water Valve - Open      | Water Mains             | Storm Outfall             |                       |
| Sani Pump Station  | Watervalue              | WaterLeads              | Storm Service Cap         |                       |
| Sani Service Valve | Water Blow Offs         |                         | Storm Private Catch Basin |                       |

0 50 100 150 m

1:2,000

NAD83 UTM 10  
Map Updated: January 4, 2017  
Map By: Mapping Dept.



# Engineering Layers

Map 8

- |                    |                         |                         |                           |                       |
|--------------------|-------------------------|-------------------------|---------------------------|-----------------------|
| Sanitary Mains     | Pressure Release Valves | Water Meter (to verify) | Storm Mains               | Town Boundary         |
| Sani Catch Basin   | Air Release Valves      | METERVAULT              | Storm Catch Basin         | Parcels               |
| Sani Cleanout      | Water Isolation Valves  | Water meter             | Storm Cleanout            | Outside Town Boundary |
| Sani Lift Station  | Water Valve - Closed    | WTS WM                  | Storm Manhole             | SRW_poly              |
| Sani Manhole       | Water Valve - Open      | Water Mains             | Storm Outfall             |                       |
| Sani Pump Station  | Watervalue              | WaterLeads              | Storm Service Cap         |                       |
| Sani Service Valve | Water Blow Offs         |                         | Storm Private Catch Basin |                       |

0 50 100 150 m

1:2,000

NAD83 UTM 10  
Map Updated: January 4, 2017  
Map By: Mapping Dept.





# Engineering Layers

Map 13

- |                    |                         |                         |                           |                       |
|--------------------|-------------------------|-------------------------|---------------------------|-----------------------|
| Sanitary Mains     | Pressure Release Valves | Water Meter (to verify) | Storm Mains               | Town Boundary         |
| Sani Catch Basin   | Air Release Valves      | METERVAULT              | Storm Catch Basin         | Parcels               |
| Sani Cleanout      | Water Isolation Valves  | Water meter             | Storm Cleanout            | Outside Town Boundary |
| Sani Lift Station  | Water Valve - Closed    | WTS WM                  | Storm Manhole             | SRW_poly              |
| Sani Manhole       | Water Valve - Open      | Water Mains             | Storm Outfall             |                       |
| Sani Pump Station  | Watervalue              | WaterLeads              | Storm Service Cap         |                       |
| Sani Service Valve | Water Blow Offs         |                         | Storm Private Catch Basin |                       |

0 50 100 150 m

1:2,000

NAD83 UTM 10  
 Map Updated: January 4, 2017  
 Map By: Mapping Dept.

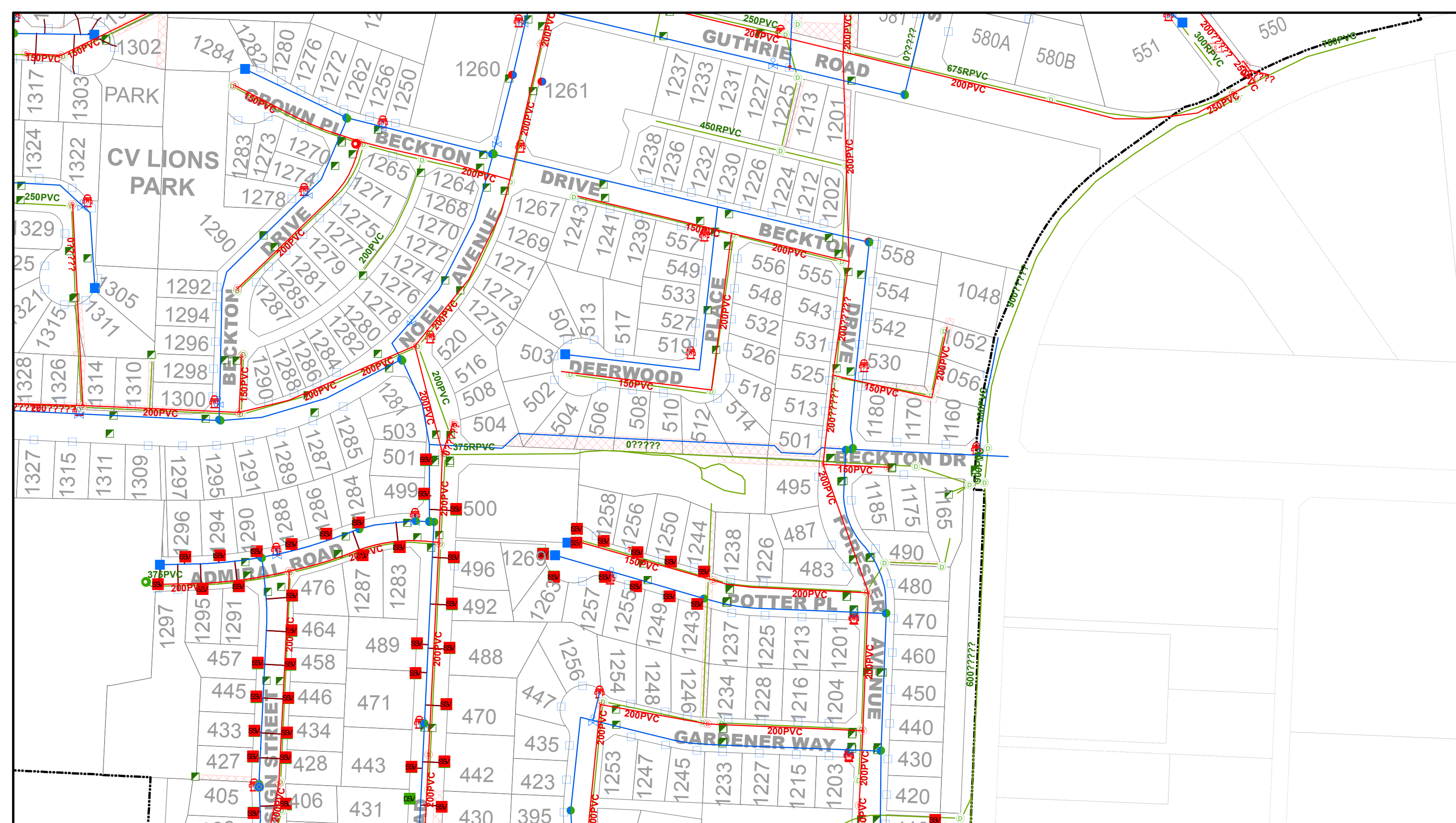

# Engineering Layers

Map 19

- |                      |                           |                           |                             |                         |
|----------------------|---------------------------|---------------------------|-----------------------------|-------------------------|
| — Sanitary Mains     | ★ Pressure Release Valves | ⊠ Water Meter (to verify) | — Storm Mains               | ⬜ Town Boundary         |
| ⊠ Sani Catch Basin   | ⊙ Air Release Valves      | ⊠ METERVAULT              | ⊠ Storm Catch Basin         | ⬜ Parcels               |
| ⊙ Sani Cleanout      | ⊗ Water Isolation Valves  | ⊠ Water meter             | ⊙ Storm Cleanout            | ⬜ Outside Town Boundary |
| ⊠ Sani Lift Station  | ⊙ Water Valve - Closed    | ⊠ WTS WM                  | ⊙ Storm Manhole             | ⊠ SRW_poly              |
| ⊙ Sani Manhole       | ⊙ Water Valve - Open      | — Water Mains             | ⊠ Storm Outfall             |                         |
| ⊠ Sani Pump Station  | ⊠ Watervalue              | — WaterLeads              | ⊠ Storm Service Cap         |                         |
| ⊠ Sani Service Valve | ⊠ Water Blow Offs         |                           | ⊠ Storm Private Catch Basin |                         |

0 50 100 150 m

1:2,000

NAD83 UTM 10  
Map Updated: January 4, 2017  
Map By: Mapping Dept.

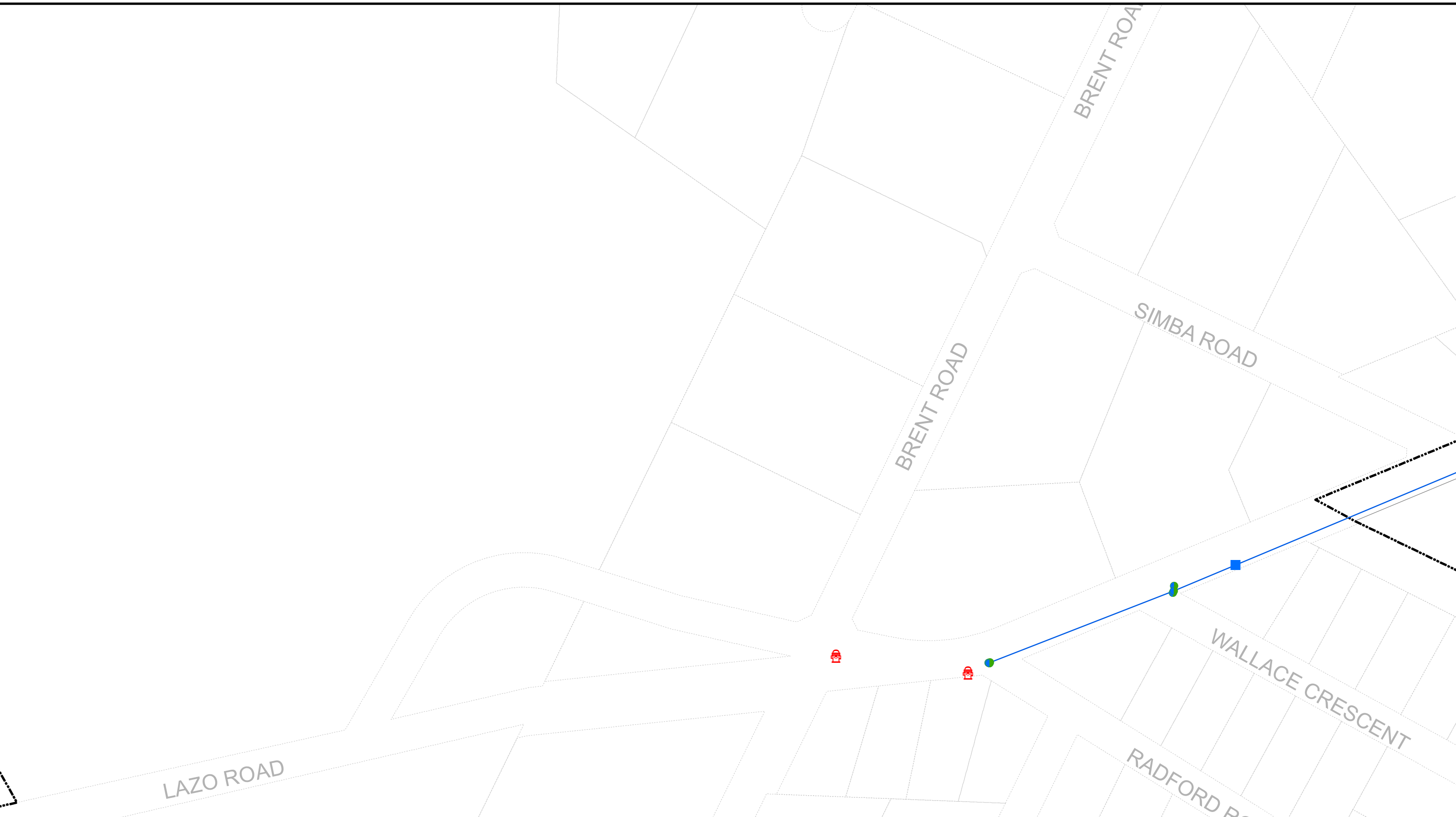

# Engineering Layers

Map 26

- |                    |                         |                         |                           |                       |
|--------------------|-------------------------|-------------------------|---------------------------|-----------------------|
| Sanitary Mains     | Pressure Release Valves | Water Meter (to verify) | Storm Mains               | Town Boundary         |
| Sani Catch Basin   | Air Release Valves      | METERVAULT              | Storm Catch Basin         | Parcels               |
| Sani Cleanout      | Water Isolation Valves  | Water meter             | Storm Cleanout            | Outside Town Boundary |
| Sani Lift Station  | Water Valve - Closed    | WTS WM                  | Storm Manhole             | SRW_poly              |
| Sani Manhole       | Water Valve - Open      | Water Mains             | Storm Outfall             |                       |
| Sani Pump Station  | Watervalue              | WaterLeads              | Storm Service Cap         |                       |
| Sani Service Valve | Water Blow Offs         |                         | Storm Private Catch Basin |                       |

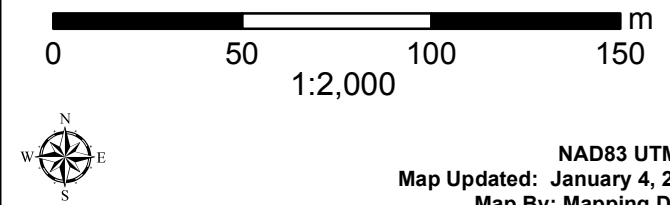

NAD83 UTM 10  
 Map Updated: January 4, 2017  
 Map By: Mapping Dept.

## **APPENDIX H – DETAILED COST ESTIMATE**



Discipline	Location	Description	QTY	UOM	Unit Cost	Labour Factor	Mark-up Factor	Purchase/Labor	Notes
Civil-Align	Alignment	Foreshore Tie-in at the bottom of Beech St.	1.0	L.S.	\$ 1,769,683	1.15	1.15	\$2,340,406.1	
Civil-Align	Alignment	Pressurized 70" MH, 6' rise, lid, hatch	1.0	ea	\$ 5,500	1.15	1.15	\$7,273.8	freight allowed
Civil-Align	Alignment	Fxf spoils to FM		LS	\$ 52,000	1.15	1.15	\$68,770.0	
Civil-Align	Alignment	Flowmeter 54"OD MH	1.0	ea	\$ 66,000	1.15	1.15	\$87,285.0	freight allowed
Civil-Align	Alignment	Isolation Gate Valve 54"OD	2.0	ea	\$ 115,000	1.15	1.15	\$304,175.0	freight allowed
Civil-Align	Alignment	54"OD HDPE DR21 (80PSI)	2,500.0	m	\$ 22	1.15	1.15	\$72,676.8	48"OD DR21(80 psi) - \$286/50'
Civil-Align	Alignment	HDPE Pipe Joints	166.7	ea	\$ 1,400	1.15	1.15	\$308,583.3	fusing and labour from Corix
Civil-Align	Alignment	HDPE Pipe freight		LS	\$ 90,000	1.00	1.15	\$90,000.0	From Corix
Civil-Align	Alignment	65mm asphalt pavement	12,500.0	m <sup>2</sup>	\$ 45	1.0	1.15	\$646,875.0	RSMeans 32 12 16.13 0130
Civil-Align	Alignment	Trenching backfill - coarse aggregate	5,550.0	m <sup>3</sup>	\$ 17	1.50	1.15	\$162,753.8	Emerald
Civil-Align	Alignment	Trenching backfill - utility bedding	31,726.0	m <sup>3</sup>	\$ 52	1.00	1.00	\$1,661,047.1	RSMeans 31 23 23.16
Civil-Align	Alignment	Backfill material hauling	37,276.0	m <sup>3</sup>	\$ 7	1.00	1.00	\$268,348.2	Average 2mile hauling RSMEANS 31.23.23.20
Civil-Align	Alignment	Trenching Excavation	11,550.0	m <sup>3</sup>	\$ 5	1.20	1.00	\$63,494.8	Average common earth excavation RSMEANS 31.23
Civil-Align	Alignment	8" DI Supply watermain	500.0	m	\$ 90	1.15	1.15	\$59,512.5	From Corix
Civil-Align	Alignment	65mm asphalt pavement	2,500.0	m <sup>2</sup>	\$ 45	1.0	1.15	\$129,375.0	RSMeans 32 12 16.13 0130
Civil-Align	Alignment	Supply watermain Trenching backfill - coarse aggregate	210.0	m <sup>3</sup>	\$ 17	1.50	1.15	\$6,158.3	Emerald
Civil-Align	Alignment	Supply watermain Trenching backfill - utility bedding	134.0	m <sup>3</sup>	\$ 52	1.00	1.00	\$7,015.7	RSMeans 31 23 23.16
Civil-Align	Alignment	Supply watermain Trenching Excavation	360.0	m <sup>3</sup>	\$ 5	1.20	1.00	\$1,979.1	Average common earth excavation RSMEANS 31.23
Civil-Align	Alignment	Curtis Road Fortis BC 60mm DP Gas line mitigation for construction	700.0	m					
Civil-Site	General	Site Clearing and Grubbing for linear work	22,400.0	m <sup>2</sup>	\$ 5	1.0	1.00	\$112,000.0	
Civil-Site	General	Staging and Laydown area	150.0	m <sup>2</sup>	\$ 50	1.0	1.00	\$7,500.0	From historical costs on other projects - equipment and labour combined.
Civil-Site	General	Tree Replacement	6.0	ea	\$ 800	1.2	1.00	\$5,760.0	From Emerald Tender
Civil-Site	General	Well replacement	4.0	ea	\$ 2,500	1.0	1.00	\$10,000.0	From Wet Suwet En
Civil-Site	General	65mm asphalt pavement - 5x17.6m driveway	88.0	m <sup>2</sup>	\$ 45	1.0	1.15	\$4,554	RSMeans 32 12 16.13 0130
Civil-Site	General	150mm crushed gravel base	52.4	m <sup>3</sup>	\$ 17	1.5	1.15	\$1,537	
Civil-Site	General	500mm subbase gravel	28.8	m <sup>3</sup>	\$ 35	1.5	1.15	\$1,739	
Civil-Site	General	PS Site Clearing and Grubbing	900.0	m <sup>2</sup>	\$ 5	1.0	1.00	\$4,500.0	RSMeans 31 11 10.10 0200, assume 30X30 for main site plus another 700m2 for staging and laydown.
Civil-Site	General	Stripping to 200mm average depth and Stockpile Top Soil	900.0	m <sup>2</sup>	\$ 30	1.0	1.00	\$27,000.0	RSMeans 31 14 13.23 1430
Civil-Site	General	Site Grading		L.S.		1.0	1.15	\$0.0	RSMeans31 22 13 0200
Civil-Site	General	Hauling dirt away from site	35.0	Truckload	\$ 120	1.0	1.00	\$4,200.0	RSMeans 31 23 23.20 0024
Civil-Site	General	Imported structural fill including hauling	100.0	m <sup>3</sup>	\$ 50	1.0	1.00	\$5,000.0	Undetermined without geotech
Civil-Site	General	Deep Excavation	5,000.0	m <sup>3</sup>	\$ 50	1.0	1.15	\$287,500.0	Undetermined without geotech
Civil-Site	General	Shallow Excavation	1,280.0	m <sup>3</sup>	\$ 35	1.0	1.15	\$51,520.0	Undetermined without geotech
Civil-Site	General	Shoring	432.0	m <sup>2</sup>	\$ 100	1.0	1.15	\$49,680.0	Undetermined without geotech
Civil-Site	General	Site Dewatering	60.0	d	\$ 1,000	1.0	1.00	\$60,000.0	Not considered currently due to absence of geotech
Process-Mechanical	Wet Well	SLG 1110	1.0	ea	\$ 35,000	1.15	1.15	\$46,287.5	Prorated from supplier pricing AVK valves
Instrumentation	Wet Well	LE/LIT 1000	1.0	ea					
Process-Mechanical	Wet Well	400mm TF-1	5.0	ea	\$ 1,500	1.15	1.15	\$9,918.8	Prorated from emerald
Process-Mechanical	Dry Well	400mm PV 1121,2,3,4	5.0	\$	\$ 5,500	1.15	1.15	\$36,368.8	<a href="https://www.usabluebook.com/c-1297-plug-valves.aspx">https://www.usabluebook.com/c-1297-plug-valves.aspx</a>
Process-Mechanical	Dry Well	CAV 1130,1140	2.0	ea	\$ 1,000	1.15	1.15	\$2,645.0	<a href="https://www.usabluebook.com/t-searchresults.aspx?kwd=CAV">https://www.usabluebook.com/t-searchresults.aspx?kwd=CAV</a>
Process-Mechanical	Dry Well	Sewage Pump P-110.1.,2.,3.,4	4.0	ea	\$ 160,000	1.15	1.15	\$846,400.0	
Process-Mechanical	Dry Well	CV 1111,2,3,4	4.0	ea	\$ 10,000	1.15	1.15	\$52,900.0	
Process-Mechanical	Dry Well	PV 120.1.,2.,3.,4	5.0	ea	\$ 5,500	1.15	1.15	\$36,368.8	<a href="https://www.usabluebook.com/c-1297-plug-valves.aspx">https://www.usabluebook.com/c-1297-plug-valves.aspx</a>
Process-Mechanical	Dry Well	1050 SCH 40 CS material	15.0	m	\$ 350,000	1.00	1.00	\$350,000.0	Includes fabrication and installation
Process-Mechanical	Dry Well	400 SCH 40 CS material	40.0	m		1.00	1.00	\$0.0	
Process-Mechanical	Dry Well	300 SCH 40 CS	5.0	m		1.00	1.00	\$0.0	include 4 Reducers 300x400
Instrumentation	Dry Well	PE/PIT 1150	1.0	ea	\$ 800	1.15	1.15	\$1,058.0	
Instrumentation	Dry Well	FE/FIT 1160	1.0	ea	\$ 2,600	1.15	1.15	\$3,438.5	<a href="https://www.instrumart.com/products/40544/rosemount-8750w-magnetic-flow-meter">https://www.instrumart.com/products/40544/rosemount-8750w-magnetic-flow-meter</a>
Process-Mechanical	Outdoor	Biofilter	1.0	ea	\$ 2,000	1.15	1.15	\$2,645.0	Estimated
Plumbing	Dry Well	Non-potable Water SS	1.0	L.S.	\$ 120,000	1.00	1.00	\$ 120,000	
Plumbing	Dry Well	Drain pipe PVC							
Plumbing	Odour Control	Drain pipe CPVC							
Plumbing	Odour Control	FD							
HVAC	Dry Well	FOA duct SS		L.S.	\$ 50,000	1.50	1.00	\$ 75,000	
HVAC	Odour Control	FOA BV 2100	1.0	ea					
Instrumentation	Odour Control	FOA FE/FIT 2130	1.0	ea					
HVAC	Odour Control	FOA EF 2150	1.0	ea					
HVAC	Odour Control	FOA Blast Gate	2.0	ea					
HVAC	Odour Control	FOA MD 2170	1.0	ea					
HVAC	Odour Control	FOA Mist Grease Filter ME 2190	1.0	ea					
HVAC	Odour Control	Odour Control System Hee-Duall Carbon Adsorption	1.0	ea	\$ 58,880	1.00	1.20	\$74,531.0	Include start-up and Operator Training
HVAC	Electrical	600 mm fan	1.0	ea	\$ 100,000	1.50	1.00	\$150,000.0	
HVAC	General	Louvers		L.S.					
HVAC	Electrical	10 tonne, 34KW AC Unit	1.0	ea					
HVAC	Odour Control	750mm fan	1.0	ea					
HVAC	Dry Well	750mm fan	1.0	ea					
HVAC	Dry Well 2nd floor	750mm fan	1.0	ea					
HVAC	Wet Well	1,000 mm fan	1.0	ea					
HVAC	Generator	600 mm fan	1.0	ea					





Architectural	Dry well	External South Wall - 19 mm GIS Plywood painted	46.2	m <sup>2</sup>	\$	29	1.00	1.15	\$	1,515.11	RSMeans 04 22 10.24.0200
Architectural	Wet Well	External East Wall - Water proof coating	100.3	m <sup>2</sup>							
Architectural	Dry well	External East Wall - Furring Strips Air Gap	46.2	m <sup>2</sup>	\$	3	1.00	1.15	\$	137.02	RSMeans 06 16 36.10 0800
Architectural	Dry well	External East Wall - 6mm Poly Vapour Barrier	96.9	m <sup>2</sup>	\$	3	1.00	1.15	\$	287.57	RSMeans 07 21 13.10.0440
Architectural	Dry well	External East Wall - 75 mm Rigid insulation	96.9	m <sup>2</sup>	\$	32	1.00	1.15	\$	3,553.96	RSMeans 06 16 36.10 0800
Architectural	Dry well	External East Wall - 19 mm GIS Plywood painted	96.9	m <sup>2</sup>	\$	29	1.00	1.15	\$	3,179.86	RSMeans 06 16 36.10 0800
Architectural	Wet Well	External West Wall - Water proof coating	100.3	m <sup>2</sup>							
Architectural	Dry well	External West Wall - Furring Strips Air Gap	96.9	m <sup>2</sup>	\$	3	1.00	1.15	\$	287.57	RSMeans 06 16 36.10 0800
Architectural	Dry well	External West Wall - 6mm Poly Vapour Barrier	96.9	m <sup>2</sup>	\$	3	1.00	1.15	\$	287.57	RSMeans 04 22 10.24.0200
Architectural	Dry well	External West Wall - 75 mm Rigid insulation	96.9	m <sup>2</sup>	\$	32	1.00	1.15	\$	3,553.96	RSMeans 07 21 13.10.0440
Architectural	Dry well	External West Wall - 19 mm GIS Plywood painted	96.9	m <sup>2</sup>	\$	29	1.00	1.15	\$	3,179.86	RSMeans 06 16 36.10 0800
Architectural	Dry Well 2nd floor	Interior Wall E - 19 mm GIS Plywood painted	68.0	m <sup>2</sup>	\$	29	1.00	1.15	\$	2,231.48	RSMeans 06 16 36.10 0800
Architectural	Dry Well 2nd floor	Interior Wall N - 19 mm GIS Plywood painted	32.4	m <sup>2</sup>	\$	29	1.00	1.15	\$	1,063.23	RSMeans 06 16 36.10 0800
Architectural	Odour Control	Interior Wall W - 19 mm GIS Plywood painted	68.0	m <sup>2</sup>	\$	29	1.00	1.15	\$	2,231.48	RSMeans 06 16 36.10 0800
Architectural	Odour Control	Interior Wall N - 19 mm GIS Plywood painted	24.0	m <sup>2</sup>	\$	29	1.00	1.15	\$	787.58	RSMeans 06 16 36.10 0800
Architectural	Mechanical	Interior Wall N - 19 mm GIS Plywood painted	48.0	m <sup>2</sup>	\$	29	1.00	1.15	\$	1,575.16	RSMeans 06 16 36.10 0800
Architectural	Mechanical	Interior Wall W - 19 mm GIS Plywood painted	12.0	m <sup>2</sup>	\$	29	1.00	1.15	\$	393.79	RSMeans 06 16 36.10 0800
Architectural	Mechanical	Interior Wall S - 19 mm GIS Plywood painted	48.0	m <sup>2</sup>	\$	29	1.00	1.15	\$	1,575.16	RSMeans 06 16 36.10 0800
Architectural	Electrical	Interior Wall S - 19 mm GIS Plywood painted	48.0	m <sup>2</sup>	\$	29	1.00	1.15	\$	1,575.16	RSMeans 06 16 36.10 0800
Architectural	Electrical	Interior Wall W - 19 mm GIS Plywood painted	64.0	m <sup>2</sup>	\$	29	1.00	1.15	\$	2,100.21	RSMeans 06 16 36.10 0800
Architectural	Access Hallway	Interior Wall Centre - 19 mm GIS Plywood painted	92.2	m <sup>2</sup>	\$	29	1.00	1.15	\$	3,023.98	RSMeans 06 16 36.10 0800
Architectural	Access Hallway	Interior Wall S - 19 mm GIS Plywood painted	33.2	m <sup>2</sup>	\$	29	1.00	1.15	\$	1,089.49	RSMeans 06 16 36.10 0800
Architectural	Access Hallway	Interior Wall N - 19 mm GIS Plywood painted	33.2	m <sup>2</sup>	\$	29	1.00	1.15	\$	1,089.49	RSMeans 06 16 36.10 0800
Architectural	Access Hallway	Interior Wall E - 19 mm GIS Plywood painted	14.0	m <sup>2</sup>	\$	29	1.00	1.15	\$	459.42	RSMeans 06 16 36.10 0800
Architectural	Generator	Interior Wall S - 19 mm GIS Plywood painted	42.5	m <sup>2</sup>	\$	29	1.00	1.15	\$	1,393.49	RSMeans 06 16 36.10 0800
Architectural	Generator	Interior Wall E - 19 mm GIS Plywood painted	32.0	m <sup>2</sup>	\$	29	1.00	1.15	\$	1,050.11	RSMeans 06 16 36.10 0800
Architectural	Washroom	Interior Wall N - 19 mm GIS Plywood painted	24.0	m <sup>2</sup>	\$	29	1.00	1.15	\$	787.58	RSMeans 06 16 36.10 0800
Architectural	Washroom	Interior Wall S - 19 mm GIS Plywood painted	24.0	m <sup>2</sup>	\$	29	1.00	1.15	\$	787.58	RSMeans 06 16 36.10 0800
Architectural	Wet Well	Epoxy Coating inner wall	247.4	m <sup>2</sup>	\$	2	1.15	1.15	\$	490.74	
Architectural	General	Roof Insulation									
Architectural	Drywall 2nd Floor	Glazing		ea							
Architectural	General	Single Doors	7.0	ea							
Architectural	General	Exterior, weather proof Double Doors	1.0	ea	\$	2,070	1.00	1.15	\$	2,380.50	RSMeans 08 11 16.10 0020
Architectural	Odour Control	Exterior, weather proof Double Doors	1.0	ea	\$	2,070	1.00	1.15	\$	2,380.50	RSMeans 08 11 16.10 0020
Architectural	Electrical	Interior double doors to Electrical	1.0	ea							
Architectural	General	Stairs									
Architectural	Dry Well 2nd Floor	Floor Hatch	5.0	ea.							
Electrical	General	All Building Electrical		L.S.	\$	2,254,557	1.00	1.00	\$	2,254,557.25	
Electrical	General	Grounding system		L.S.							
Electrical	General	OFN Conduit from PS to CCWTP	25,000.0	m							
Electrical	General	OFN Cable from PS to CCWTP	25,000.0	m							
General		Commissioning (2%)	0.0	%	\$	13,303,979			\$	266,079.59	
General		Warranty (2%)	0.0	%	\$	13,303,979			\$	266,079.59	
General		Site Office / Admin Costs	180.0	day	\$	800			\$	144,000.00	
General		Insurance & Bond	0.0	%	\$	13,303,979			\$	266,079.59	
General		Mobilization and Demobilization Costs	0.0	%	\$	13,303,979			\$	399,119.38	
						<b>SUB-TOTAL</b>				<b>\$ 14,645,337</b>	
						<b>PST Tax</b>		<b>7%</b>		<b>\$ 1,025,173.62</b>	
								<b>TOTAL</b>		<b>\$ 15,670,511</b>	

DISCIPLINE	EST. COST	
GENERAL	\$1,341,358	
CIVIL-ALIGN	\$6,285,729	
CIVIL-SITE	\$632,489	
STRUCTURAL	\$1,960,953	
ARCHITECTURAL	\$362,689	
PROCESS-MECHANICAL	\$1,383,534	
PLUMBING	\$120,000	
HVAC	\$299,531	
ELECTRICAL	\$2,254,557	
INSTRUMENTATION	\$4,497	
<b>SUB-TOTAL</b>	<b>\$14,645,337</b>	
Class B	15%	\$2,196,800.62
Contingency		
CONST.	10%	\$1,464,534
CONTINGENCY		
<b>TOTAL (INCL. PST)</b>		<b>\$18,306,672</b>



210-889 Harbourside Drive  
North Vancouver BC V7P 3S1  
Canada

t: +1 604 990 4800  
f: +1 604 990 4805  
w: [www.opusinternational.ca](http://www.opusinternational.ca)